

Wallace & Tiernan®

Flow Measurement Equipment

Glass Tube Purge Meters Stainless Steel Frame

Wallace & Tiernan® Purge Meters are low-capacity variable area meters which incorporate several improvements in basic design. They feature an unusually rigid, corrosion resistant stainless steel frame and a positive, easily controlled tube lock.

Purge Meters are specifically designed for such service as the purging of instrument cases and control lines. They are readily adapted to liquid-level indication, sampling, liquid-specific-gravity determination, and similar applications.

Features

Structurally Strong Frame

The side frames are heavy, channel-form stainless steel sections welded to stainless end fittings turned from bar stock. This produces a rigid unit which resists pipe strains and protects tube alignment.

Choice of Corrosion Resistant Materials

The frame is made of 304 stainless steel and the end fittings are made of 316 stainless steel. The metering-tube retainer is Kynar® vinylidene fluoride resin with 316 stainless optional. O-rings come in a choice of Buna N or Viton® with Kalrez® and EPR (ethylene propylene rubber) optional. Valve trim (seat and stem) is 316 stainless.

Positive Tube Lock and a Tube Shield

A knurled tube-locking nut, external to the flow, positions the tube retainer and locks the tube firmly in place. Tube removal is quick and easy. O-rings seal the tube at both ends. A clear plastic shield covers the tube.

Versatile Flow Controller

An optional Flow Controller keeps flow constant regardless of pressure variations. It comes in brass or 316 stainless steel, in inlet or outlet configurations and high or low capacities. Replaceable seat adapters make for easy capacity changes. Straight-through design means the controller can be threaded directly into the meter body, eliminating pipe nipples and static piping.

Key Benefits:

- Rugged Kynar® frame to withstand aggressive environments
- Wide choice of arrangement and operating positions
- Quick and easy removal of tube and float for cleaning or replacement
- Built-in anti-back flow device
- Smooth and fine adjustment of flow with optional control valve.



Glass Tube Purge Meters with Stainless Steel Frame

Product Sheet

Features (Cont'd)

Integral Backcheck

An anti-backflow device is built into the discharge. It consists of a 316 stainless steel poppet with the selected O-ring seal.

High Interchangeability

All parts, except tubes, frames, and plastic shields, are interchangeable regardless of scale length. Tubes have same size o-rings at each end. The tubes for all capacities fit one frame size. This and the one-piece frame make for design simplicity with simplified maintenance and spare parts stocking.

Choice of Arrangements and Operating Position

Purge Meters are available in 1-1/2- and 3-inch scale lengths. They can be supplied with: an integral flow control valve with a screwdriver-slot stem or a knob for adjustment; a factory-connected flow controller to maintain constant flows; and a plastic bezel for flush panel mounting (on the 3-inch size). The meter can be inverted and its tube reversed to change the control valve from the inlet to the discharge.

Versatile Control Valve

The optional control valve has a common stem with high or low capacity seats; all are 316 stainless. An O-ring in the seat makes it easy to change. The valve gives smooth adjustment and a fine degree of control.

Technical Data

Accuracy

10% of full scale.

Operating Range

10 to 1.

Pipe Connections

1/4-inch female NPT at meter inlet and outlet, at control valve inlet, and at flow controller inlet; horizontal in and horizontal out.

Mounting

In-line; wall through mounting holes in the back of the frame; flush panel with optional bezel.

Scales

As indicated in Tables B and C.

Pressure and Temperature Limits

Temperature and pressure are interdependent but these limits must not be exceeded.

Tube Retainer	O-Rings	Pressure (PSIG)	Temperature (°F)
Kynar®	All	200	
316 SS	Buna N	250	200
316 SS	Viton®	250	200
316 SS	EPR	250	250
316 SS	Kalrez®	250	250

See WT.500.001.000.UA.CG for details on fluid compatibility.

Special Calibration

Excluding extra low capacities. Scales calibrated in other than the standard units in Tables B and C and for fluids with viscosity other than 1 centistoke are available at an extra cost.

Materials of Construction

Frame / End Fittings	304 Stainless
Tube	Borosilicate Glass
Float	See Tables B and C
Tube Retainer	Kynar®, 316 Stainless (optional)
Lock Nut	Kynar®
Flow insert	Kynar®
(used with high capacity meters only)	
Tube Shield	Polycarbonate
End Fittings, Check Valve, Pipe Plug, Popper & Valve Trim / Adapter / Retainer	316 Stainless

Shipping Weights

Meter only, 1 lb.; Meter with control valve, 2 lbs.; Panel mounting bezel, 3 lbs.

Accessories

Flow Controllers

Purge Meters with control valves and Wallace & Tiernan® Flow Controllers are designed to give reliable flow control, regardless of pressure changes.

For liquid service, specify inlet type from Selection 5 of the ordering procedure section found on page 4. For gas service with varying upstream and constant downstream pressures, specify inlet type. For gas service with constant upstream and varying downstream pressures, specify outlet type.

Meters with valves at the outlet have a ball check instead of a poppet. See WT.570.100.000.UA.PS for information.



Flush Panel Mounting

Plastic bezels for flush mounting are available at nominal cost. They are easy to keep clean and the meter is readily accessible.

Selection Procedure

Determine the capacity range, temperature and pressure capability, materials of construction, and options required for each meter. See Technical Data Section for pressure and temperature limits.

Note: For fluids with SP.GR. other than 1.0 or viscosity other than 1.0 CSS, consult your local Varea-Meter® System Distributor.

Table A – Ordering Numbers For Basic Meter Arrangements

Capacity	Function	316 Stainless End Fittings	
		Buna N/ Kalrez®/epr O-rings	Viton® O-rings
Extra Low 1.75 ccm H ₂ O or 145 sccm air maximum	Meter Only	20	30
	Meter With Control Valve	Not Available	
Low 5 GPH H ₂ O or 30 scfh air maximum	Meter Only	20	30
	Meter With Control Valve	Valve Trim	316 SS
		With Knob	22
With Slot	26	36	
High 40 GPH H ₂ O or 110 scfh air maximum	Meter Only	20	30
	Meter With Control Valve	Valve Trim	316 SS
		With Knob	24
With Slot	28	38	

Table B – Ordering Numbers For Tubes, Floats and Scales – Water

	Max. Capacity and Scale Units	1½" Scale Length	3" Scale Length	Float Material
Extra Low Capacity	0.32 ccm 0-100%	- -	- C013	Sapphire
	0.34 ccm 0-100%	- C021	- -	Sapphire
	0.65 ccm 0-100%	- -	- C033	316 SS
	0.95 ccm 0-100%	- C041	- -	316 SS
	1.10 ccm 0-100%	- -	- C053	Tantalum
	1.75 ccm 0-100%	- C061	- -	Tantalum
	Low Capacity	0.1 gph 6 ccm 0-100%	- - C071	A073 - C073
0.5 gph 30 ccm 0-100%		A081 - C081	A083 B083 C083	316 SS
1.0 gph 60 ccm 0-100%		A091 B091 C091	A093 B093 C093	Black Glass
3.0 gph 180 ccm 0-100%		A101 B101 C101	A103 B103 C103	316 SS
5.0 gph		A111	A113	Black Glass
8.0 gph 500 ccm 0-100%		A121 B121 C121	A123 B123 C123	316 SS
15.0 gph 900 ccm 0-100%		A131 B131 C131	A133 B133 C133	316 SS
25.0 gph 1500 ccm 0-100%		A141 B141 C141	A143 B143 C143	316 SS
High Capacity	40.0 gph 2500 ccm 0-100%	A151 - C151	A153 B153 C153	Tantalum

Table C – Ordering Numbers For Tubes and Floats – Air

	Max. Capacity And Scale Units	1½" Scale Length	3" Scale Length	Float Material
Extra Low Capacity	30 sccm 0-100%	- -	- D013	Sapphire
	46 sccm 0-100%	- -	- D033	316 SS
	50 sccm 0-100%	- D021	- -	Sapphire
	87 sccm 0-100%	- -	- D053	Tantalum
	105 sccm 0-100%	- D041	- -	316 SS
	145 sccm 0-100%	- D061	- -	Tantalum
	Low Capacity	1.0 scfh 0-100%	E071 D071	E073 D073
2.5 scfh 0-100%		E081 D081	E083 D083	316 SS
6.0 scfh 0-100%		E091 D091	E093 D093	Black Glass
12.0 scfh 0-100%		E101 D101	E103 D103	316 SS
20.0 scfh 0-100%		E121 D121	E123 D123	Black Glass
30.0 scfh*		E111	E113	Black Glass
High Capacity	36.0 scfh 0-100%	- D131	E133 D133	316 SS
	60.0 scfh 0-100%	E141 D141	E143 D143	Black Glass
	110 scfh 0-100%	E151 D151	E153 D153	316 SS

Note: 472 sccm = 1 scfh

Note: For special calibrations of low and high capacity meters, the first digit of the tube, special scale calibration float and scale code is an L for liquid service and a G for gas service.

Warning: Do not use Glass-Tube Meters for fluids which are toxic, hazardous or attack glass.

Ordering Procedure

To order a low capacity purge meter and control valve with knob and 316 stainless trim, specify 22. To order a tube with 3-inch scale, capacity of 30 ccm water, and scale units in ccm add B083. Add S for standard O-ring material, add S for standard Kynar® tube retainer, add X for no flow controller, add 2 for bezel to accommodate meter with control valve, add 2 for control valve at inlet, add X for no tag. Thus the complete ordering number is: **22 B083 S S X 2 2 X.**‡

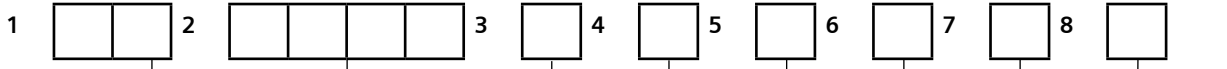

1 - Basic Meter Arrangement

From Table A			
<input type="checkbox"/> 20	<input type="checkbox"/> 26	<input type="checkbox"/> 32	<input type="checkbox"/> 38
<input type="checkbox"/> 22	<input type="checkbox"/> 28	<input type="checkbox"/> 34	
<input type="checkbox"/> 24	<input type="checkbox"/> 30	<input type="checkbox"/> 36	

2 - Tube, Scales and Float

From Table B (water) or C (air)

3 - O-Ring Material

Code	Description
S	Buna N or Viton® (standard - from Table A)
1	EPR (optional)
K	Kalrez® (optional)

4 - Tube Retainer Material

Code	Description
S	Kynar® (standard)
1	316 Stainless Steel (optional)

5 - Flow Controller (optional)

	Capacity	Connection	Model	Code
316 S.S.	30 scfh-5 gph	1/2" NPT inlet	5810	S
	30 scfh-5 gph	1/2" NPT outlet	5820	T
	193 scfh-40 gph	1/2" NPT inlet	5850	U
	193 scfh-40 gph	1/2" NPT outlet	5860	Y
BRASS	30 scfh-5 gph	1/2" NPT inlet	5830	N
	30 scfh-5 gph	1/2" NPT outlet	5840	P
	193 scfh-40 gph	1/2" NPT inlet	5870	Q
	193 scfh-40 gph	1/2" NPT outlet	5880	R
	NONE			X

*Flow controller location must be same as valve location (inlet/outlet).

6 - Bezel (optional)

Code	Description
1	Bezel (without control valve)
2	Bezel (with control valve)
X	None

Note: Available only for 3" Scale Length Meter

7 - Control Valve Location (optional)

Code	Description
X	No Valve
2	Inlet Valve
3	Outlet Valve

8 - ID Tag (optional)

Code	Description
X	None
1	Stainless Steel

‡ Note: Your order number should consist of 12 characters.

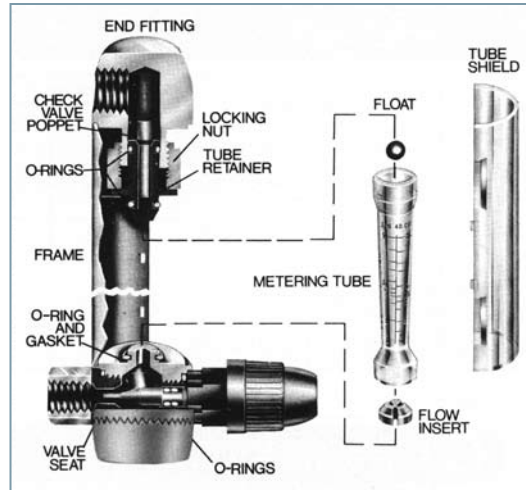

Siemens
Water Technologies

USA
+1 856 507 9000
wtus.water@siemens.com

© 2008 Siemens Water Technologies Corp.
Literature No.: WT.510.100.000.UA.PS.0109
Subject to change without prior notice.

Wallace & Tiernan and Varea-Meter are trademarks of Siemens, its subsidiaries or affiliates. Kynar is a trademark of Arkema Inc. Viton and Kalrez are trademarks of DuPont Performance Elastomers, LLC.

The information provided in this literature contains merely general descriptions or characteristics of performance which in actual case of use do not always apply as described or which may change as a result of further development of the products. An obligation to provide the respective characteristics shall only exist if expressly agreed in the terms of the contract.