

INDUSTRIAL THERMOCOUPLES

A	CODE	HEAD EXTENSION
	1	(NO EXTENSION, 0 "A" LENGTH)
	3	NIPPLE/UNION/ (NOTE 1)

B	CODE	CONNECTION HEAD		
		MATERIAL	TYPE	NEMA
	AN	ALUMINUM	WATER PROOF	4
	SN	STAINLESS STEEL	WATER PROOF, CORROSION RESISTANT	4, 4X
	AE	ALUMINUM	EXPLOSION PROOF (NOTE 2)	4
	SE	STAINLESS STEEL	EXPLOSION PROOF, CORROSION RESISTANT (NOTE 2)	4, 4X
	XD	ALUMINUM	EXPLOSION PROOF, FM, CSA APPROVED (NOTES 2 & 3)	4, 4X
	A	CAST IRON	WEATHER PROOF, RUGGED	
	AX	ALUMINUM, LARGE DEVICE, EPOXY COATED	EXPLOSION PROOF, ATEX APPROVED (NOTE 3)	4

C	CODE	CONDUIT OPENING	D	CODE	TUBE OPENING	E	CODE	"A" LENGTH
		1/2 or 3/4NPT			(NOTE 4)			IN INCHES

F	CODE		ELEMENT CONSTRUCTION			
	SINGLE	DUPLEX	DIAMETER	WIRE SIZE (AWG)	INSULATION	AVAILABLE CALIB.
	B14	BD14	.325"	14	CERAMIC BEAD	K
	B08	BD08	.5"/.69"	8	CERAMIC BEAD	K
	B20	BD20	.125"	20	CERAMIC BEAD	R, S, B
	B22	BD22	.125"	22	CERAMIC BEAD	R, S, B
	B24	BD24	.125"	24	CERAMIC BEAD	R, S, B

G	CODE		CALIBRATION
	STANDARD	SPECIAL (NOTE 5)	
	K	KK	CHROMEL (+) vs ALUMEL (-)
	R	RR	PLATINUM-13%RHODIUM (+) vs PLATINUM (-)
	S	SS	PLATINUM-10%RHODIUM (+) vs PLATINUM (-)
	B	BB	PLATINUM-30%RHOD. (+) vs PLATINUM-6%RHOD (-)

H	CODE		MEASURING JUNCTION
	STANDARD	SPECIAL (NOTE 5)	
	G		SINGLE GROUNDED
	U		SINGLE UNGROUNDED
	DG		DUPLEX GROUNDED
	DU		DUPLEX UNGROUNDED

J	PROTECTION TUBE TYPE					
	CODE	MOUNTING CONNECTION	HEAD CONNECTION	TUBE SIZE I.D.	TUBE SIZE O.D.	MATERIAL
	900	1/2"NPT	1/2"NPT	1/4"	3/8"	MULLITE
	901	3/4"NPT	1/2"NPT	3/8"	1/2"	
	902	1"NPT	3/4"NPT	7/16"	11/16"	
	903	1 1/4"NPT	3/4"NPT	5/8"	7/8"	
	904	1 1/4"NPT	3/4"NPT	3/4"	1"	
	910	1/2"NPT	1/2"NPT	5/32"	1/4"	99.5% PURE ALUMINA
	911	1/2"NPT	1/2"NPT	3/16"	5/16"	
	912	1/2"NPT	1/2"NPT	1/4"	3/8"	
	913	3/4"NPT	1/2"NPT	5/16"	1/2"	
	914	3/4"NPT	1/2"NPT	7/16"	9/16"	
	915	3/4"NPT	1/2"NPT	7/16"	11/16"	
	916	1 1/4"NPT	3/4"NPT	5/8"	7/8"	
	917	1 1/4"NPT	3/4"NPT	3/4"	1"	
	930	NONE	1/2"NPT	5/8"	7/8"	CERMET
	930T	3/4"NPT	1/2"NPT	5/8"	7/8"	

K	PROTECTION TUBE MATERIAL		
	CODE	MATERIAL	MAXIMUM TEMPERATURE
	U	MULLITE (SILICA-ALUMINA)	3,000°F (1,650°C)
	S	99.5% PURE ALUMINA	3,450°F (1,900°C)
	CERMET	METAL-CERAMIC	2,500°F (1,370°C)

L	CODE	"U" LENGTH
		IN INCHES

M	CODE	FLANGE SIZE
		IN INCHES

N	CODE	FLANGE RATING
		SPECIFY

P	CODE		FLANGE TYPE
	FF	RF	
	RF	RJ	
	RJ		
			FLAT FACE
			RAISED FACE
			RING TYPE JOINT

EXAMPLE: 3 AE 3/4 - 3/4 - 3 - BD24 K U - 916 - S - 18 - 1.5 - 300 RF

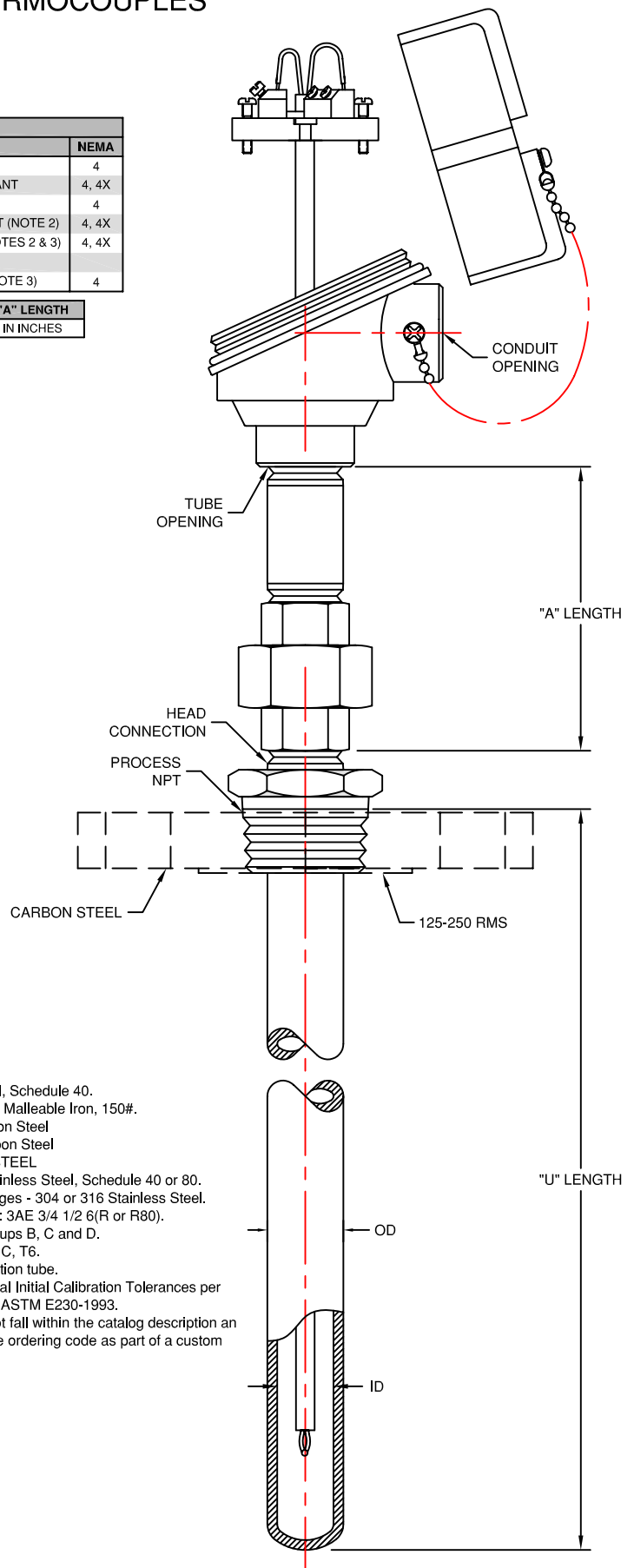
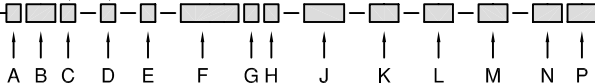

Notes:

- (1) Standard Nipples - Steel, Schedule 40.
Standard Unions - Black Malleable Iron, 150#.
Standard Fittings - Carbon Steel
Standard Flanges - Carbon Steel
- OPTIONAL STAINLESS STEEL
Nipples - 304 or 316 Stainless Steel, Schedule 40 or 80.
Unions, Fittings and flanges - 304 or 316 Stainless Steel.
Example Ordering Code: 3AE 3/4 1/2 6(R or R80).
- (2) Rated NEC class 1, Groups B, C and D.
- (3) ATEX approved EEx d IIC, T6.
- (4) Match opening to protection tube.
- (5) Meets or exceeds Special Initial Calibration Tolerances per ANSI MC96.1-1982 and ASTM E230-1993.
- (6) For an item that does not fall within the catalog description an (SP) can be added to the ordering code as part of a custom construction.



TEMPERATURE MEASUREMENT DESIGNER'S GUIDE
WWW.THERMO-ELECTRIC-DIRECT.COM

SECTION INTC

CERAMIC PROTECTION TUBE ASSEMBLIES THREADED or FLANGED

The information contained hereon shall be considered the sole property of Thermo Electric Company, Inc. The recipient thereof agrees not to disclose or reproduce said information to parties outside the recipient's organization without the written permission of Thermo Electric.

Doc. No.: TE-CO010109-INTC-220