

INDUSTRIAL THERMOCOUPLES

Type A and AD or sheath thermocouple elements are manufactured with CERAMO®, a metal sheath with a hard packed MgO insulation. The sheath material is usually a standard 300 series stainless steel or a nickel base alloy. In most cases the sheath material matches the well material or where the well material is a more special alloy the sheath should match the same temperature rating. Sheath elements are mostly spring loaded by means of a self gripping stainless steel spring which backs up under the terminal block for a constant tip contact inside the well. Insulation resistance (IR) remains high for effective readings at elevated temperatures. Non spring loaded elements terminate with the conductors skinned back from the sheath and the MgO removed for 2 inches. The connection is usually made underneath the block through holes in the ceramic base leading directly to the terminal post. The spring loaded and more common version consists of 3" of stranded and insulated thermocouple lead wire epoxy sealed into the end of the sheath or a transition piece. The leads extend through the hole in the center of the block to the posts. Non spring loaded elements are identified with "+" sticker on the positive leg of the element and the spring loaded by the ANSI color code.

Type B and BD thermocouple elements are the bare thermocouple conductors separated with hard fired ceramic beads. The measuring junction is considered a grounded construction with the tip extending beyond the last bead and fused together. The junction is available ungrounded with the last bead sliced across the holes for a recessed tip or sealed with a high temperature ceramic potting compound. Beaded elements terminated with 2 inches of unbeaded ends and usually connects to the block the same as the non spring loaded type A and AD. The thermocouple conductors are provided in 20 and 14 gauge used with the bar stock wells with the smaller drilled inside diameters. The larger 8 gauge conductors are used in the larger pipe size protection tubes. This type of element can be supplied in one length and reduced for field installation by simply removing beads and cutting the conductors. Beaded elements are not available spring loaded, the polarity is identified with "+" sticker on the positive leg.

Type B and BD element in the noble alloys, R, S & B are available in 20 and the more common 24 gauge and insulated with high purity alumina beads for high temperature service.

Elements may be ordered by measuring the "L" length of the existing element or using the guide below.

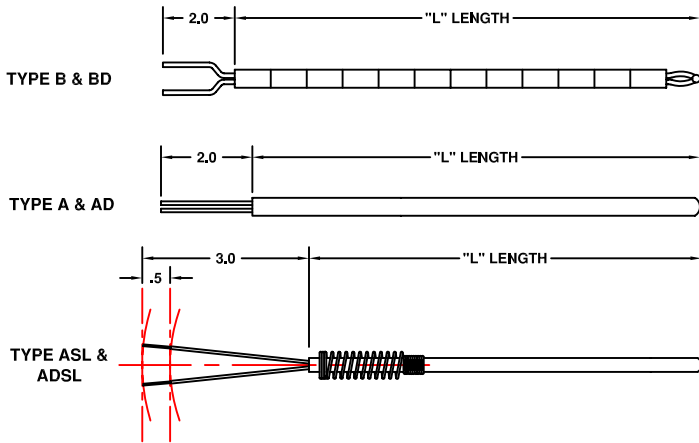
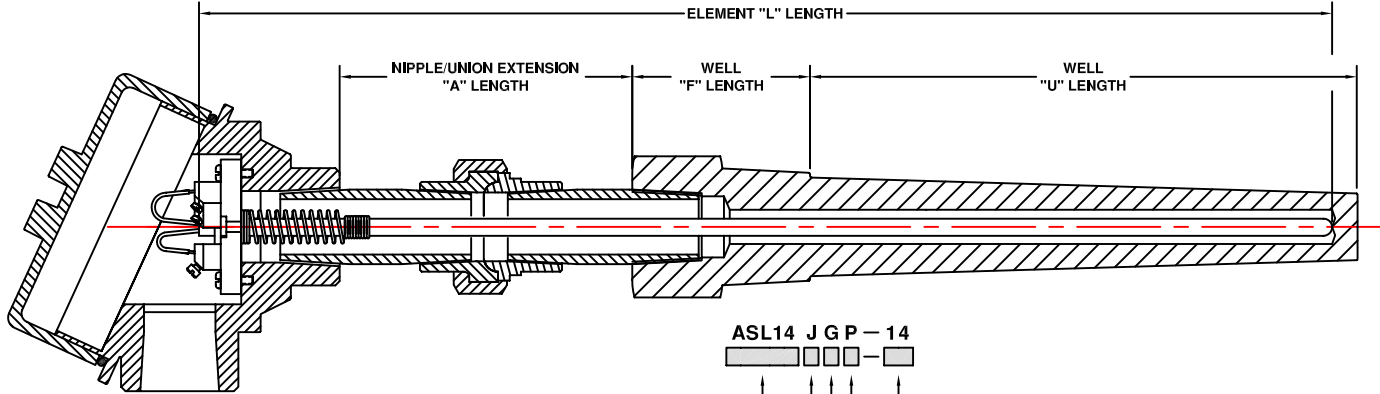

ELEMENT "L" LENGTH EQUALS ASSEMBLY "U" + "F" + "A" + HEAD EXTENSION ADDER BELOW.

CODE	HEAD EXTENSION ADDER		TYPE ASL, ADSL	TYPE B, BD
	MATERIAL			
AN	ALUMINUM		1.5"	0"
SN	STAINLESS STEEL		1.5"	0"
AE	ALUMINUM		1.5"	0"
SE	STAINLESS STEEL		1.5"	0"
XD	ALUMINUM		2.38"	1.0
A	CAST IRON		2.25"	1.0
L	POLYPROPYLENE		2.25"	.5"
AX	ALUMINUM, LARGE DEVICE, EPOXY COATED		2.0"	1.25"

- Notes:
- (1) Meets or exceeds Special Initial Calibration Tolerances per ANSI MC96.1-1982 and ASTM E230-1993
 - (2) KKS & EES denotes stabilized thermocouple and special tolerance.
 - (3) Contact factory for other calibration and sheath combinations.

CODE	"L" LENGTH IN INCHES
P	304 STN. STL.
R	316 STN. STL.
Q	310 STN. STL.
J	INCONEL 600

DROP CODE WHEN USING CERAMIC BEADED ELEMENTS

CODE	MEASURING JUNCTION
G	SINGLE GROUNDED, GROUNDED TO SHEATH
U	SINGLE UNGROUNDED, ISOLATED FROM SHEATH
DG	DUPLEX GROUNDED, GROUNDED TO SHEATH
DU	DUPLEX UNGROUNDED, ISOLATED FROM SHEATH

CODE	CALIBRATION	
	STANDARD	SPECIAL (NOTE 1)
J	JJ	IRON (+) vs CONSTANTAN (-)
K	KK	CHROMEL (+) vs ALUMEL (-)
T	TT	COPPER (+) vs CONSTANTAN (-)
E	EE	CHROMEL (+) vs CONSTANTAN (-)
N	NN	NICROSIL (+) vs NISIL (-)
-	KKS	CHROMEL (+) vs ALUMEL (-) (NOTE 2)
-	EES	CHROMEL (+) vs CONSTANTAN (-) (NOTE 2)

CODE		ELEMENT CONSTRUCTION				
SINGLE	DUPLEX	DIAMETER	WIRE SIZE (AWG)	INSULATION	SPRING LOADED	AVAILABLE CALIBRATION
A316	AD316	3/16"	20	MgO-SHEATH	NO	J, K, T, E, N
ASL316	ADSL316	3/16"	20	MgO-SHEATH	YES	J, K, T, E, N
A14	AD14	1/4"	18	MgO-SHEATH	NO	J, K, T, E, N
ASL14	ADSL14	1/4"	18	MgO-SHEATH	YES	J, K, T, E, N
A516	AD516	5/16"	16	MgO-SHEATH	NO	J, K, T, E, N
ASL516	ADSL516	5/16"	16	MgO-SHEATH	YES	J, K, T, E, N
A38	AD38	3/8"	15	MgO-SHEATH	NO	J, K, T, E, N
ASL38	ADSL38	3/8"	15	MgO-SHEATH	YES	J, K, T, E, N
B20	BD20	.183"	20	CERAMIC BEAD	NO	J, K, T, E, N
B14	BD14	.325"	14	CERAMIC BEAD	NO	J, K, T, E, N
B08	BD08	.687"	08	CERAMIC BEAD	NO	J, K, T, E, N
B20	BD20	.187"	20	ALUMINA BEAD	NO	R, S, B
B24	BD24	.187"	24	ALUMINA BEAD	NO	R, S, B

THERMO ELECTRIC
TEMPERATURE MEASUREMENT DESIGNER'S GUIDE
WWW.THERMO-ELECTRIC-DIRECT.COM

SECTION INTC
REPLACEMENT THERMOCOUPLE ELEMENTS

The information contained hereon shall be considered the sole property of Thermo Electric Company, Inc. The recipient thereof agrees not to disclose or reproduce said information to parties outside the recipient's organization without the written permission of Thermo Electric.

Doc. No.: TE-CO010109-INTC-250