

D-Style Socket Tapered Thermowells

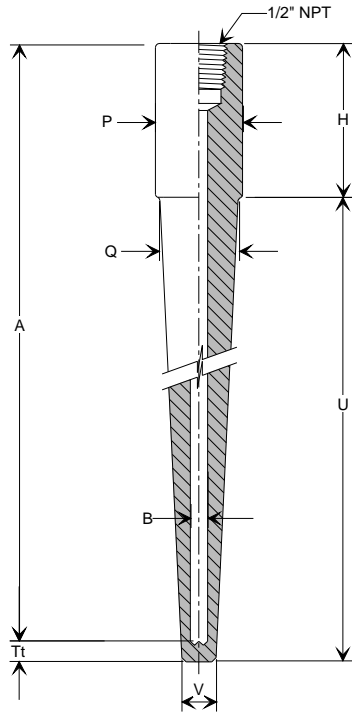

D P H U Tt A M B Q V O

- P - Process Connection**
 34 = 1.050" (26.7), for 3/4" pipe
 10 = 1.315" (33.4), for 1" pipe
 15 = 1.900" (48.3), for 1-1/2" pipe
 Other
- H - Head Length**
 1.750" (44.5), min.
 Other
- U - Insertion Length**
 decimal units
- Tt - Tip Thickness**
 0.250" (6.4)
 Other
- A - Stem Length**
 decimal units
- M - Material**
 refer to table 2.0 on page 23
- B - Bore Size**
 0.260" (6.6)
 0.385" (9.8)
 Other
- Q - Root Diameter**
 refer to table 1.0
- V - Tip Diameter**
 refer to table 1.0
- O - Options**
 refer to page 22

NPS	Rating	Maximum Root Diameter (Q)	Suggested Tip Diameter (V)
3/4"	3000#	0.750" (19.1)	0.625" (15.9)
1"	3000#	1.000" (25.4)	0.750" (19.1)
1-1/2"	3000#	1.500" (38.1)	0.750" (19.1)
3/4"	6000#	See 'E'-Style	See 'E'-Style
1"	6000#	See 'E' or 'F'-Style	See 'E' or 'F'-Style
1-1/2"	6000#	1.250" (31.8)	0.750" (19.1)

Sample Part No.: D10 - 1.750" - 6.000" - 0.250" - 7.500" - R/RL - 0.260" - 0.750" - 0.625" - DR11a, SC3

Notes

1. Contact a sales representative when requiring a thermowell not listed in this catalogue.
2. Metric dimensions are in brackets.