

H-Style Weld-in Straight Thermowells

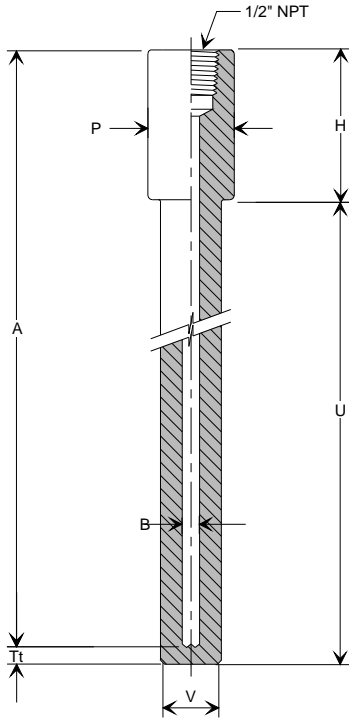

H P H U Tt A M B V O

- P - Process Connection**
Hole size, *min.* 1.000" (25.4) dia.
decimal units
- H - Head Length**
1.750", (44.5), *min.*
Other
- U - Insertion Length**
decimal units
- Tt - Tip Thickness**
0.250", (6.4)
Other
- A - Stem Length**
decimal units
- M - Material**
refer to table 2.0 on page 23
- B - Bore Size**
0.260", (6.6)
0.385", (9.8)
Other
- V - Tip Diameter**
must be less than or equal to 'P'
decimal units
- O - Options**
refer to page 22

Sample Part No.: H1.000" - 1.750" - 6.000" - 0.250" - 7.500" - R/RL - 0.260" - 0.750" - DR11a, SC3

Notes

1. Contact a sales representative when requiring a thermowell not listed in this catalogue.
2. Metric dimensions are in brackets.