

L-Style Flanged Straight Thermowells

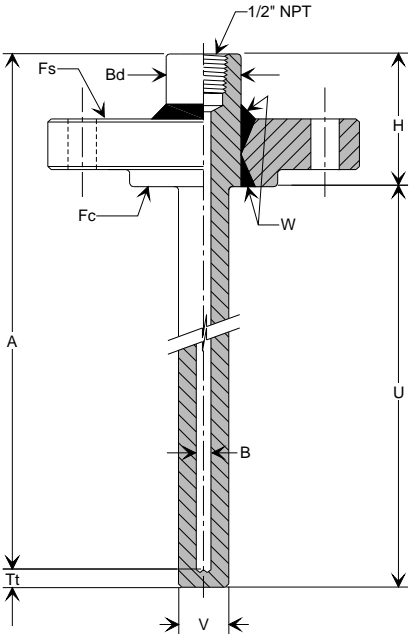

Fs - Flange Size

refer to table 1.6 on page 13

Pr - Flange Rating

150#, 300#, 400#, 600#, 900#, 1500# and 2500#

Fc - Flange Face

RF = Raised Face

FF = Flat Face

RTJ = Ring Type Joint

Fm-Flange Material

refer to table 2.0 on page 23

W - Welding

FP = Full Penetration Weld, refer to figure 1.2 on page 13

PP = Partial Penetration Weld, refer to figure 1.3 on page 13

Bd- Bar Diameter

1.125", (28.6)

1.375", (34.9), see note 1 on page 13

Other

Ps- Schedule Pipe Size

Schedule 40, 80, 160, XXH, refer to table 2.2 on page 27

H - Head Length

refer to table 1.7 on page 13

U - Insertion Length

decimal units

Tt - Tip Thickness

0.250", (6.4)

Other

A - Stem Length

decimal units, see note 1 on page 13

Bm- Bar Material

refer to table 2.0 on page 23

B - Bore Size

0.260", (6.6)

0.385", (9.8)

0.512", (13.0)

0.702", (17.8)

Other

V - Tip Diameter

0.625", (15.9), refer to table 1.8 on page 13

0.750", (19.1), refer to table 1.8 on page 13

1.000", (25.4), refer to table 1.8 on page 13

Other, refer to table 1.8 on page 13

O - Options

refer to page 22

Abbreviation	Flange Size
10	1"
15	1-1/2"
20	2"
25	2-1/2"
30	3"
40	4"

Flange Rating	Flange Size					
	1"	1-1/2"	2"	2-1/2"	3"	4"
150#	2.25" (57.2)	2.25" (57.2)	2.25" (57.2)	2.25" (57.2)	2.25" (57.2)	2.25" (57.2)
300#	2.25" (57.2)	2.25" (57.2)	2.25" (57.2)	2.25" (57.2)	3.25" (82.6)	3.25" (82.6)
400#	2.25" (57.2)	2.25" (57.2)	3.25" (82.6)	3.25" (82.6)	3.25" (82.6)	3.25" (82.6)
600#	2.25" (57.2)	2.25" (57.2)	3.25" (82.6)	3.25" (82.6)	3.25" (82.6)	3.25" (82.6)
900#	3.25" (82.6)	3.25" (82.6)	3.25" (82.6)	3.25" (82.6)	3.25" (82.6)	3.25" (82.6)
1500#	3.25" (82.6)	3.25" (82.6)	3.25" (82.6)	3.25" (82.6)	3.25" (82.6)	3.25" (82.6)
2500#	3.25" (82.6)	3.25" (82.6)	4.25" (108.0)	4.25" (108.0)	4.25" (108.0)	4.25" (108.0)

Flange Size	Pipe Size				Standard Root Radius (rr)
	Schedule 40	Schedule 80	Schedule 160	XXH	
1"	1.000" (25.40)	0.875" (22.23)	0.750" (19.05)	0.500" (12.70)	1/32" (0.79)
1-1/2"	1.298" (32.97)	1.188" (30.18)	1.026" (26.06)	0.788" (20.02)	5/32" (3.97)
2"	1.755" (44.58)	1.627" (41.33)	1.377" (34.98)	1.191" (30.25)	5/32" (3.97)

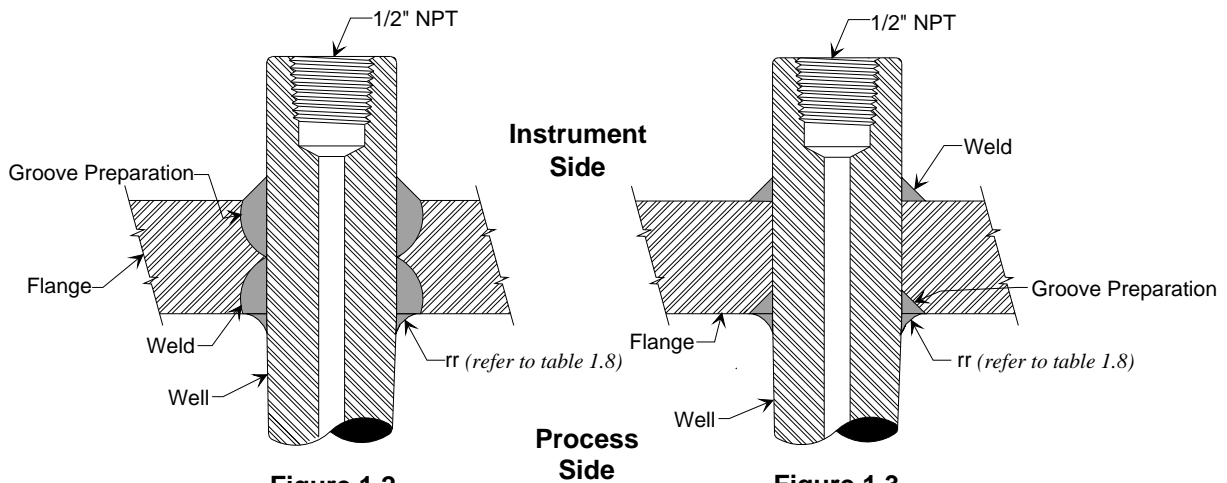

Figure 1.2
Full Penetration Weld
(standard)

Figure 1.3
Partial Penetration Weld

Sample Part No.: L20 - 300# - RF - R/RL - FP - 1.125" - 40 - 2.250" - 6.000" - 0.250" - 8.000" - R/RL - 0.260" - 1.063" - 0.750" - DR11a, SC3
Notes

1. When the Stem Length 'A' is greater than 20" (508) the minimum bar diameter 'Bd' is 1.375" (34.9).
2. Contact a sales representative when requiring a thermowell not listed in this catalogue.
3. Metric dimensions are in brackets.