

## S-Style Wrench Flat Straight Thermowells

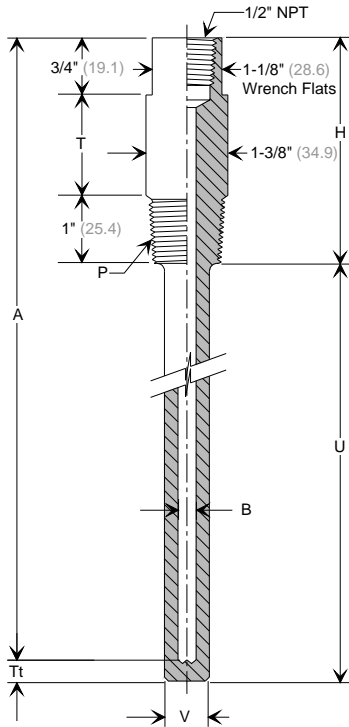

S P H U Tt A T M B V O

**P - Process Connection**

12 = 1/2" NPT, *see note 2*  
 34 = 3/4" NPT  
 10 = 1" NPT  
 Other

**H - Head Length**

1.750" (44.5), for 3/4" & 1" NPT  
 2.000" (50.8), for 1/2" NPT, *see note 2*  
 Other

**U - Insertion Length**

decimal units

**Tt - Tip Thickness**

0.250" (6.4)  
 Other

**A - Stem Length**

decimal units

**T - Lag Length**

decimal units

**M - Material**

*refer to table 2.0 on page 23*

**B - Bore Size**

0.260" (6.6)  
 0.385" (9.8)  
 0.512" (13.0)  
 0.702" (17.8)  
 Other

**V - Tip Diameter**

0.625" (15.9), for 1/2" NPT  
 0.750" (19.1), for 3/4" NPT  
 0.875" (22.2), for 1" NPT  
 Other

**O - Options**

*refer to page 22*

**Sample Part No.:** S34 - 4.000" - 6.000" - 0.250" - 9.750" - 2.250" - R/RL - 0.260" - 0.750" - DR11a, SC3

**Notes**

1. Contact a sales representative when requiring a thermowell not listed in this catalogue.
2. For 1/2" NPT process connection the thread length is 7/8" (22.2) and the overall head length 'H' is 2" (50.8).
3. Metric dimensions are in brackets.