



# RANGER QCT

## ECCENTRIC PLUG ROTARY CONTROL VALVE (ROTARY GLOBE)



4" – Ranger QCT –  
300# Integral Flanged

### APPLICATIONS

The Ranger is a universal control valve that is applicable in most control valve applications, especially steam. It provides longer life on difficult services where conventional ball or globe control valves have problems with body or trim wear. It provides noise control for gaseous service, and cavitation and flashing control for liquid service. It is able to withstand temporary distortions due to "thermal shock" without compromising continued control of the process.

The Ranger QCT is a control valve with a pneumatic spring-diaphragm actuator. It can be supplied with either a flanged or flangeless body style.

This rotary design provides excellent service life in a wide range of applications. Its most unique design feature centers around its Quick Change Trim – QCT. This concept provides front access to the valve body, allowing use of various lo-noise inserts, abrasion sleeve or alternate front-end seal retainers. Also, combinations of these features can be utilized to meet specific application needs.

The Ranger is the most user friendly control valve in the marketplace when it comes to maintenance. It takes a mere five minutes to change trim when out of the pipeline and requires no recalibration.

### FEATURES

The Ranger has many important features that provide users with a cost-effective control valve:

- Seven sizes, 1" – 8" (DN25 – 200)
- ANSI 150/300/600# pressure class capability with **flangeless** body-style \*
- ANSI 150/300/600# pressure class capability for **flanged** body-style in 1"-3" sizes; 150/300# for 4"-8" sizes
- Three body materials
- 21 trim combinations
- Dual seal rings - soft (Class VI) and metal (Class IV)
- Standard live-loaded packing
- Ease of maintenance
- Multiple reduced port configurations
- Cavitation trim
- Lo-noise trim
- Abrasion sleeve
- High capacity
- Integral extended bonnet
- Multi-spring actuator.

\* 8" size only available **flangeless** in ductile iron material.

## PRINCIPAL OF OPERATION

**QCT – Quick Change Trim** is the design concept upon which the Ranger QCT is based. This unique design allows front-access to the body internals. When the plug is in its closed position and the valve is removed from the pipeline, by simply removing the two/four cap screws, immediate access is provided to remove:

- Seal retainer
- Seal retainer gasket
- Soft seal ring
- Metal seal ring.

By inserting a tool into the rear of the body, applying a slight force to the vane of the plug (or lo-noise insert if supplied), and rotating the manual handwheel “down” to remove pre-load and align stem-to-plug joint, the cage can be removed through the body front. This gives access to:

- Plug
- Plug bearings
- Cage
- Lo-noise insert (if supplied).

Reversing the procedure allows trim replacement within five minutes. The valve unit is now ready for reinstallation into the pipeline with no calibration required, as neither the actuator, characterization cam, nor positioner were removed.

QCT provides access to the internals allowing for the use of lo-noise inserts or an abrasion sleeve behind the cage. The concept also allows choosing from multiple seal retainer designs for the front-end. This allows for customization of trim internals to successfully handle se-

vere service applications economically.

The standard flow direction with a Ranger is into the face of the plug's spherical surface. This provides:

- Excellent shut-off capability due to upstream pressure assisting.
- Reduced cavitation and noise levels resulting from maximization of the  $F_L$  factor.

Ranger QCT incorporates a “rigid plug” and a “flexing metal seal ring”.

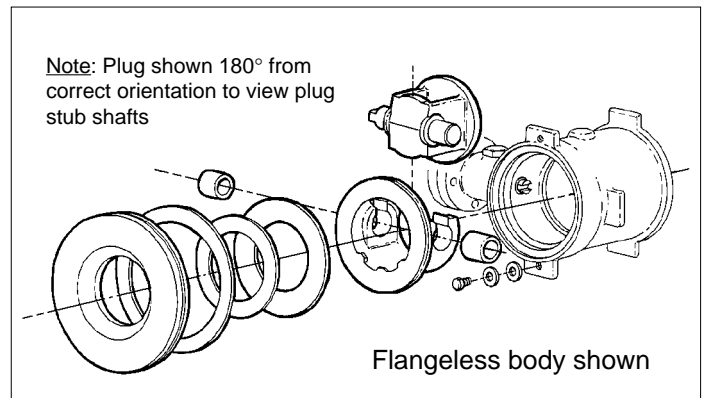

**Stem-to-Plug Connection** – The tongue and groove connection provides as tight a fit as competitive splined designs. A torque-compensating “vane” is integral with the plug to generate uni-directional torque, whether the plug is opening or closing. This design ensures no backlash in the tongue and groove connection during normal throttling.

## STANDARD / GENERAL SPECIFICATIONS

**Body Sizes:** 1", 1-1/2", 2", 3", 4", 6" and 8".  
(DN25, 40, 50, 80, 100, 150, 200.)

**Body Materials:** DI – Ductile Iron.  
CS – Cast Carbon Steel.  
SST – Cast 316 SST.  
See Tables 2A, 2B and 2C for material specifications.

**Body Design Type:** Eccentric plug (rotary globe) with integral extended bonnet.  
Flangeless: Requires use of high strength, extended length line bolting; see Opt-7.  
Flanged: Uses standard flange studs and nuts. (See Fig. 15 for valves with tapped flange bolt holes.)

**Body Pressure/ Temperature Rating:**

TABLE 1

Body End Conn.	Available Body		
	Press. Class	Size	Material
Flangeless	150#/300#	All	DI
	150#/300#/600#	All, except 8" (DN200)	CS, SST
Integral Flanged	150#	All	CS, SST
	300#	All	CS, SST
	* 600#	1", 1-1/2", 2" & 3" (DN25,40,50 & 80)	CS, SST

\* Not available for 4", 6" & 8" (DN 100,150 & 200) body sizes.

See Tables 2A, 2B and 2C for material P vs. T ratings.

**Flange Surface Finish:** 250/125 micro-inch  $R_a$  (equivalent to 250/125 AARH). Suitable for use with spiral-wound metallic gaskets.

**Clamping Companion Flanges:** Not supplied with valve unit. Use only steel or stainless steel piping flanges; socket weld, slip-on, or weld-neck types; RF or FF.

Per ANSI B16.5 Dimensions: All sizes of CS, SST or DI body material; 150# or 300# flange pressure class. All sizes of CS and SST body material; 600# flange pressure class.

Per DIN Dimensions: May be installed between PN40 flanges.

**Body Face-to-Face Dimensions:** Per ISA – S75.04 for flangeless control valves. See Figure 12, dimension “E”. Integral flanged units meet the same dimensions.

**Maximum Body Pressure:** Per ANSI B16.34 and B16.42 (see Tables 2A, 2B and 2C).

Body Material	Max. Pressure @ T = Ambient			
	150# Flgd.	300# Flgd.	600# Flgd.	PN40
DI	250 psig (17.2 Barg)	640 psig (44.1 Barg)	N/A	508 psig (35.0 Barg)
CS	285 psig (19.6 Barg)	740 psig (51.0 Barg)	1480 psig * (102.1 Barg)	580 psig (40.0 Barg)
SST	275 psig (18.9 Barg)	720 psig (49.6 Barg)	1440 psig * (99.3 Barg)	528 psig (36.4 Barg)

\* Not available for 4", 6" & 8" (DN 100, 150 & 200) body sizes with integral flanges.

**Maximum Body Temperature:**

Body Material	Standard Construction
DI	650°F (344°C)
CS or SST	750°F (400°C)

**Maximum Pressure Drop:** See Table 3, Maximum Pressure Drop Capability.

The values in Table 3 apply both to “throttling service” or “shutoff service”.

**Minimum Body Pressure:** Standard Construction:  
P = Ambient ≈ 0 psig (0 Barg).  
Opt -38V Packing @ Vacuum:  
P = Full Vacuum = 0 psia (0 Bara).

**Minimum Body Temperature:** Standard Construction:  
All materials; T = -20°F (-29°C)  
Opt-36 Cryogenic:  
SST body material ONLY;  
T = -325°F (-198°C).

**Flow Direction:** Standard – Into convex face of spherical plug; enters first through seal retainer. Applied in “clean” or noisy

gaseous services, and in “clean” and non-cavitating or non-flashing liquid services.

Reverse – Into back side of plug; exits last through seal retainer. Applied in “unclean”, abrasive, erosive, flashing, or cavitating services.

	Seal Retainer	Back-End Insert	Flow Direction
	Full or Reduced Port	None Abr. Sleeve LN1 – LN4	Both Reverse Std.
	Anti-Cav - AC	None	Reverse
Lo-Noise	LNA, LNB	None LN1 – LN4	Std. Std.
	LNC, LND	None LN1 – LN4	Reverse Std.

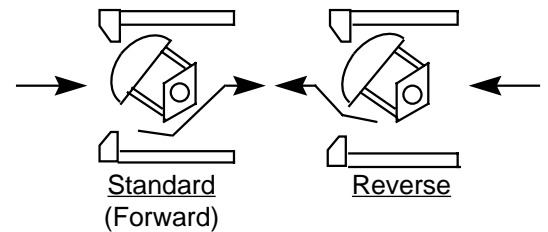

Field reversible sizes 1" through 4" (DN25–100); sizes 6" & 8" (DN150 & 200) require replacement of metal seal ring.

**Inherent Characteristic:**

Linear – Both flow directions, all seal retainers, abrasion sleeve.  
Modified Linear – LN1–LN4 lo-noise inserts.

**Installed Characteristic:**

Without LN1–LN4 lo-noise inserts:  
Linear – Without positioner.  
Equal % or Linear – With characterized cam and positioner.  
With LN1–LN4 lo-noise inserts:  
Modified Linear – Without positioner.  
Modified Equal % or Modified Linear – with characterized cam and positioner.

**Seat Design:**

Standard – Standard flow direction.  
Dual seal rings; composition soft seal with metallic backup seal. Inlet pressure assists sealing.

Optional – Reverse flow direction.  
Inlet pressure does not assist sealing. Only metallic seal effective. Composition seal not available; void may be filled with spacer ring to reduce wear. See Table 4.

**Seat Leakage:**

Per ANSI/FCI 70-2 @  $\Delta P_{min} \geq 50$  psi (3.45 Bar).

**Seat Leakage**  
(Cont.):

Standard – Standard flow direction:  
GF-TFE Soft Seal – Class VI;  
 $-150^{\circ} \leq T \leq 400^{\circ}\text{F}$  ( $-100^{\circ} \leq T \leq 205^{\circ}\text{C}$ )  
TFE-CARB Soft Seal – Class IV,  
approaches Class VI;  $-150^{\circ} \leq T \leq 500^{\circ}\text{F}$  ( $-100^{\circ} \leq T \leq 260^{\circ}\text{C}$ )  
KEL-F Soft Seal – Class VI;  
 $-325^{\circ}\text{F} \leq T \leq 300^{\circ}\text{F}$  ( $-198^{\circ} \leq T \leq 149^{\circ}\text{C}$ )  
Metallic Seal – Class IV;  
 $-325^{\circ} \leq T \leq 750^{\circ}\text{F}$  ( $-198^{\circ} \leq T \leq 400^{\circ}\text{C}$ ).

Optional – Reverse flow direction:  
Metallic Seal – Class IV;  
 $-325^{\circ} \leq T \leq 750^{\circ}\text{F}$  ( $-198^{\circ} \leq T \leq 400^{\circ}\text{C}$ ).

**Rangeability:**

Function of seal retainer and lo-noise trim.

Seal Retainer	Seal Ret. Only	Seal Ret. + LN Insert
Full Port	125:1	80:1
0.6 Reduced Port	75:1	50:1
0.4 Reduced Port	50:1	35:1
0.2 Reduced Port	25:1	15:1
Anti-Cav - AC1,AC2	20:1	N/A
Lo-Noise - LNA,LNC	80:1	30:1
Lo-Noise - LNB,LND	60:1	25:1

**Plug Travel:**

Standard –  $0^{\circ}$ -to- $90^{\circ}$  rotation; rotates CCW-to-open when viewed from actuator end of stem. Handwheel assembly acts as actuator stem “up” travel stop, being able to limit travel from  $0^{\circ}$  –  $90^{\circ}$  Travel stop screw acts as actuator stem “down” travel stop, being able to limit travel approximately  $30^{\circ}$ .

Opt-61 – Special travel stop screw; provides extra  $30^{\circ}$  of travel limitation over standard travel stop screw; i.e.  $60^{\circ}$  total.

**Cv Capacity:**

Function of seal retainer and internal lo-noise trim. See Tables 7 through 10.

Body Size	Max Cv	Max Kv
1" (DN25)	14	12
1-1/2" (DN35)	25	21
2" (DN50)	71	61
3" (DN80)	170	146
4" (DN100)	325	280
6" (DN150)	710	612
8" (DN200)	710	612

NOTE: Cv = 1.16 Kv; Kv is metric flow coefficient.

**Plug Design:**

Eccentric plug action to minimize plug-to-seal ring wear and reduce operating torque.

Patented torque-compensating vane

eliminates plug-to-stem backlash in throttling service by generating uni-directional torque, whether opening or closing.

Standard hard-faced by plating or coating.

**Valve Stem:**

Precision ground and polished. Packing zone critical finish of #8 micro-inch  $R_a$ , or better, to reduce packing maintenance.

Standard square-end design for rapid actuator lever arm removal, and self-jamming connection to eliminate backlash.

Body Size	Stem Diameter
1", 1-1/2" & 2" (DN25, 40, 50)	5/8" (15.9 mm)
3", 4", 6" & 8" (DN80, 100, 150, 200)	1" (25.4 mm)

**Stem Packing:**

Standard: Patented “live-loaded” V-ring packing using Belleville spring washers (see Fig.1); body with integral extended bonnet. Temperature Range  $-325^{\circ} \leq T \leq 750^{\circ}\text{F}$  ( $-198^{\circ} \leq T \leq 400^{\circ}\text{C}$ ), with exposed, uninsulated bonnet above  $400^{\circ}\text{F}$  ( $205^{\circ}\text{C}$ ).

Opt-38 HT: For high temperature service; live-loaded, solid ring packing. Temperature range  $-20^{\circ} \leq T \leq 750^{\circ}\text{F}$  ( $-29^{\circ} \leq T \leq 400^{\circ}\text{C}$ ), with insulated bonnet.

Opt-38V: For continuous vacuum service; same as standard, except V-rings are inverted.

Opt-38J: Similar to standard packing, except no spring washer loading. Conventional adjustment by manually tightening packing follower nuts.

**Bearings:**

Total of five:

- Outboard end-of-stem ball bearing in actuator
- at packing follower
- at the stem retainer
- at upper stub-stem of plug
- at lower stub-stem of plug.

**Gasket:**

Required at seal retainer-to-body joint; controlled compression.

Standard – 316L SST formed chevron cross section, spirally wound type, flexible graphite filled, with alignment/compression control inner ring of 316L SST. Gasket suitable for all steam,

oxygen, and most other services non-corrosive to the 316L SST or graphite (carbon). Temperature Range: -325° to +750°F (-198° to +400°C).

**Painting:** Standard. All non-stainless steel portions of basic unit assembly painted with corrosion resistant epoxy paint per Cashco Spec #S-1606. No paint

on tubing or tube fittings. Accessories – standard paint received from suppliers.

Optional. Two-step, extra thick epoxy coating ; Opt-95.

**Mounting Positions:**

Four for each of ATC-FO Direct or ATO-FC Reverse Action. See Figures 12 and 13.

## BODY SUB-ASSEMBLY MATERIAL SPECIFICATIONS

**Body:** DI – ASTM A395.  
CS – ASTM A216, Gr. WCB.  
SST – ASTM A351, Gr. CF8M.

Trim designation nos. identify:

- metal seal
- soft seal
- spacer
- stem retainer
- stem retainer insert
- plug
- stem
- stem O-ring
- abrasion sleeve.

**Trim:** See Table A below for trim materials determined by body materials or option number.  
See Tables 4 and 4A for trim designation numbers and material specifications.

**TABLE A – PARTIAL TRIM MATERIALS**

Body Size	Option	Body	Port	Seal Retainer	Cage	Plug Bearings
1", 1-1/2", 2", 3" (DN25, 40, 50, 80)	None	DI, CS	All	316 SST	Cast 316 SST	440C
		SST	All	316 SST	Cast 316 SST	Stellite #6B
4" (DN100)		DI, CS	Full	Cast CS	Cast 410 SST	440C
DI, CS		Reduced, AC, LN	Cast 316 SST	Cast 410 SST	440C	
SST		All	Cast 316 SST	Cast 316 SST	Stellite #6B	
6" & 8" (DN150, 200)		DI, CS	Full	Cast CS	Cast 416 SST	440C
DI, CS	Reduced, AC, LN	Cast 316 SST	Cast 416 SST	440C		
SST	All	Cast 316 SST	Cast 316 SST	Stellite #6B		
1", 1-1/2", 2", 3" (DN25, 40, 50, 80)	Opt-40	CS, SST	All	316 SST	Cast 316 SST	Stellite #6B
4", 6", 8" (DN100, 150, 200)		CS	Full	Cast CS		
			Reduced, AC, LN	Cast 316 SST		
	SST	All	Cast 316 SST			

**Plug:** Base material as indicated in Table 4 and footnote.

Hardness - Rc	
Cast 17-4 PH	30–38
Chrome Plate	60–65
Cast Stellite #6B	37–42
ENC - heat treated	66–69

**Stem Sub-Assembly:** As indicated in Table 4. Work-hardened 316 SST pin joining “groove” end to stem for 17-4PH stem; Nitronic 50HS for Nitronic stem.

**Retainer Sleeve Sub-Assembly:** As indicated in Table 4; insert material is non-removeable.

**Stem Retainer Screw:** 316 SST.

**Yoke:** 1", 1-1/2", 2" – CS rectangular steel tubing.  
3", 4", 6", 8" – Ductile iron.

**Yoke Bolting:** 18-8 SST studs, cap screws and nuts.

**Packing Assembly:** Common Parts for “Live-Loading”:  
Retainer & Spacer – 316 SST  
Belleville Spring Washers – SST  
Packing Follower – 18-8 SST  
Packing Flange – 18-8 SST  
Studs, Nuts & Washers – 18-8 SST  
Follower Bushing Bearing – TFE.

**Packing Assembly (Cont.):**  
**Standard:** TFE V-rings and adapters; non-split.  
**Optional:** Flexible graphite die-formed into lower density, interlocking rings, with higher density adapter rings, and top/bottom braided graphite filament rings.

**Soft Seal Ring:**  
 TFE: Glass-filled.  
 TFE: Carbon-filled.  
 Kel-F: Virgin.  
**NOTE:** When soft seal ring is omitted, a fabric reinforced fluorocarbon elastomer "spacer" may be placed into the space of the vacated soft seal ring. (See Table 4.)

**Lo-Noise Inserts:** LN1 – 304 SST; LN2 through LN4 – 316 SST.

**Abrasion Sleeve:** 316 SST.

**Seal Retainer Screws:** 18-8 SST cap screw for all units. 18-8 SST machined washer for "flangeless" body design. 18-8 SST Belleville spring washers for "flanged" body design.

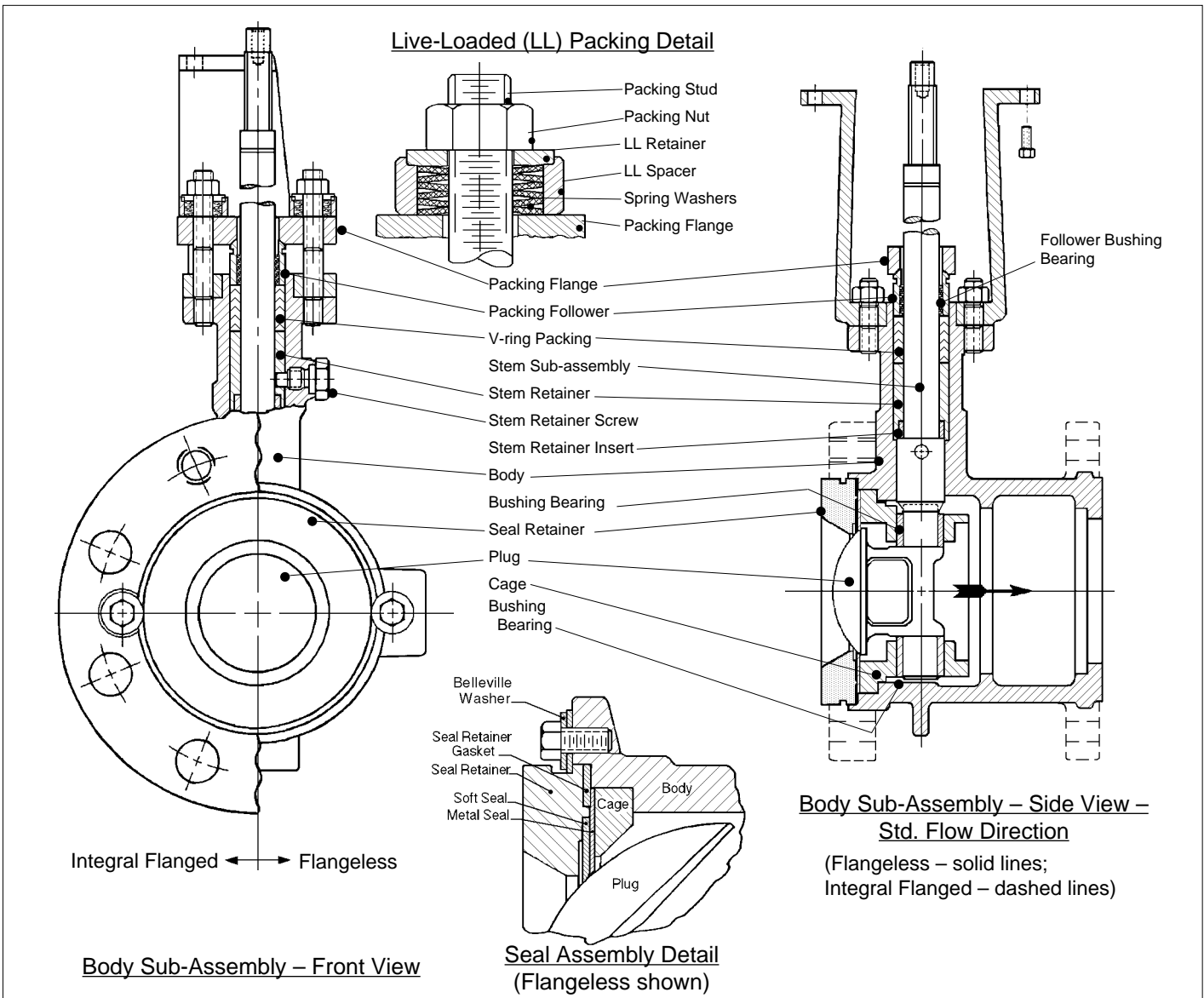

**FIGURE 1:**  
 Ranger Body Sub-Assembly Cutaways

# ACTUATOR TECHNICAL SPECIFICATIONS

**Basic Design:** 0–90° Rotary. Spring-diaphragm type. Rolling diaphragm with multiple springs. Enclosed linkage. Field-reversible for “direct” or “reverse” action (see Figure 2). Standard with manual handwheel operator.

**Stroking Time:** Reference STKSP-TB for stroke times with various accessories.

Action	Model No.	Body Size	Bench Setting Range
Direct; ATC-FO (Increase in air “LOAD” rotates valve stem CW, closing valve)	48D-01	1", 1-1/2", 2" (DN25, 40, 50)	5–15 psig (0.34–1.03 Barg)
	148D-01	3", 4" (DN80, 100)	5–13 psig (0.34–0.90 Barg)
	148D-02	4", 6", 8" (DN100, 150, 200)	10–26 psig (0.69 – 1.79 Barg)
Reverse; ATO-FC (Increase in air “LOAD” rotates valve stem CCW, opening valve)	48R-01	1", 1-1/2", 2" (DN25, 40, 50)	5–15 psig (0.34–1.03 Barg)
	148R-01	3", 4" (DN80, 100)	5–13 psig (0.34–0.90 Barg)
	148R-02	4", 6", 8" (DN100, 150, 200)	10–26 psig (0.69 – 1.79 Barg)

ATC-FO = Air-to-Close, Fail Open;

ATO-FC = Air-to-Open, Fail Close.

**NOTE:** No actuator bench setting range selection required; i.e. one actuator for each body size, *except* 4" size.

**Size, Stroke & Volume:**

Basic Model No.	Nominal Diaphragm Area in <sup>2</sup> (cm <sup>2</sup> )	Lever Arm Length in (mm)	Nominal Stroke * in (mm)	Volumes	
				Clearance in <sup>3</sup> (cm <sup>3</sup> )	Volumetric in <sup>3</sup> (cm <sup>3</sup> )
48D 48R	48in <sup>2</sup> (310)	1.375 (34.9)	1.94 (49.3)	27in <sup>3</sup> (440)	87in <sup>3</sup> (1425)
148D 148R	148in <sup>2</sup> (955)	1.875 (47.6)	2.65 (67.3)	90in <sup>3</sup> (1475)	372in <sup>3</sup> (6095)

\* To generate 90° rotation.

**Maximum Operating Supply Pressure:** 48 D/R = 20 psig (1.38 Barg).  
148 D/R = 36 psig (2.48 Barg).

**Ambient Temperature Range:** -20° ≤ T<sub>amb</sub> ≤ 180°F.  
(-29° ≤ T<sub>amb</sub> ≤ 83°C).

**Mounting Positions:** May be rotated in four - 90° orientations for each “direct” or “reverse” arrangement. See Figures 12 and 13.

**Air Connection:** 1/4" female NPT.

**Travel Stop Screw:** Standard – Limits travel to 0°–90° rotational travel.  
Opt-61 – Allows adjustment of actuator stem “downwards” travel.

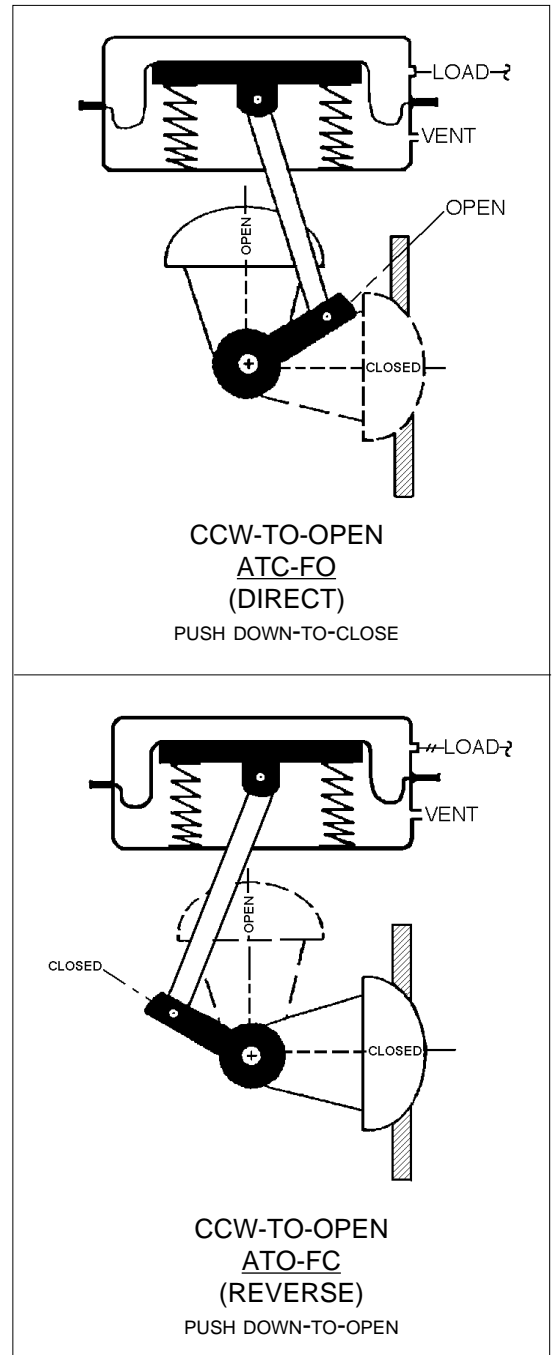

**Figure 2:**  
Plug vs. Lever Arm vs. Actuator Orientation

**NOTE:** To switch “action” requires locating actuator stem to opposite side of valve stem.

## ACTUATOR SUB-ASSEMBLY MATERIAL SPECIFICATIONS

<b>Casings &amp; Diaphragm Plate:</b>	Cast aluminum; ASTM B108, Alloy 319.
<b>Springs:</b>	Epoxy coated steel.
<b>Diaphragm:</b>	Rolling-type; Buna-N with polyester fabric.
<b>Handwheel:</b>	Cast aluminum.
<b>Arm Housing:</b>	Cast iron.
<b>Handwheel Stem:</b>	316 SST.
<b>Handwheel Gland:</b>	Naval brass.
<b>Locking Lever:</b>	Plated malleable iron.
<b>Threadseal:</b>	18-8 SST with Buna-N insert.
<b>Flange Bolting:</b>	18-8 SST.
<b>Turnbuckle Assembly:</b>	Plated steel and SST.
<b>Travel Stop Screw &amp; Jamnut:</b>	Plated steel.
<b>Lever Arms:</b>	SST with SST bolt and nut.
<b>Cam/Spacer:</b>	SST.
<b>Nameplate:</b>	SST.

### Position Indicator Assembly with 9000R P/P Positioner:

Plate – SST with high visibility red indicating zone displaying degree of valve “opening”.  
Housing – 48D/R – aluminum; 148D/R – cast iron.  
Lens – plastic.  
Coverplate – SST.  
External screws – SST.  
Outboard stem bearing – steel ball bearing.

**NOTE:** With 9520R or 9540R, the position indicator is integral with positioner, and housing is cast iron.

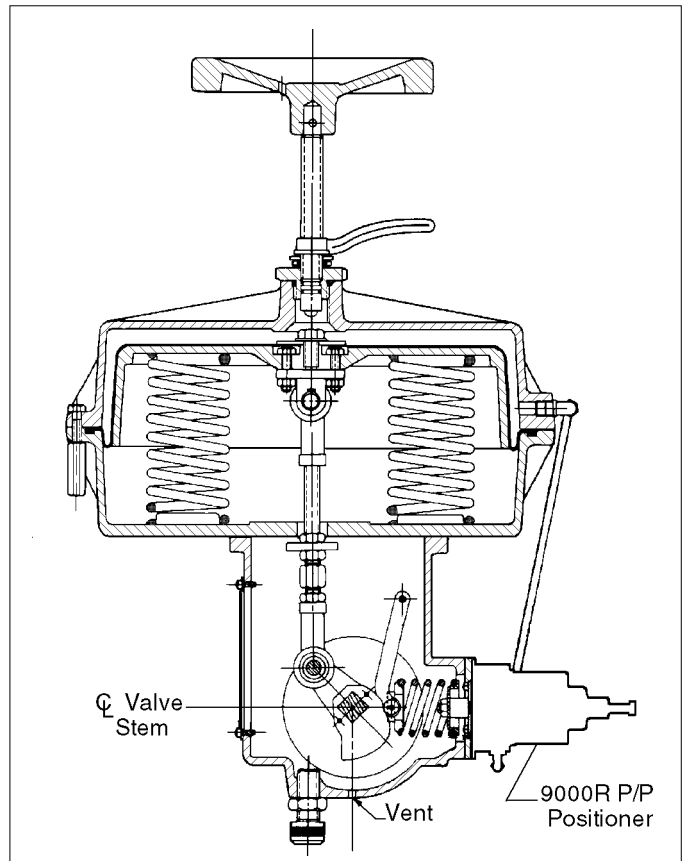

**Figure 3:** Model 148R Actuator with 9000R P/P Positioner with Manual Handwheel Operator

## OPTION SPECIFICATIONS

**Option-3:** NO MANUAL HANDWHEEL OPERATOR. A handwheel and locking lever is supplied as standard for the Ranger. This option covers supplying the unit with NO handwheel operator.

Reverse Action; ATO-FC: Actuator provided with adjusting screw assembly to assist for internal trim removal (see Figure 4).

Direct Action; ATC-FO: Actuator provided with plug in opening upon removal of handwheel assembly (see Figure 4).

**NOTE:** Requires that actuator be pressurized to stroke the plug to near “closed” position, properly orienting tongue and groove connection to allow disengagement for trim removal.

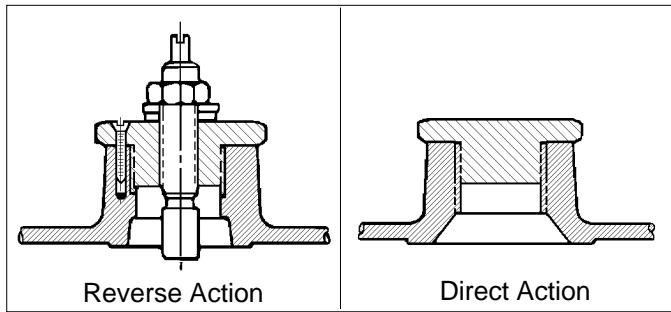

**Figure 4:**

Option-3: No Manual Handwheel Operator - Casing Closure

**Option-7:** LINE BOLTING. For flangeless units only. Extended length, high strength line bolting designed for elongated, eccentric plug, flangeless (wafer) designs. See Figure 14 for required dimensions and installation clearances.

Opt-7A: Heat treated, alloy steel studs per ASTM A193, Gr. B7; carbon steel nuts per ASTM A194, Gr. 2H. Temperature Range:  $-20^{\circ} \leq T \leq 750^{\circ}\text{F}$  ( $-29^{\circ} \leq T \leq 400^{\circ}\text{C}$ ).

Opt-7C: Full cryogenic, corrosion resistant, 18-8 SST (316 SST) strain-hardened studs per ASTM A193, Gr. B8M; 18-8 SST nuts per ASTM A194, GR. 8M.

Temperature Range:  $-325^{\circ} \leq T \leq 750^{\circ}\text{F}$  ( $-198^{\circ} \leq T \leq 400^{\circ}\text{C}$ ).

**Option-18:** SLURRY TRIM. Includes a drilled and tapped (1/8" female NPT, with pipe plug) stem retainer screw to allow purge of neck (bonnet) area of valve body. Fluorocarbon elastomer O-ring impedes ingress of flowing solids into neck zone. Used primarily with saturated solutions that form hard, crusty buildup upon cooling, eventually causing stem "binding". Includes abrasion sleeve with body sizes 1-1/2" – 8". (Selection of Trim Designation No. AT4 includes Opt-18.) Reverse flow direction. See Figure 5. Temperature Range:  $-20^{\circ}\text{F} \leq T \leq 400^{\circ}\text{F}$  ( $-29^{\circ} \leq T \leq 205^{\circ}\text{C}$ ).

**Option-19:** ABRASIVE SERVICE TRIM. Similar to Opt-18, except no purge connection in stem retainer screw.

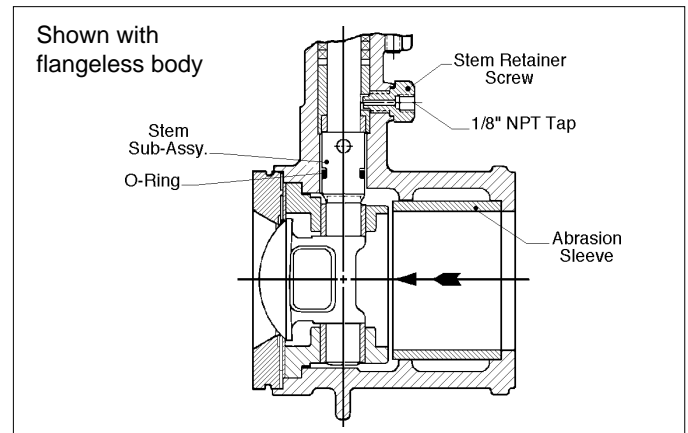

**Figure 5:** Option-18, Slurry Trim

**Option-36:** SST CRYOGENIC. Apply only with SST body material. Includes special cleaning of body per Opt-55. Standard V-ring, live-loaded stem packing. Recommended orientation is with stem vertical in a horizontal pipe. Limited to ANSI 150# or 300# pipe systems.

Temperature Range: Full cryogenic,  $-325^{\circ} \leq T \leq 150^{\circ}\text{F}$  ( $-198^{\circ} \leq T \leq 66^{\circ}\text{C}$ ). Specify Opt-7C line bolting for flangeless designs only.

See Table 4 for recommended trim designation numbers for cryogenic service along with minimum cryogenic temperatures recommended.

**Option-38HT:** HI-TEMP PACKING. Standard TFE V-ring packing is replaced with live-loaded flexible graphite ribbon die-formed into interlocking rings with high density graphite adapters and top/bottom braided graphite filament rings. Primarily recommended for higher temperature service. Use of this optional packing REQUIRES USE OF A VALVE POSITIONER.

**Option-38V:** VACUUM PACKING. Same as standard V-ring packing, except V-rings are inverted (with respect to standard) to seal against air ingress. Orient valve "outlet" to be exposed to the highest vacuum level.

**Option-38J:** JAMMED PACKING. Standard V-ring packing incorporates manually adjustable, conventional packing gland; i.e. non-live loaded.

**Option-40:** NACE SERVICE: Apply only with CS or SST body materials. For sour gas or liquid applications. Specify only trim designation nos. CT1 thru CT5. Meets National Association of Corrosion Engineering (NACE) materials standard #MR0175-90, for exposure of valve internals to fluids with sour gas (H<sub>2</sub>S) present. Requires use of CF8M (cast 316 SST) cage and stellite bearings in CS body sizes 4", 6" and 8" (DN100, 150, 200).  
Temperature range: -20° ≤ T ≤ 400°F (-29° ≤ T ≤ 205°C°).

**Option-55:** SPECIAL CLEANING. Cleaning per Cashco Spec. #S-1134. Only applicable for SST body material. Acceptable cleaning level for oxygen gas service. Use for non-cryogenic, oxygen service.

**Option-56:** SPECIAL CLEANING. Applicable for all body materials. Cleaning per

Cashco Spec. #S-1542. Not suitable for oxygen service.

**Option-61:** TRAVEL-STOP SCREW. Special travel stop screw allows adjustment of actuator stem "downward" travel. For ATO-FC reverse acting actuator units, the "fully open" position may be restricted between 30°–90° travel. For ATC-FO direct acting actuator units, the "fully closed" position may be restricted to 0°–60° travel. Includes jam nut. Screw and jam nut of steel material with zinc plating.

**Option-95:** EPOXY PAINTING. Two-step, extra thick (nominal 4 mil) epoxy coating for severe ambient conditions to minimize external corrosion. Applied to all non-SST exposed parts of basic valve. May be applied to accessories – airset, positioner, transducer, etc., – when specifically requested. Per Cashco Spec #1547.

### "QCT" – RELATED TRIM VARIATIONS

#### Anti-Cavitation Trim:

Anti-cavitation (AC) trim eliminates or reduces the level of cavitation present in liquid service. It locates any cavitation to a point where the valve body and internal trim are spared any damage effects. (Also effective in flashing services.) See Figure 6.

The AC seal retainer design concept utilizes a network of 2-stage orifices to accomplish the following:

- Generate smaller vapor bubbles
- Locate the bubbles near the seal retainer
- Hasten downstream bubble implosion
- Direct flow to downstream pipe center
- Reduce noise
- Reduce vibration
- Reduce downstream pipe wall damage.

The AC seal retainer requires reverse flow direction, thus eliminating ability to incorporate a soft seal ring. Seat leakage is maintained to Class IV or

better. Inherent characteristic remains linear. See Table 3 for pressure drop limitations for AC trim. See Table 9 for flow coefficients.

Two sizes are available; AC1 has higher Cv, and AC2 has fewer orifices and a lower Cv per body size.

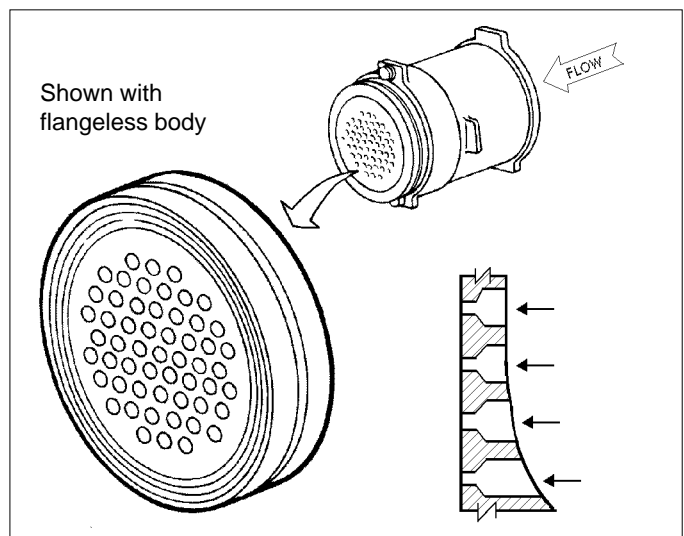

**Figure 6:**  
Anti-Cavitation - AC Trim

**Reduced Orifice Trim:** Three sizes of Reduced Orifice Trims are available for the Ranger QCT – 0.2, 0.4 and 0.6 Cv.

Reduced Orifice Trim is recommended to improve control loop resolution for control valve installations when a line sized valve is more economical than pipe reducers and smaller valves, or when future increases in capacity are planned. See Figure 7.

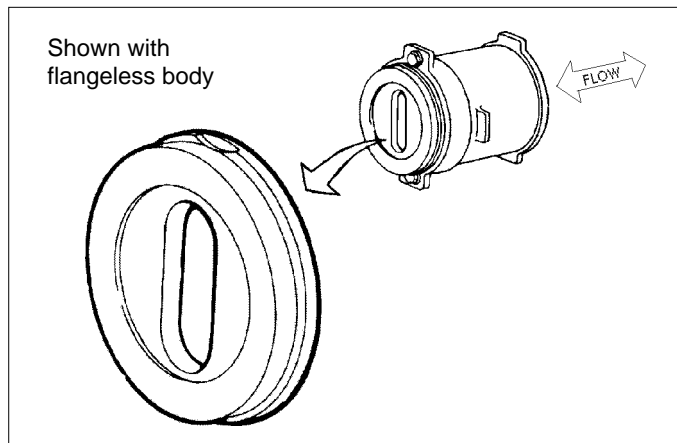

**Figure 7:**  
Reduced Orifice Trim

Reduced Orifice Trims utilize elongated openings to control the maximum Cv while maintaining the linear inherent flow characteristic of the standard trim.

Seat leakage is the same as standard full size trim. Flow direction may be either standard forward or reverse.

**Lo-Noise Trim – LNA/LNB; LNC/LND:** LNA/LNB are similar to the AC1/AC2 seal retainer, except that a soft seal can be installed, flow direction is the standard forward, and the intent is for gas service up to 400°F (205°C) or steam service up to 366°F (186°C). See Figure 8.

LNC/LND are respectively similar to LNA/LNB, except they are for higher temperature services, up to 750°F (400°C), where there is a metal seal only; i.e. no recess in seal retainer for soft seal.

LNB and LND are supplied with fewer orifices than LNA or LNC. See Table 7 for flow coefficients. Inherent character remains linear. Applies to all sizes.

For saturated steam at pressures above 435 psig (30 Barg); because the steam “flashes” upon pressure drop, ONLY LNC or LND should be applied, and in the reverse flow direction only.

LNA through LND are normally applied together with an LN1 through LN4 lo-noise insert; this combination can remove 12–20 dBA of noise.

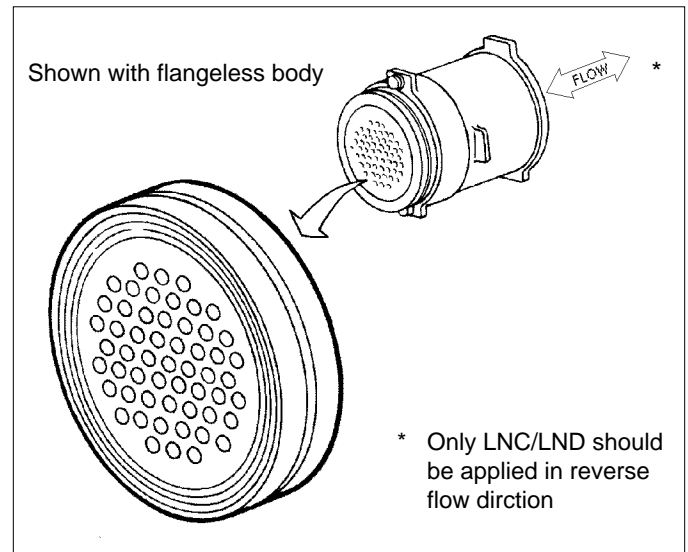

**Figure 8:**  
Lo-Noise Trim – LNA/LNB/LNC/LND

**Lo-Noise Trim – LN1:** For gas or steam service only. Available for 1-1/2"–4" (DN40–100) valves. 7–15 dBA noise attenuation is typical for this insert which is easily installed in the standard body. See Table 10 for flow coefficients. Material is 304 SST. Flow direction is standard forward. See Figure 9.

**Lo-Noise Trim – LN2 thru LN4:** For gas or steam service only. Available for body sizes 1-1/2" – 8" (DN40 – 200) as an insert. Material is 316 SST. Flow direction is standard. See Figure 10.

LN2, LN3 and LN4 are similar except each varies in the number of orifices present. See Table 10 for flow coefficients.

LN2 is available for 1-1/2" – 8" (DN40 – 200) body sizes, and is normally applied together with an LNA through LND seal retainer; this combination can remove 10–16 dBA of noise. This insert may also be supplied with downstream dB plates.

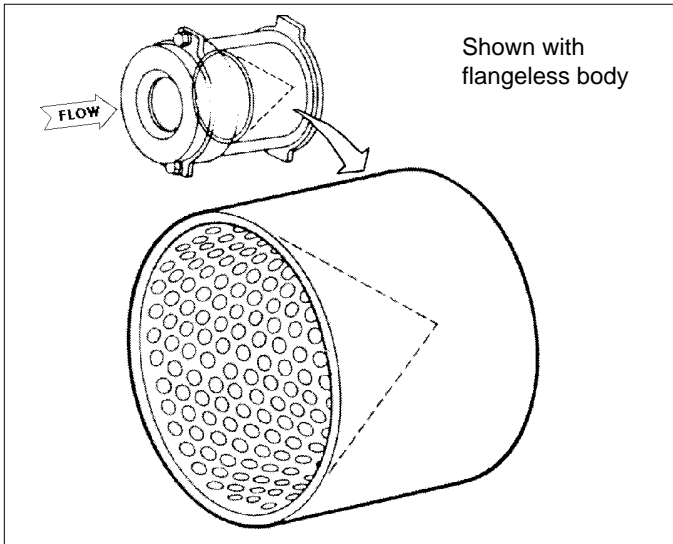

**Figure 9:**  
Lo-Noise Trim – LN1

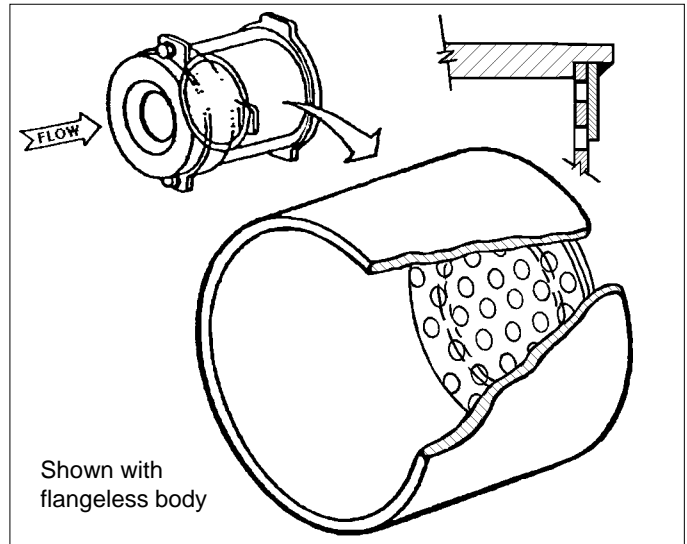

**Figure 10:**  
Lo-Noise Trim – LN2 thru LN4

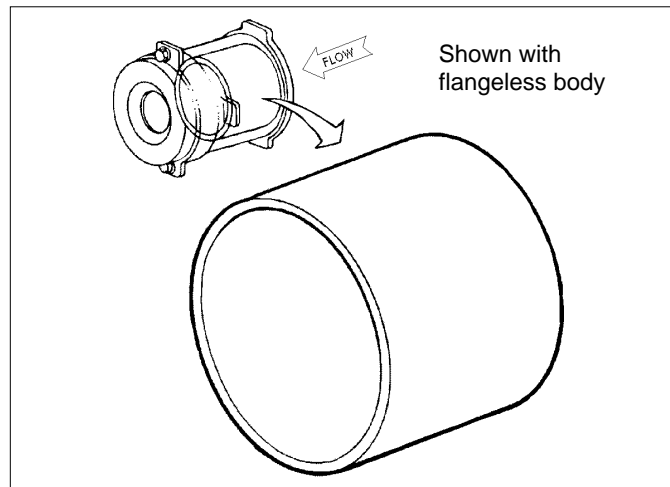

**Figure 11:**  
Abrasion Sleeve

**Lo-Noise Trim – LN2-LN4 (Cont):** LN3 is available for sizes 3" – 8" (DN80 – 200), LN4 is available for sizes 4" – 8" (DN100 – 200). Both are normally applied with downstream dB plates.

Use of LN1 through LN4 lo-noise inserts results in a modified linear inherent characteristic. See Table 10 for flow coefficients.

**Abrasion Sleeve:** The abrasion sleeve (AS) prevents the impingement of solids on the back-end portion of the valve body wall. The standard cage protects the other most vulnerable portion of the valve body. Together these replaceable parts protect the Ranger body from the abrasive action of solids in the flowing fluid.

The abrasion sleeve is also recommended for cryogenic service where the body is exposed to sudden thermal shock; i.e. liquid slug. Flow may be in either direction.

Available in 316 SST for 1-1/2" – 8" (DN40 – 200) valves. Identified as Opt-AS.

The abrasion sleeve can be easily installed in existing valves. Installation has no effect on flow coefficient of basic valve. Recommended to be installed in the reverse flow direction when in abrasive service. See Figure 11.

## APPLICATION AND SELECTION

The following procedure will help determine a suitable selection for an application. Consult your Cashco area representative for assistance in sizing, selection, and noise prediction by computer.

- STEP 1. FIVE KNOWNs.** The following minimal parameters/information must be available before a selection procedure can begin:
- Service Fluid – What is it? Liquid or gas? SG (std. cond.).
  - Inlet Pressure –  $P_1$  (upstream pressure).
  - Outlet Pressure –  $P_2$  (downstream pressure).
  - Desired capacity – Cv, GPM, SCFH; minimum, maximum and normal.
  - Fluid temperature –  $T_1$ , SG (actual).
- Preliminary selections –*  
 2" Ranger with 0.6 reduced port seal retainer:  
 @ Cv = 33 – 78% travel;  
 @ Cv = 13 – 32% travel;  
 Max Cv Available - 42 Cv.  
 2" Ranger with full port seal retainer:  
 @ Cv = 33 – 50% travel;  
 @ Cv = 13 – 21% travel;  
 Max Cv Available = 71 Cv.
- STEP 2. P vs. T BODY RATINGS.** Select a desired body material. For the desired body material assure that the actual design inlet temperature/pressure limits established in Tables 2A, 2B and 2C are not exceeded.
- STEP 3. PRESSURE DROP.** Determine maximum pressure drop under flowing conditions and at shutoff conditions. Do not exceed the limits in Table 3. (**Note:** No actuator selection is required with Ranger QCT as only one size/bench set range exists for each body size, except for the 4" size.)
- STEP 4. CHARACTER and RESERVE.** Decide whether a positioner will be utilized. If an equal % character is desired, a positioner is required. If a linear character is desired, a positioner is not necessarily required as Ranger has an inherent linear characteristic.
- Decide the amount of over-capacity in the selection; i.e. equal % character with 25% reserve capacity. (**Note:** A linear character gives "constant gain" throughout the full travel. An equal % character gives "low gain" up to near 50% of travel, a "medium gain" up to about 75% travel, and a "high gain" the last 25% of travel.)
- STEP 5. CAPACITY.** Using the knowns from Step 1, determine flow direction, and calculate the maximum and minimum Cv required.
- Example:** Max Cv Req'd = 33 Cv;  
 Min Cv Req'd = 13 Cv;  
 Reserve capacity - 20%.
- Max Cv Req'd =  $1.20 \times 33 \text{ Cv} = 39.6 \text{ Cv}$ .
- Select the body size and seal retainer nearest to the 39.6 Cv from Tables 7 or 8.
- STEP 6. RANGEABILITY.** Check the Min. Cv of the selections of Step 5. Always attempt to keep the selection above 10% travel at Min. Cv.
- |                             |               |
|-----------------------------|---------------|
| Full Port – Rangeability    | = 125:1       |
| Min Cv Available            | = 71 Cv / 125 |
|                             | = 0.6 Cv      |
| Reduced Port – Rangeability | = 75:1        |
| Min Cv Available            | = 42 Cv / 75  |
|                             | = 0.6 Cv      |
- Both of the examples of Step 5 are suitable.
- STEP 7. NOISE PREDICTION.** Determine if the predicted noise level exceeds required limits.
- Liquids – the only method to reduce valve noise is to apply AC trim seal retainer, even though the liquid is not experiencing cavitation.
- Gases – multiple choices of LN inserts are available. Choices are also available with LN seal retainers and LN inserts.
- Example:** Assume that example of Step 5 was noisy at 90 dBA. Use of an LN1 insert will normally eliminate 7-15 dBA of noise. Select the body size from Table 10.
- Preliminary selections –**
- 2" Ranger with full port seal retainer and LN1:  
 Max Cv available = 32 Cv.  
 Insufficient Cv; must go to 3" body size.
- 3" Ranger with 0.4 reduced port seal retainer and LN1 insert:  
 Max Cv available = 53 Cv.  
 @ Cv = 33 – 55% travel;  
 @ Cv = 13 – 18% travel.
- 3" Ranger with full port seal retainer and LN1 insert:  
 Max Cv available = 88 Cv.  
 @ Cv = 33 – 25% travel;  
 @ Cv = 13 – 11% travel.

Either selection is acceptable, but the 3" Ranger with 0.4 reduced port and LN1 insert is the better choice.

Rerun noise prediction to determine if new noise prediction is below required limit. Repeat procedure as necessary.

- STEP 8. **FAILURE ACTION.** Consider the process related safety conditions to determine if the valve should "fail open" or "fail close" upon:
- loss of air supply pressure
  - loss of electric power \*
  - loss of both supply air and electric power. \*
- \* Requires 3-way solenoid valve.

STEP 9. **OPTIONAL CONSTRUCTION.** Reference Table 5 and Option Specifications section for recommended options for various fluid services.

STEP 10. **TRIM MATERIALS.** Reference Tables 4 and 5 for selection of the desired Trim Designation Number.

Table 4 indicates the primary service function of each designation; however, the designation numbers may be applied across these groupings; i.e. CY1 (cryogenic trim) can be applied in corrosive chemical service if suitable.

Selection of the designation number also determines the flow direction to be indicated on the body.

STEP 11. **SEAL RETAINER.** Ensure that the proper seal retainer is selected, paying attention to the proper flow direction determined in Step 10.

- STEP 12. **ACCESSORIES.** Consider use of various valve-installed accessories:
- P/P positioner (two choices)
  - I/P positioner (std. & "smart")
  - I/P transducer
  - Position limit switches
  - Position transmitter
  - Solenoid valve
  - Airset(s)
  - 764P/PD pressure controller.

## TECHNICAL SPECIFICATIONS

**TABLE 2A – MATERIAL PRESSURE vs. TEMPERATURE RATINGS**  
**DUCTILE IRON per ANSI B16.42**

Body Material		End Connection	English Units		Metric Units	
General	ASTM Spec. No.		Pressure (psig)	Temperature (°F)	Pressure (Barg)	Temperature (°C)
Cast Ductile Iron (DI)	A395	Flangeless, 150# Flg. * (PN20)	250	-20 to +100	17.2	-29 to +38
			235	200	16.2	94
			215	300	14.8	149
			200	400	13.8	205
			185	450	12.8	233
			170	500	11.8	260
			155	550	10.7	288
			140	600	9.7	316
			125	650	8.6	344
		Flangeless, 300# Flg. (PN50)	640	-20 to +100	44.1	-29 to +38
			600	200	41.4	94
			565	300	39.0	149
			525	400	36.2	205
			510	450	35.2	233
			495	500	34.2	260
			480	550	33.1	288
			465	600	32.1	316
			450	650	31.0	344

\* Based upon CS pipe material.

**TABLE 2B – MATERIAL PRESSURE vs. TEMPERATURE RATINGS**

**CARBON STEEL PER ANSI B16.34**

Body Material		End Connection	English Units		Metric Units	
General	ASTM Spec. No.		Pressure (psig)	Temperature (°F)	Pressure (Barg)	Temperature (°C)
Cast Carbon Steel	A216, GR. WCB	Flanged or Flangeless 150# Flg. (PN20)	285	-20 to +100	19.7	-29 to +38
			260	200	18.0	94
			230	300	15.9	149
			200	400	13.8	205
			185	450	12.8	233
			170	500	11.8	260
			155	550	10.7	288
			125	650	8.6	344
			110	700	7.6	372
		95	750	6.6	400	
		Flanged or Flangeless 300# Flg. (PN50)	740	-20 to +100	51.1	-29 to +38
			675	200	46.6	94
			655	300	45.2	149
			635	400	43.8	205
			615	450	42.4	233
			600	500	41.4	260
			575	550	39.7	288
			535	650	36.9	344
			535	700	36.9	372
		505	750	34.8	400	
		Flanged or Flangeless 600# Flg. (PN100) *	1480	-20 to +100	102.1	-29 to +38
			1350	200	93.1	94
			1315	300	90.7	149
			1270	400	87.6	205
			1235	450	85.2	233
			1200	500	82.8	260
			1145	550	79.0	288
1075	650		74.2	344		
1010	750		69.7	400		

\* Not available for 4", 6" and 8" (DN 100, 150, 200) body sizes with integral flanges. Not available "flangeless" for the 8" (DN200) body size.

**TABLE 2C – MATERIAL PRESSURE vs. TEMPERATURE RATINGS**

**STAINLESS STEEL PER ANSI B16.34**

Body Material		End Connection	English Units		Metric Units	
General	ASTM Spec. No.		Pressure (psig)	Temperature (°F)	Pressure (Barg)	Temperature (°C)
Cast Stainless Steel	A351, Gr. CF8M	Flanged or Flangeless 150# Flg. (PN20)	275 *	-20 to +100	19.0 *	-29 to +38
			235	200	16.2	94
			215	300	14.8	149
			195	400	13.5	205
			180	450	12.4	233
			170	500	11.8	260
			155	550	10.7	288
			125	650	8.6	344
			95	750	6.6	400

\* P<sub>Max</sub> for Cryogenic Opt-36 down to -325°F (-198°C).

**TABLE 2C (Continued) – MATERIAL PRESSURE vs. TEMPERATURE RATINGS**

**STAINLESS STEEL PER ANSI B16.34**

Body Material		End Connction	English Units		Metric Units	
General	ASTM Spec. No.		Pressure (psig)	Temperature (°F)	Pressure (Barg)	Temperature (°C)
Cast Stainless Steel	A351, Gr. CF8M	Flanged or Flangeless 300# Flg. (PN50)	720 *	-20 to +100	50.0 *	-29 to +38
			620	200	42.8	94
			560	300	38.7	149
			515	400	35.6	205
			495	450	34.1	233
			480	500	33.1	260
			465	550	32.1	288
			445	650	30.7	344
			430	700	30.0	372
			425	750	29.3	400
		Flanged or Flangeless 600# Flg. (PN100) **	1440	-20 to +100	99.3	-29 to +38
			1240	200	85.6	94
			1120	300	77.3	149
			1025	400	70.7	205
			990	450	68.3	233
			955	500	65.9	260
			925	550	63.8	288
			890	650	61.4	344
			870	700	60.0	372
			855	750	58.9	400

\* P<sub>Max</sub> for Cryogenic Opt-36 down to -325°F (-198°C).

\*\* Not available for 4", 6" and 8" (DN100, 150, 200) body sizes with integral flanges. Not available "flangeless" for the 8" (DN200) body size.

**TABLE 3 – MAXIMUM PRESSURE DROP CAPABILITY**

Body		Bench Set Range psid (bard)	With Positioner <sup>1</sup>				Without Positioner <sup>2</sup>			With I/P Transducer <sup>3</sup>		
			Trim				Trim			Trim		
Mat'l.	Size		Std psid (bard)	AC * psid (bard)	Std. psid (bard)	Chem ** psid (bard)	Std. psid (bard)	AC * psid (bard)	Chem ** psid (bard)	Std. psid (bard)	AC * psid (bard)	Chem ** psid (bard)
CS or SST	1" (DN25)	5-15 (0.34-1.03)	1400 (96.5)	600 (41.4)	600 (41.4)	700 (48.3)	600 (41.4)	600 (41.4)	600 (41.4)	600 (41.4)	400 (27.6)	400 (27.6)
	1-1/2" (DN40)	5-15 (0.34-1.03)	1200 (82.8)	600 (41.4)	600 (41.4)	600 (41.4)	600 (41.4)	600 (41.4)	600 (41.4)	600 (41.4)	400 (27.6)	400 (27.6)
DI, CS or SST	2" (DN50)	5-15 (0.34-1.03)	600 (41.4)	600 (41.4)	600 (41.4)	300 (20.7)	400 (27.6)	400 (27.6)	300 (20.7)	300 (20.7)	300 (20.7)	200 (13.8)
	3" (DN80)	5-13 (0.34-0.90)	600 (41.4)	600 (41.4)	600 (41.4)	300 (20.7)	600 (41.4)	600 (41.4)	300 (20.7)	400 (27.6)	400 (27.6)	200 (13.8)
	4" (DN100)	5-13 (0.34-0.90)	N/A	N/A	N/A	N/A	200 (13.8)	200 (13.8)	200 (13.8)	150 (10.3)	150 (10.3)	150 (10.3)
		10-26 (0.69-1.79)	600 (41.4)	600 (41.4)	300 (20.7)	200 (13.8)	<b>300 (20.7)</b>	<b>300 (20.7)</b>	<b>150 (10.3)</b>			
	6", 8" (DN150,200)	10-26 (0.69-1.79)	300 (20.7)	300 (20.7)	200 (13.8)	150 (10.3)	<b>200 (13.8)</b>	<b>200 (13.8)</b>	<b>150 (10.3)</b>			
	DI	1", 1-1/2" (DN25, 40)	5-15 (0.34-1.03)	600 (41.4)	600 (41.4)	600 (41.4)	600 (41.4)	600 (41.4)	600 (41.4)	400 (27.6)	400 (27.6)	400 (27.6)
FLOW DIRECTION			Std.	Rev.	Rev.	Both	Both	Rev.	Both	Both	Rev.	Both

<sup>1</sup> Use the "With Positioner" Max ΔP values for use in ON-OFF service.

<sup>2</sup> 3-15 psig (0.21-1.03 Barg) SIG directly to actuator.

<sup>3</sup> 1-17 psig (0.07-1.17 Barg) OUTPUT LOAD directly to actuator (no positioner); 4-20mA INPUT SIG. Tight shutoff may NOT be attained.

\* "AC" = "anti-cavitation" seal retainer.

 With a 3-15 psig (0.21-1.03 Barg) SIG, requires a 1:2 air supply booster.

\*\* "Chem Trim" is defined as any trim that uses a Stellite 6B plug or a Nitronic 50HS Stem; includes trim designation nos. AT2, AT3, AT4, AT5, CT1, CT2, CT3 CT4 and CT5.

**NOTES:** 1. The above pressure drops apply to the valve as a "unit", including all seal retainers and lo-noise inserts.  
2. When "Chem Trim" is applied with an AC seal retainer, the lower of the two "maximum pressure drop" values is to be the upper limit.

**TABLE 4 – TRIM MATERIALS VS. DESIGNATION NOS.**

Part Description	Trim Designation Nos.											
	ST1	ST2	ST3	ST4	ST5	ST6	ST7 **	AT1	AT2	AT3	AT4	AT5
Plug *	Cast 17-4PH	Cast 17-4PH	Cast 17-4PH	Cast 17-4PH	Cast 17-4PH	Cast 17-4PH	Cast Stellite 17-4PH	Cast 17-4PH	Cast Stellite	Cast Stellite	Cast Stellite	Cast Stellite
Stem	17-4PH	17-4PH	17-4PH	17-4PH	17-4PH	17-4PH	17-4PH #6B	17-4PH	17-4PH #6B	17-4PH #6B	17-4PH #6B	17-4PH #6B
Metal Seal Ring	Inconel X-750	Inconel X-750	Inconel X-750	Inconel X-750	Inconel X-750	Inconel X-750	Inconel X-750	Inconel X-750	Inconel X-750	Inconel X-750	Inconel X-750	Inconel X-750
Soft Seal Ring	GF-TFE	None	None	None	None	None	None	TFE + C	None	None	None	None
Spacer	None	None	FR-FKM	FR-FKM	None	None	None	None	FR-FKM	FR-FKM	FR-FKM	FR-FKM
Stem Retainer	316 SST	316 SST	316 SST	316 SST	316 SST	316 SST	316 SST	316 SST	316 SST	316 SST	316 SST	316 SST
Retainer Insert	Carbon	Carbon	Carbon	Carbon	Carbon	Carbon	Carbon	Carbon	Carbon	Carbon	Carbon	Stellite#6B
Abrasion Sleeve	Opt.	Opt.	Opt.	Opt.	Opt.	Opt.	Opt.	Opt.	316 SST	316 SST	Opt.	316 SST
Stem O-ring	Opt.	Opt.	Opt.	Opt.	Opt.	Opt.	Opt.	Opt.	Opt.	Opt.	Opt.	FKM
Flow Direction	Std.	Std.	Std.	Rev.	Rev.	Std.	Std.	Rev.	Rev.	Rev.	Rev.	Rev.
Temperature Range	A	B	C	C	H	E	J	C	C	C	C	G
Primary Service Function	General – Standard - SST							Erosive or Abrasive				
Seal Retainer Groupings	A, B	A,C	A,B	A	A,AC	A,C	A,B	A	A	A	A	A, AC
Insert Groupings	1, 2, AS	1, 2, AS	1, 2, AS	AS	AS	1, 2, AS	1,2,AS	Includes AS	Includes AS	AS	Includes AS	AS
Option Groupings	36		–	18, 19	18, 19	36	36	18, 19			Includes 18	18, 19

Part Description	Trim Designation Nos.									
	CT1	CT2	CT3	CT4	CT5	CY1	CY2	CY3	CY4	
Plug *	Cast Stellite #6B	Cast Stellite #6B	Cast Stellite #6B	Cast Stellite #6B	Cast Stellite #6B	Cast 17-4PH	Cast 17-4PH	Cast 17-4PH	Cast 17-4PH	Cast 17-4PH
Stem	Nitronics 50HS	Nitronics 50HS	Nitronics 50HS	Nitronics 50HS	Nitronics 50HS	17-4PH	17-4PH	17-4PH	17-4PH	17-4PH
Metal Seal Ring	Inconel 625	Inconel X-750	Inconel 625	Inconel X-750	Inconel 625	Inconel X-750	Inconel X-750	Inconel X-750	Inconel X-750	Inconel X-750
Soft Seal Ring	GF-TFE	GF-TFE	None	None	None	Kel-F	Kel-F	None	None	GF-TFE
Spacer	None	None	None	None	FR-FKM	None	None	None	None	None
Stem Retainer	316 SST	316 SST	316 SST	316 SST	316 SST	316 SST	316 SST	316 SST	316 SST	316 SST
Retainer Insert	Carbon	Carbon	Carbon	Carbon	Carbon	Carbon	Carbon	Carbon	Carbon	Carbon
Abrasion Sleeve	Opt.	Opt.	Opt.	Opt.	Opt.	Opt.	Opt.	Opt.	Opt.	Opt.
Stem O-ring	Opt.	Opt.	Opt.	Opt.	Opt.	None	TFE	TFE	TFE	TFE
Flow Direction	Std.	Std.	Rev.	Rev.	Rev.	Std.	Std.	Rev.	Std.	Std.
Temperature Range	A	A	G	G	C	D	D	F	A	A
Primary Service Function	Corrosive – Chemical					Cryogenic				
Seal Retainer Groupings	A, B	A, B	A, AC	A, AC	A	A √	A √	A, AC	A √	A √
Insert Groupings	2, AS	2, AS	AS	AS	AS	AS	AS	AS	AS	AS
Option Groupings	36, 40		18, 19, 36, 40, A, B		18, 19, 40, A, B	36				

“C” = Carbon filled  
 “FKM” = Fluorocarbon elastomer  
 “FR-FKM” = Fabric reinforced fluorocarbon elastomer  
 “GF” = Glass filled  
 Opt. = Optional

\* Cast 17-4PH Plugs are hard chrome plated; cast stellite plugs are electroless nickel coated.  
 \*\* Class IV seat leakage guaranteed; approaches Class VI. Can not be factory tested to Class VI due to low ambient temperature at testing.  
 √ Consult factory for cryogenic applications that are noisy.

KEY	Seal Retainer Grouping
A	Full, 0.6, 0.4, 0.2
B	LNA, LNB
C	LNC, LND
AC	AC1, AC2

KEY	Inserts
1	LN1 *
2	LN2, LN3, LN4 *
AS	Abrasion Sleeve *

\* Not available for 1" Body Size

KEY	Option Groupings
18	-18 Slurry Trim
19	-19 Abrasion Trim
36	-36 Cryogenic
40	-40 NACE
A	-18 + 40
B	-19 + 40

KEY	Temperature Range	
	°F	°C
A	-150 to +400	(-100 to +205)
B	-325 to +750	(-198 to +400)
C	-20 to +400	(-29 to +205)
D	-325 to +400	(-198 to +205)
E	-150 to +750	(-100 to +400)
F	-325 to -20	(-198 to -29)
G	-150 to -20	(-100 to -29)
	400 to 750	(205 to 400)
H	-325 to -20	(-198 to -29)
	400 to 750	(205 to 400)
J	-150 to +500	(-100 to +260)

**TABLE 4A  
MATERIAL SPECIFICATIONS**

Description	Form	ASTM NO. (AMS No.)	UNS No.	Heat Treat- Misc.	Hardness Rockwell
316 SST	Wrought Bar	A479, Gr 316	S31600	Annealed	B88
Cast 316 SST	Cast	A351, Gr CF8M	J92900	Annealed	B85
Cast 416 SST	Cast	(AMS 5349)	J91161	Annealed	B82
Cast 17-4 PH	Cast	A747, Gr CB7-Cu-1	J92180	Cond. H1100	C35-38
17-4 PH	Wrought Bar	A564	S17400	Cond. H 1075	C35
Inconel X-750	Sheet	(AMS 5542)	N07750	Annealed	C35
Inconel 625	Sheet	B443, Gr 625	N06625	Annealed	B88
Nitronics 50	Wrought Bar	A479, Gr XM-19	S20910	Cond. HS	C35
Stellite #6B	Cast	(AMS 5387)	R30006	Heat Treated	C40-42
440C SST	Wrought Bar	A276	S44004	Tempered	C55-60

**TABLE 5  
APPLICATION RECOMMENDATIONS**

Fluid	Recommended Options	Trim Designation Nos.
Air or Industrial Gases (Except O2)	None	ST1, ST2, ST3
Oxygen	Opt-55	ST1, ST2, ST3
Liquids; Clean, Non-Cavitating, Non-Flashing	None	ST1, ST2, ST3
Gas – Clean	None	ST1, ST2, ST3
Steam – Saturated & 150 psig (10.3 Barg) or less	None	ST1, ST2, CT2
Steam – Saturated, 150–400 psig (10.3–27.6 Barg)	None	ST2, ST6
Steam – Superheated	Opt-38HT	ST2, ST6
Hydrocarbon Gas or Liquids	Opt-38HT	ST1, ST2, ST3, ST6, CT1, CT2
NACE – Hydrocarbon Gas or Liquid	Opt-40	CT1, CT2, CT3, CT4, CT5
High Temperature Liquids and Gases	Opt-38HT	ST2, ST6, AT5
Liquids; Clean, Cavitating, Flashing	Use AC Seal Retainer	ST5, AT5, CT3, CT4
Liquids; Slurry, Abrasive	Opt-18, Opt-19	AT1, AT2, AT3, AT4, AT5, ST4, ST5
Cryogenic Liquids; Cavitating, Flashing	Opt-36	CY3, ST5, AT5
Cryogenic Gases	Opt-36	CY1, CY2, CY4, ST1
Non-Corrosive Chemicals	None	ST1, ST2, ST3
Corrosive Chemicals	None	CT1, CT2, CT3, CT4, CT5

**TABLE 6  
MAXIMUM CAPACITY - Cv (kv) \*  
FOR SIZING SAFETY RELIEF DEVICE  
(With Plug @ Approximately 100° Rotation)**

Body Size		Port Size			Port Size			Port Size		
inch	(mm)	Description	Cv	(kv)	Description	Cv	(kv)	Description	Cv	(kv)
1"	(DN25)	Full	16	(14)	0.4 Reduced	6.0	(5.2)	AC1, LNA, LNC	7.9	(6.8)
		0.6 Reduced	10	(8.7)	0.2 Reduced	3.4	(3.0)	AC2, LNB, LND	4.9	(4.2)
1-1/2"	(DN40)	Full	28	(24)	0.4 Reduced	14	(12)	AC1, LNA, LNC	17	(15)
		0.6 Reduced	19	(16)	0.2 Reduced	5.7	(4.9)	AC2, LNB, LND	9.4	(8.1)
2"	(DN50)	Full	78	(67)	0.4 Reduced	32	(28)	AC1, LNA, LNC	32	(28)
		0.6 Reduced	46	(40)	0.2 Reduced	16	(14)	AC2, LNB, LND	18	(16)
3"	(DN80)	Full	187	(161)	0.4 Reduced	73	(63)	AC1, LNA, LNC	63	(54)
		0.6 Reduced	107	(92)	0.2 Reduced	36	(31)	AC2, LNB, LND	35	(30)
4"	(DN100)	Full	357	(308)	0.4 Reduced	137	(118)	AC1, LNA, LNC	120	(104)
		0.6 Reduced	215	(185)	0.2 Reduced	71	(61)	AC2, LNB, LND	68	(59)
6"	(DN150)	Full	830	(715)	0.4 Reduced	341	(294)	AC1, LNA, LNC	220	(190)
		0.6 Reduced	535	(461)	0.2 Reduced	160	(138)	AC2, LNB, LND	123	(106)
8"	(DN200)	Full	785	(677)	0.4 Reduced	341	(294)	AC1, LNA, LNC	220	(190)
		0.6 Reduced	535	(461)	0.2 Reduced	160	(138)	AC2, LNB, LND	123	(106)

\* Values indicated are for non-erosive and/or non-corrosive fluid conditions; user must use own safety factors for these severe conditions.

**TABLE 7**  
**FLOW COEFFICIENTS  $C_v$  – STANDARD TRIM**  
**FORWARD FLOW DIRECTION**

Valve Size	Port	Percent of Plug Open										
		Min.	10%	20%	30%	40%	50%	60%	70%	80%	90%	100%
1" (DN25)	Full Port	0.1	0.8	2.1	3.8	5.5	7.1	8.8	10.1	11.4	12.7	14.0
	0.6 Cv Reduced Port	0.1	0.8	1.8	2.7	3.5	4.6	5.6	6.8	8.0	8.8	9.1
	0.4 Cv Reduced Port	0.1	0.8	1.8	2.7	3.4	4.0	4.4	4.8	5.1	5.4	5.5
	0.2 Cv Reduced Port	0.1	0.4	1.2	1.8	2.2	2.5	2.7	2.9	3.0	3.1	3.1
	LNA or LNC	0.1	0.7	1.8	2.9	3.7	4.6	5.1	6.1	6.7	7.0	7.2
LNB or LND	0.1	0.4	1.1	1.7	2.3	2.8	3.1	3.7	4.1	4.3	4.4	
1-1/2" (DN40)	Full Port	0.2	1.7	4.1	7.1	10.3	13.5	16.8	20.3	22.4	23.7	25.0
	0.6 Cv Reduced Port	0.2	1.7	4.2	6.7	9.0	10.9	12.6	14.2	15.2	16.1	16.8
	0.4 Cv Reduced Port	0.2	1.7	3.8	6.2	8.0	9.4	10.4	11.1	11.6	12.0	12.4
	0.2 Cv Reduced Port	0.2	1.7	3.3	4.1	4.5	4.7	4.8	4.9	5.0	5.1	5.2
	LNA or LNC	0.2	1.1	3.2	5.5	7.7	9.7	11.8	13.4	14.4	15.1	15.2
LNB or LND	0.2	0.6	1.8	3.1	4.3	5.5	6.6	7.5	8.1	8.5	8.5	
2" (DN50)	Full Port	0.6	6	12	20	27	33	40	45	53	62	71
	0.6 Cv Reduced Port	0.6	3.3	8	12	17	21	25	29	34	38	42
	0.4 Cv Reduced Port	0.6	4.4	7.8	12	15	17	20	23	25	27	29
	0.2 Cv Reduced Port	0.6	3.2	5.5	7.2	9	10	11	12	13	14	14.4
	LNA or LNC	0.6	4.4	8.1	11.4	15.2	18.1	20.9	23.8	26	28	29
LNB or LND	0.6	2.5	4.6	6.4	8.6	10.2	11.8	13.4	14.5	15.5	16.1	
3" (DN80)	Full Port	1.4	13	28	43	60	75	90	105	122	144	170
	0.6 Cv Reduced Port	1.4	9	18	29	38	46	56	67	78	88	97
	0.4 Cv Reduced Port	1.4	9	18	26	31	37	42	49	55	61	66
	0.2 Cv Reduced Port	1.4	6.5	12	16	19	23	26	28	30	32	33
	LNA or LNC	1.4	10	17	24	30	36	42	48	52	55	57
LNB or LND	1.4	5.9	9.6	13	17	20	24	27	29	31	32	
4" (DN100)	Full Port	2.6	28	57	88	112	136	162	187	218	265	325
	0.6 Cv Reduced Port	2.6	16	31	51	70	95	110	129	152	173	195
	0.4 Cv Reduced Port	2.6	12	26	40	52	63	75	88	104	117	124
	0.2 Cv Reduced Port	2.6	10	20	28	35	40	45	51	57	61	64
	LNA or LNC	2.6	18	29	41	55	66	77	88	97	104	109
LNB or LND	2.6	10	17	23	31	37	43	50	55	58	62	
6" & 8" (DN150, & 200)	Full Port	5.7	35	90	150	215	290	350	420	497	620	710
	0.6 Cv Reduced Port	5.7	33	68	108	151	192	239	299	368	438	486
	0.4 Cv Reduced Port	5.7	28	56	87	119	143	165	202	236	279	310
	0.2 Cv Reduced Port	5.7	16	32	48	66	78	93	109	125	138	145
	LNA or LNC	5.7	29	52	74	98	120	143	165	183	194	200
LNB or LND	5.7	16	29	41	55	67	80	93	103	108	112	

NOTE: See Graph No. 1 for corresponding  $F_L$  factors.

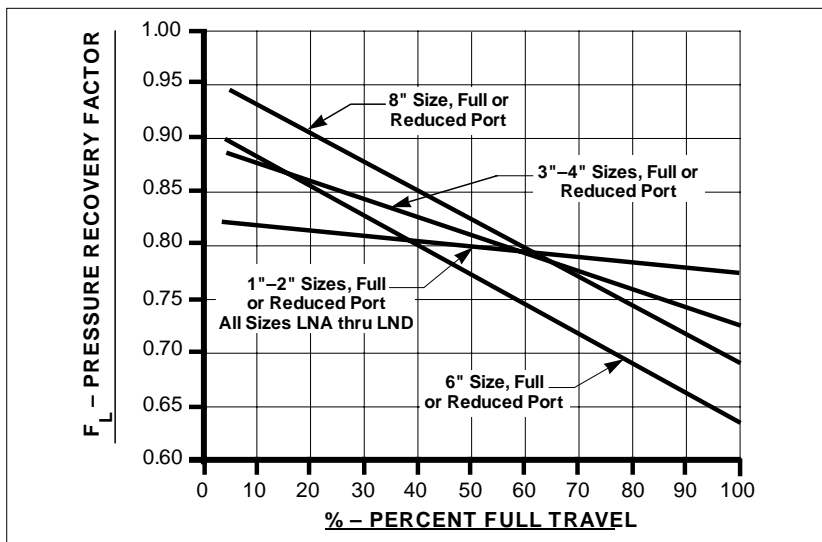

Graph No. 1

@Q @CV

**TABLE 8**  
**FLOW COEFFICIENTS  $C_v$  – STANDARD TRIM**  
**REVERSE FLOW DIRECTION**

Valve Size	Port	Percent of Plug Open										
		Min.	10%	20%	30%	40%	50%	60%	70%	80%	90%	100%
1" (DN25)	Full Port	0.1	1.4	2.8	4.2	5.6	7.0	8.4	9.8	11.2	12.6	14.0
	0.6 Cv Reduced Port	0.1	1.1	1.8	2.7	3.6	4.6	5.5	6.4	7.3	8.2	9.1
	0.4 Cv Reduced Port	0.1	.8	1.1	1.7	2.2	2.8	3.3	3.9	4.4	5.0	5.5
	0.2 Cv Reduced Port	0.1	.6	.6	.9	1.2	1.6	1.9	2.2	2.5	2.8	3.1
1-1/2" (DN40)	Full Port	0.2	2.5	5.0	7.5	10.0	12.5	15.0	17.5	20.0	22.5	25.0
	0.6 Cv Reduced Port	0.2	2.0	3.4	5.0	6.7	8.4	10.1	11.8	13.4	15.1	16.8
	0.4 Cv Reduced Port	0.2	1.9	2.5	3.7	5.0	6.2	7.4	8.7	9.9	11.2	12.4
	0.2 Cv Reduced Port	0.2	.9	1.0	1.6	2.1	2.6	3.1	3.6	4.2	4.7	5.2
2" (DN50)	Full Port	0.6	7.1	14	21	28	36	43	50	57	64	71
	0.6 Cv Reduced Port	0.6	5.0	8.4	13	17	21	25	29	34	38	42
	0.4 Cv Reduced Port	0.6	4.4	5.8	8.7	12	15	17	20	23	26	29
	0.2 Cv Reduced Port	0.6	2.5	2.8	4.2	5.6	7.0	8.4	9.8	11.2	12.6	14.0
3" (DN80)	Full Port	1.3	14	30	45	62	77	91	105	121	142	166
	0.6 Cv Reduced Port	1.3	10	19	30	39	47	57	67	78	87	97
	0.4 Cv Reduced Port	1.3	10	19	27	32	38	43	49	55	60	66
	0.2 Cv Reduced Port	1.3	6.9	13	17	20	24	26	28	30	32	33
4" (DN100)	Full Port	2.5	29	59	90	113	136	160	184	212	255	310
	0.6 Cv Reduced Port	2.6	17	33	53	72	97	112	130	151	167	195
	0.4 Cv Reduced Port	2.5	13	27	42	54	65	76	88	104	113	124
	0.2 Cv Reduced Port	2.6	11	21	29	36	41	46	51	57	59	64
6" & 8" (DN150 & 200)	Full Port	5.2	35	88	146	207	276	330	393	460	569	648
	0.6 Cv Reduced Port	5.9	33	67	105	145	183	225	279	341	402	442
	0.4 Cv Reduced Port	5.6	28	55	84	114	136	156	189	219	256	282
	0.2 Cv Reduced Port	5.3	16	31	47	63	74	88	102	116	127	132

NOTE: See Graph No. 2 for corresponding  $F_L$  factors.

**TABLE 9**  
**FLOW COEFFICIENTS  $C_v$  – ANTI-CAVITATION TRIM**  
**REVERSE FLOW DIRECTION**

Valve Size	Port	Percent of Plug Open										
		Min.	10%	20%	30%	40%	50%	60%	70%	80%	90%	100%
1" (DN25)	AC1 or LNC	0.4	.7	1.9	3.0	3.9	4.8	5.4	6.4	7.1	7.4	7.6
	AC2 or LND	0.2	0.4	1.2	1.8	2.4	2.9	3.3	3.9	4.4	4.5	4.7
1-1/2" (DN40)	AC1 or LNC	0.7	1.0	3.0	5.2	7.3	9.2	11.2	12.7	13.7	14.3	14.4
	AC2 or LND	0.4	0.6	1.7	2.9	4.1	5.2	6.3	7.2	7.7	8.0	8.1
2" (DN50)	AC1 or LNC	1.5	4.6	8.5	12	16	19	22	25	27	29	30
	AC2 or LND	0.9	2.6	4.8	6.8	9.0	11	12	14	15	16	17
3" (DN80)	AC1 or LNC	3.0	11	18	25	32	38	44	50	55	58	60
	AC2 or LND	1.7	6.2	10	14	18	21	25	28	31	33	34
4" (DN100)	AC1 or LNC	5.8	19	31	43	58	69	81	93	102	109	115
	AC2 or LND	3.3	11	18	24	33	39	46	52	58	61	65
6" & 8" (DN150 & 200)	AC1 or LNC	10.5	30	55	78	103	126	151	174	193	204	210
	AC2 or LND	5.9	17	31	44	58	71	85	97	108	114	118

NOTE: See Graph No. 2 for corresponding  $F_L$  factors.

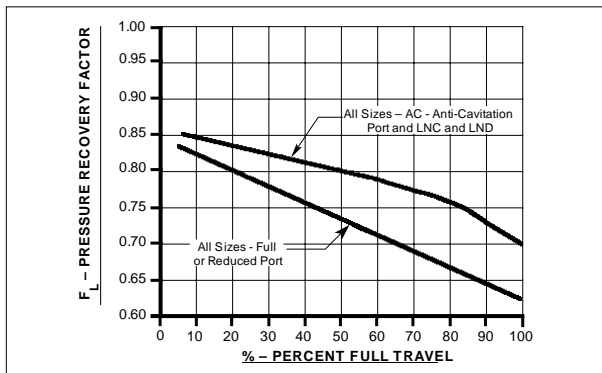

Graph No. 2

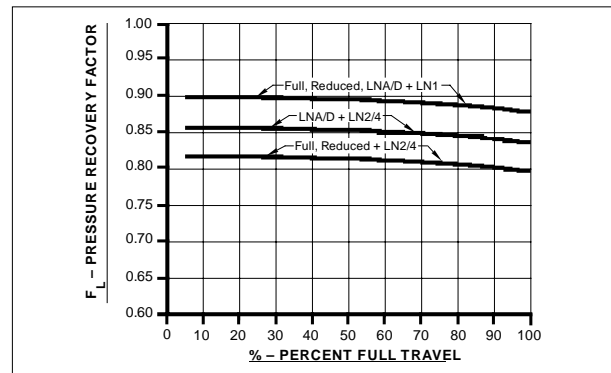

Graph No. 3

**TABLE 10**  
**FLOW COEFFICIENTS  $C_V$  – LO-NOISE TRIM**  
**STD (FORWARD) FLOW DIRECTION**

Valve Size	Trim Insert	Port	Percent of Plug Travel										
			Min.	10%	20%	30%	40%	50%	60%	70%	80%	90%	100%
1-1/2" (DN40)	LN1	Full	0.2	1.7	4.1	6.9	9.8	12.5	15.0	17.3	18.5	19.2	<b>19.9</b>
		0.6 Reduced	0.3	1.7	4.2	6.6	8.7	10.4	11.8	13.0	13.8	14.5	<b>15.0</b>
		0.4 Reduced	0.3	1.7	3.8	6.1	7.8	9.0	9.9	10.5	10.9	11.3	<b>11.6</b>
		0.2 Reduced	0.3	1.7	3.3	4.1	4.5	4.7	4.8	4.8	4.9	5.0	<b>5.1</b>
	LN2	Full	0.2	1.7	4.0	6.7	9.2	11.2	12.9	14.2	14.9	15.3	<b>15.6</b>
		0.6 Reduced	0.3	1.7	4.1	6.4	8.2	9.6	10.7	11.6	12.1	12.5	<b>12.9</b>
		0.4 Reduced	0.3	1.7	3.7	5.9	7.4	8.5	9.2	9.7	10.0	10.3	<b>10.5</b>
		0.2 Reduced	0.3	1.7	3.3	4.0	4.4	4.6	4.7	4.8	4.9	4.9	<b>5.0</b>
	LN1	LNA or LNC	0.5	1.1	3.1	5.4	7.5	9.3	11.1	12.4	13.2	13.7	<b>13.8</b>
		LNB or LND	0.3	0.6	1.8	3.1	4.3	5.4	6.5	7.3	7.9	8.2	<b>8.3</b>
	LN2	LNA or LNC	0.4	1.1	3.1	5.3	7.2	8.7	10.2	11.1	11.7	12.0	<b>12.1</b>
		LNB or LND	0.3	0.6	1.8	3.0	4.2	5.3	6.3	7.1	7.5	7.8	<b>7.9</b>
2" (DN50)	LN1	Full	0.4	5.9	11	18	22	25	28	29	31	32	<b>34</b>
		0.6 Reduced	0.6	3.3	7.8	11.4	15.5	18.4	20.9	23.1	25	27	<b>28</b>
		0.4 Reduced	0.7	4.4	7.6	11.4	14.0	15.5	17.7	19.7	20.9	22.0	<b>23.1</b>
		0.2 Reduced	0.9	3.2	5.4	7.1	8.8	9.7	10.6	11.4	12.3	13.1	<b>13.5</b>
	LN2	Full	0.3	5.8	10.8	15.6	18.3	19.9	21.2	21.9	22.6	23.2	<b>23.6</b>
		0.6 Reduced	0.4	3.3	7.6	10.8	14.1	16.1	17.7	18.9	20.1	20.9	<b>21.5</b>
		0.4 Reduced	0.5	4.3	7.4	10.8	12.9	14.1	15.6	16.9	17.7	18.3	<b>18.9</b>
		0.2 Reduced	0.8	3.2	5.4	6.9	8.5	9.3	10.1	10.8	11.5	12.2	<b>12.5</b>
	LN1	LNA or LNC	0.8	4.3	7.9	10.9	14.1	16.3	18.3	20.1	21.3	22.3	<b>22.8</b>
		LNB or LND	0.6	2.5	4.5	6.3	8.4	9.8	11.3	12.6	13.5	14.4	<b>14.8</b>
	LN2	LNA or LNC	0.6	4.3	7.7	10.4	13.0	14.6	16.0	17.2	17.9	18.5	<b>18.8</b>
		LNB or LND	0.5	2.5	4.5	6.2	8.1	9.4	10.7	11.8	12.5	13.2	<b>13.5</b>
3" (DN80)	LN1	Full	1.2	13	27	40	53	63	71	77	83	89	<b>95</b>
		0.6 Reduced	1.5	9	18	28	36	43	50	58	64	70	<b>74</b>
		0.4 Reduced	1.6	9	18	25	30	35	39	45	50	54	<b>57</b>
		0.2 Reduced	2.1	6.5	12	16	19	23	25	27	29	31	<b>32</b>
	LN2	Full	0.8	13	26	36	44	50	53	56	58	60	<b>62</b>
		0.6 Reduced	1.1	9	17	27	33	38	43	47	50	53	<b>55</b>
		0.4 Reduced	1.3	9	17	24	28	32	35	39	42	45	<b>47</b>
		0.2 Reduced	2.0	6.5	12	16	18	22	24	26	27	29	<b>30</b>
	LN3	Full	0.5	12	24	31	36	39	40	41	42	43	<b>44</b>
		0.6 Reduced	0.8	8.8	17	24	29	32	35	37	39	40	<b>41</b>
		0.4 Reduced	1.1	8.8	17	23	26	29	31	33	35	36	<b>37</b>
		0.2 Reduced	1.8	6.4	12	15	18	20	23	24	25	26	<b>27</b>
	LN1	LNA or LNC	1.1	10	16	20	24	26	28	30	31	31	<b>32</b>
		LNB or LND	1.0	5.8	9.3	13	16	18	20	22	23	24	<b>25</b>
	LN2	LNA or LNC	1.4	10	17	22	28	32	35	39	41	42	<b>43</b>
		LNB or LND	1.2	5.9	9.5	13	17	19	22	25	27	28	<b>29</b>
LN3	LNA or LNC	1.2	10	16	21	25	28	31	33	34	35	<b>35</b>	
	LNB or LND	1.0	5.8	9.4	13	16	19	21	23	25	26	<b>26</b>	

- NOTES: 1. See Graph No. 3 for corresponding  $F_L$  factors.  
2. See Table 6 for  $C_V$ 's of LNA, LNB, LNC or LND in std. flow direction with NO insert.

(Table Continued Next Page)

**TABLE 10 (Continued)**  
**FLOW COEFFICIENTS  $C_v$  – LO-NOISE TRIM**  
**STD (FORWARD) FLOW DIRECTION**

Valve Size	Trim Insert	Port	Percent of Plug Travel										
			Min.	10%	20%	30%	40%	50%	60%	70%	80%	90%	100%
4" (DN100)	LN1	Full	1.8	28	54	78	93	105	116	124	132	141	<b>148</b>
		0.6 Reduced	2.5	16	30	49	64	82	92	102	112	120	<b>126</b>
		0.4 Reduced	2.8	12	26	39	50	59	68	78	88	96	<b>99</b>
		0.2 Reduced	4.0	10	20	28	34	39	43	49	54	57	<b>60</b>
	LN2	Full	1.1	27	48	63	70	75	79	81	83	85	<b>87</b>
		0.6 Reduced	1.6	16	29	44	55	65	70	74	77	80	<b>82</b>
		0.4 Reduced	2.1	12	25	37	45	52	58	63	68	71	<b>73</b>
		0.2 Reduced	3.5	10	20	27	33	37	40	44	48	50	<b>52</b>
	LN3	Full	0.8	26	43	53	57	59	61	62	63	64	<b>65</b>
		0.6 Reduced	1.3	16	28	40	48	54	57	59	61	62	<b>63</b>
		0.4 Reduced	1.7	12	24	34	41	46	50	53	56	57	<b>58</b>
		0.2 Reduced	3.1	10	19	26	31	34	37	40	43	45	<b>46</b>
	LN4	Full	1.3	27	51	70	80	87	93	97	101	105	<b>108</b>
		0.6 Reduced	2.0	16	30	47	60	73	79	85	91	95	<b>98</b>
		0.4 Reduced	2.4	12	25	38	47	55	63	70	77	82	<b>84</b>
		0.2 Reduced	3.7	10	20	27	33	38	42	47	51	54	<b>56</b>
	LN1	LNA or LNC	3.0	18	29	40	52	61	70	78	84	88	<b>91</b>
		LNB or LND	2.3	10	17	23	31	36	42	48	52	55	<b>58</b>
	LN2	LNA or LNC	2.3	18	28	37	47	53	58	63	66	68	<b>69</b>
		LNB or LND	2.0	10	16	22	29	34	39	44	47	49	<b>51</b>
LN3	LNA or LNC	1.9	17	27	35	42	47	50	53	55	56	<b>56</b>	
	LNB or LND	1.8	10	16	22	28	32	36	40	42	44	<b>45</b>	
LN4	LNA or LNC	2.6	18	29	38	50	57	64	70	74	77	<b>79</b>	
	LNB or LND	2.2	10	16	23	30	35	41	46	49	52	<b>54</b>	
6" & 8" (DN150 & 200)	LN2	Full	2.4	34	82	120	146	165	174	181	186	190	<b>193</b>
		0.6 Reduced	3.7	33	64	95	121	139	153	166	176	182	<b>185</b>
		0.4 Reduced	4.8	28	54	80	102	116	127	142	153	163	<b>168</b>
		0.2 Reduced	7.8	16	32	47	63	73	84	96	106	114	<b>117</b>
	LN3	Full	1.6	34	75	100	113	121	124	127	128	130	<b>131</b>
		0.6 Reduced	2.6	32	61	84	100	109	116	122	125	127	<b>128</b>
		0.4 Reduced	3.5	27	52	73	89	97	104	111	116	120	<b>122</b>
		0.2 Reduced	6.5	16	31	45	59	67	76	84	91	96	<b>98</b>
	LN4	Full	3.0	35	85	129	163	190	204	215	224	233	<b>237</b>
		0.6 Reduced	4.5	33	66	99	129	152	173	192	207	218	<b>223</b>
		0.4 Reduced	5.6	28	55	82	108	124	138	157	172	187	<b>195</b>
		0.2 Reduced	8.4	16	32	47	64	74	87	100	112	121	<b>126</b>
	LN2	LNA or LNC	4.7	28	51	69	88	103	117	127	135	139	<b>141</b>
		LNB or LND	3.9	16	29	41	53	64	75	84	91	95	<b>97</b>
	LN3	LNA or LNC	3.7	28	49	65	79	89	98	104	108	110	<b>111</b>
		LNB or LND	3.4	16	29	40	51	60	69	76	81	84	<b>86</b>
LN4	LNA or LNC	5.2	28	51	71	91	108	125	138	148	153	<b>156</b>	
	LNB or LND	4.1	16	29	41	54	65	76	87	95	100	<b>102</b>	

NOTES: 1. See Graph No. 3 for corresponding  $F_L$  factors.  
2. See Table 6 for  $C_v$ 's of LNA, LNB, LNC or LND in std. flow direction with NO insert.

## MOUNTED ACCESSORY SPECIFICATIONS

<b>Positioners:</b>	<p><u>General.</u> Mounted to arm housing. All feedback linkage is enclosed and not exposed directly to elements. Each positioner supplied with 2-gauge cluster; dual scale gauges. Pneumatic output load as required by actuator bench set range. Dedicated airset recommended.</p> <p><u>P/P Pneumatic.</u> Model 9000R. Accepts 3–15 psig (0.2–1.0 Barg); 2-way split ranges 3–9 or 9–15 psig (0.2–0.6, 0.6–1.0 Barg) input signals. Equal % or linear characterization cams (linear cam only for split range applications). Adjustable zero; fixed gain, stroke or damping. SIG and LOAD gauges. Side mounted to arm housing. Optional bypass. See technical bulletin 9000R-TB.</p> <p><u>P/P Pneumatic.</u> Model 9540R. Accepts 3–15 psig (0.2–1.0 Barg); 2-way split ranges 3–9 or 9–15 psig (0.2–0.6 or 0.6–1.0 Barg) input signals. Equal % or linear characterization cams. Adjustable zero, gain, damping, or stroke. SIG and LOAD gauges. Complete with position indicator. Enclosed gauge cluster. End of shaft mounting to arm housing. Bypass included. See technical bulletin 9540R-TB.</p> <p><u>I/P Electro-Pneumatic.</u> Model 9520R. Accepts 4–20 mA; 2-way split ranges 4–12 or 12–20 mA input signals. Equal % or linear characterization cams. NEMA 3 enclosure, intrinsically safe, FM approved. Requires separate electronic “barrier” for proper installation. SUPPLY and LOAD gauges supplied on external gauge cluster block. Complete with position indicator. End of shaft mounting to arm housing. See technical bulletin 9520R-TB.</p>	<b>Airset:</b> Model 5100P instrument air supply regulator. Use with positioners. Bracket mounted to actuator casing. Supplied with gauge for P/P positioners; no gauge with I/P positioner. See technical bulletin 5100P-TB.
	<b>Solenoid Valve:</b> <u>Standard Brass:</u> Available in standard weather-proof model or explosion-proof model. Brass body, 1/4" female NPT connections. Nipple mounted to actuator casing. 120 VAC, 60 Hz power supply.  <u>Gen. Purpose:</u> ASCO #8320G176. <u>X-Proof:</u> ASCO #EF8320G176. <u>Alternate SST:</u> Similar to standard brass unit, <u>except</u> with 303 SST body. <u>Gen. Purpose:</u> ASCO #8320G201. <u>X-Proof:</u> ASCO #EF8320G201.  Standard installation vents actuator and drives valve to fail-safe position upon loss of electrical power.  Consult factory for 230/1/50, 125 VDC, or 24 VDC power supplies, or intrinsically safe (IS) service.	
	<b>Position Indicating Switches:</b>  <u>With 9000R P/P Positioner.</u> Proximity Controls Model 12ADO Mark I. Rotary trip switch. Mounted to end of shaft; direct drive. Includes 2-SPDT switches. Factory calibrated for “full open” and “full closed” positions. Aluminum enclosure. Explosion-proof.  <u>Without Positioner.</u> Same as with 9000R P/P positioner.  <u>With 9520R I/P Positioner.</u> Go Systems Series 70, Proximity probe-type, magnetic switches. Each probe contains 1-SPDT switch. Explosion-proof. 18-8 SST enclosure.  <u>With 9540R P/P Positioner.</u> Same as with 9520R I/P positioner.	
<b>Air Tubing:</b>	<p>Standard instrument air tubing is Imperial-Eastman “Impolene” thermo-plastic tubing with brass fittings.</p> <p>Optional copper tubing with brass fittings, or SST tube and fittings.</p> <p>Optional overpressure protection relief valve to prevent overpressurizing actuator and causing internals damage. Available in brass or SST.</p>	<b>Other Accessories:</b> Bypass for 9000R P/P positioner. 764 P/PD pressure controller. I/P transducer. Lockup valve. Position transmitter. “Smart” I/P positioner.

**FIGURE 12:**  
ORIENTATION – MOUNTING POSITIONS  
WITH MODEL 9000R P/P POSITIONER

**NOTES:** 1. Flangeless valve design indicated; integral flanged units follow same orientation.  
2. See Figure 15 for front flange bolt hole requirements.

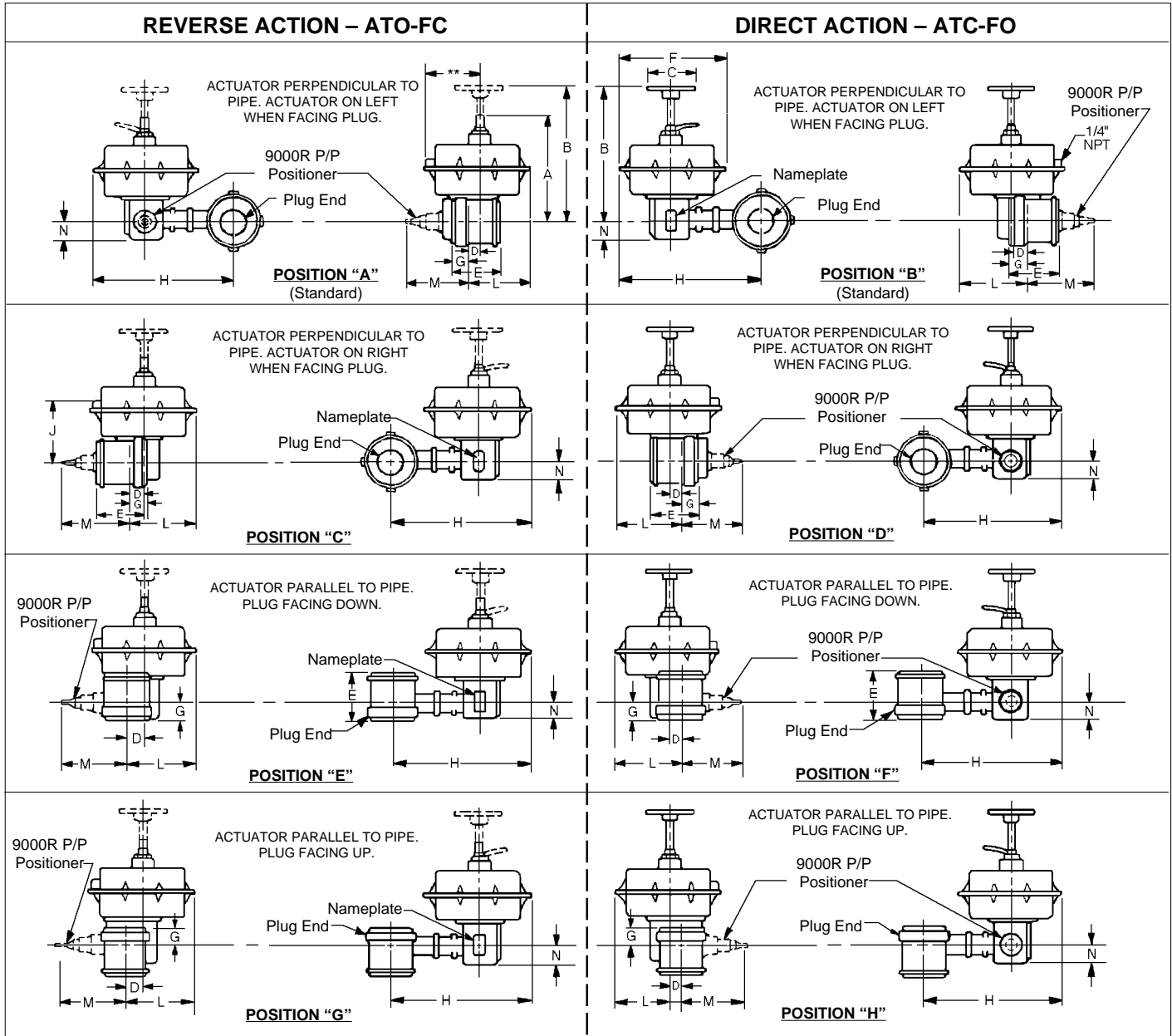

Body Size - in.	DIMENSIONS – ENGLISH UNITS - in. & lbs.												Wt. - lbs.	
	A	B	C	D	E*	F**	G	H	J	L	M	N	Flangeless	Flanged
1"	13.31	16.56	4.00	1.19	4.00	10.50	1.08	14.75	7.69	6.44	9.50	2.5	39	46
1-1/2"	13.31	16.56	4.00	1.19	4.50	10.50	1.42	15.19	7.69	6.44	9.50	2.5	41	54
2"	13.31	16.56	4.00	1.19	4.88	10.50	1.42	15.19	7.69	6.44	9.50	2.5	45	59
3"	16.56	21.62	8.00	1.62	6.50	16.38	2.05	23.38	10.0	9.81	9.50	3.0	93	119
4"	16.56	21.62	8.00	1.62	7.62	16.38	2.61	23.94	10.0	9.81	9.50	3.0	115	149
6"	16.56	21.62	8.00	1.62	9.00	16.38	4.00	25.00	10.0	9.81	9.50	3.0	168	222
8"	16.56	21.62	8.00	1.62	9.56	16.38	4.00	25.00	10.0	9.81	9.50	3.0	223	320
Body Size - DN	DIMENSIONS – METRIC UNITS - mm & kg												Wt. - kg.	
	A	B	C	D	E*	F**	G	H	J	L	M	N	Flangeless	Flanged
25	338	421	102	30	102	267	27	375	195	164	241	64	18	21
40	338	421	102	30	114	267	36	386	195	164	241	64	19	24
50	338	421	102	30	124	267	36	386	195	164	241	64	21	27
80	421	549	203	41	165	416	52	594	254	249	241	76	43	54
100	421	549	203	41	194	416	66	608	254	249	241	76	53	67
150	421	549	203	41	229	416	102	635	254	249	241	76	77	100
200	421	549	203	41	243	416	102	635	254	249	241	76	101	145

\* Dimension "E" is face-to-face for both flangeless and flanged bodies. \*\* Divide "F" measurement in half for 1/4" NPT connection dimension.

**FIGURE 13:**  
**ORIENTATION – MOUNTING POSITIONS**  
**WITH MODELS 9520R I/P AND 9540R P/P POSITIONERS**

**NOTES:** 1. Flangeless valve design indicated; integral flanged units follow same orientation.  
 2. See Figure 15 for front flange bolt hole requirements.

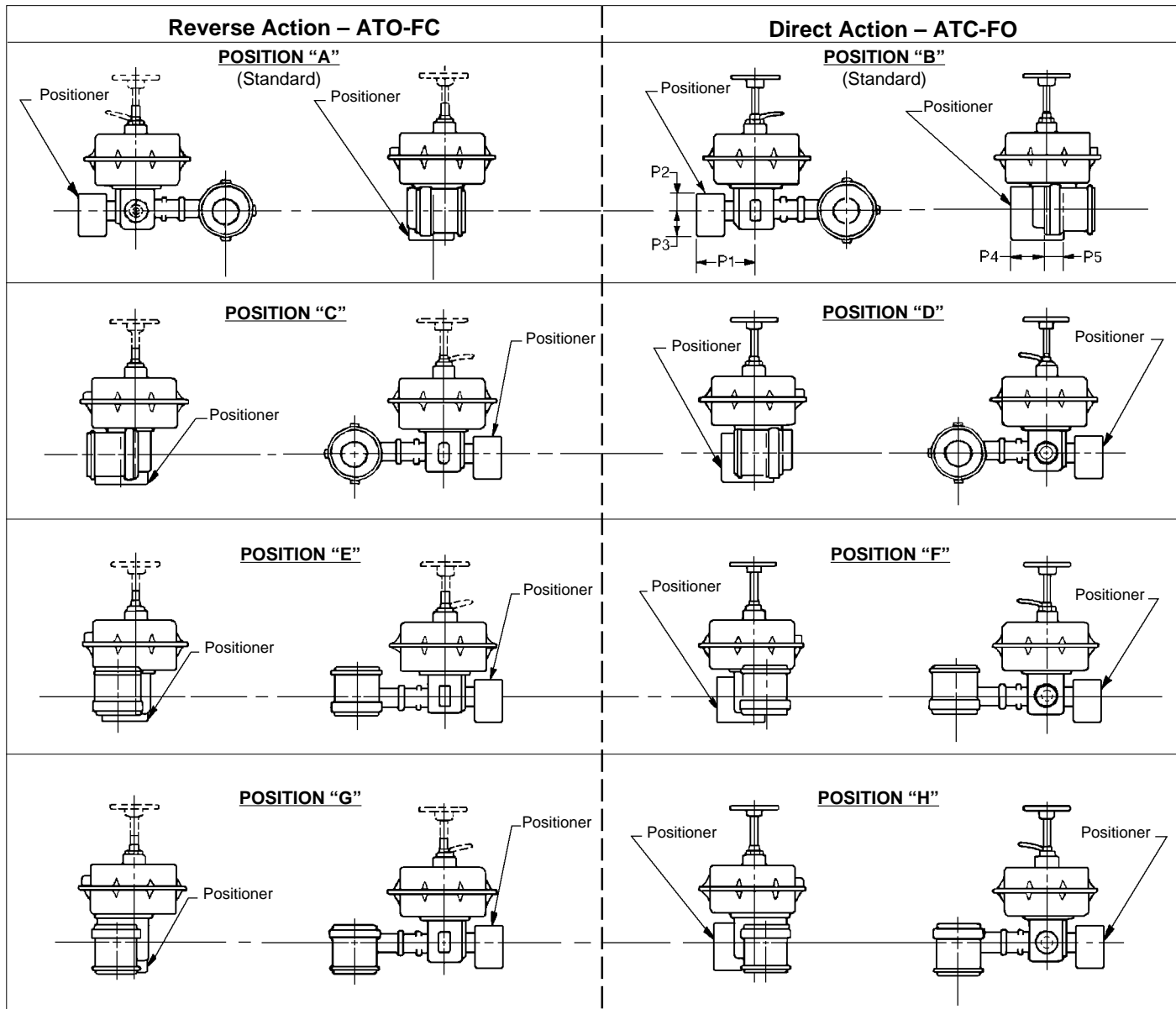

NOTE: All basic valve dimensions are as indicated in Figure 12.

DIMENSIONS – ENGLISH UNITS - in. & lbs.													
	9520R I/P Positioner						9540R P/P Positioner						
Body Size - in.	P1	P2	P3	P4	P5	Wt - lbs. *	P1	P2	P3	P4	P5	Wt. - lbs. *	
1", 1-1/2", 2"	9.00	1.75	4.81	6.12	1.94	5.5	8.60	1.75	3.69	4.88	1.99	3.5	
3", 4", 6", 8"	8.94	1.75	4.81	6.12	1.94	5.5	8.56	1.75	3.69	4.88	1.94	3.5	
DIMENSIONS – METRIC UNITS - mm & kg													
	9520R I/P Positioner						9540R P/P Positioner						
Body Size - DN	P1	P2	P3	P4	P5	Wt. - kg. *	P1	P2	P3	P4	P5	Wt. - kg. *	
25, 40, 50	229	44	122	155	50	2.5	220	44	94	124	50	1.5	
80, 100, 150, 200	227	44	122	155	50	2.5	217	44	94	124	50	1.5	

\* Add to weight of basic valve

**FIGURE 14:**  
 "FLANGELESS" BODY DESIGN  
 LINE BOLTING REMOVAL CLEARANCE

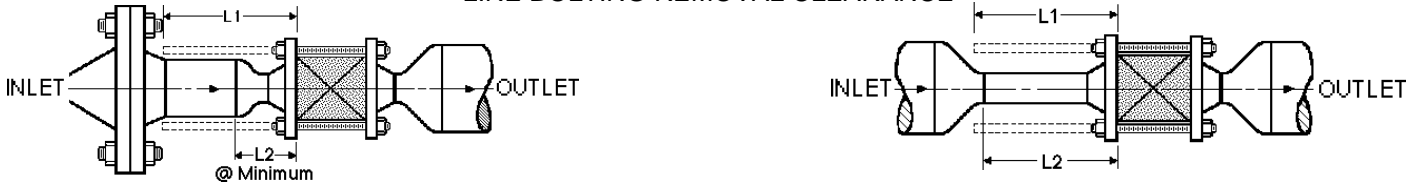

**NOTE:** Locate spool piece between Inlet flange and reducer. **DO NOT** locate spool at Outlet flange.

Body Size	Reducer Size	150# Figs.		300# Figs.		600# Figs.	
		L1	L2	L1	L2	L1	L2
1" (DN25)	None	8.38 (213)	Min	8.75 (222)	Min	8.94 (227)	Min
	1-1/2"x1"		Min				
	2"x1"		Min				
	2-1/2"x1"		7.38 (187)				
1-1/2" (DN40)	None	8.44 (214)	Min	9.88 (251)	Min	10.12 (257)	Min
	2"x1-1/2"		Min		Min		
	2-1/2"x1-1/2"		Min		Min		
	3"x1-1/2"		Min		Min		
	4"x1-1/2"		7.44 (198)		8.88 (226)		9.12 (232)
2" (DN50)	None	10.06 (256)	Min	10.13 (257)	Min	10.50 (267)	Min
	2-1/2"x2"		Min				
	3"x2"		Min				
	4"x2"		9.00 (229)				
3" (DN80)	None	11.50 (292)	Min	13.44 (341)	Min	13.88 (353)	Min
	4"x3"		Min		Min		
	6"x3"		10.25 (260)		12.19 (310)		12.63 (321)
4" (DN100)	None	12.50 (318)	Min	13.56 (344)	Min	16.00 (406)	Min
	6"x4"		Min		Min		
	8"x4"		11.00 (279)		12.00 (305)		14.50 (368)
	10" x 4"						
6" (DN150)	None	14.81 (376)	Min	16.25 (413)	Min	18.63 (473)	Min
	8"x6"		Min		Min		
	10"x6"		Min		Min		
	12"x6"		12.75 (324)		14.00 (356)		16.56 (421)
	14"x6"						
8" (DN200)	None	15.50 (394)	Min	18.75 (476)	Min	20.38 (518)	Min
	10"x8"		Min		Min		
	12"x8"		Min		Min		
	14"x8"		13.43 (341)		16.68 (424)		17.93 (455)
	16"x8"						

**FIGURE 15:**  
 FRONT FLANGE BOLT HOLE DESIGN

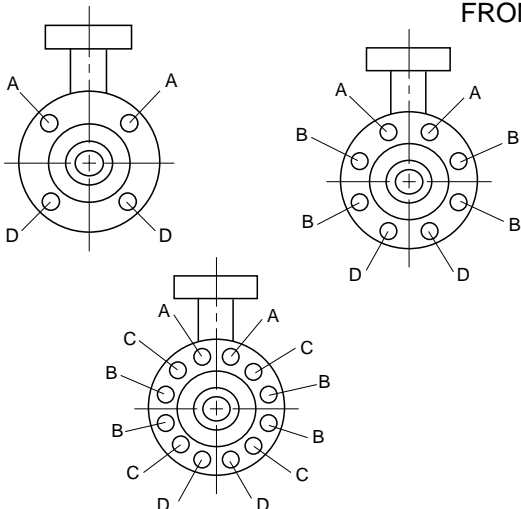

All Bolt Holes Straddle Centerlines

Body Size	Pressure Class	Front Flange Bolt Holes					
		Total #	A	B	C	D	Threads
1" (DN25)	150	4	D & T	-	-	D & T	1/2"-13UNC
	300/600	4	D & T	-	-	D & T	5/8"-11UNC
1-1/2" (DN40)	150	4	D & T	-	-	D & T	1/2"-13UNC
	300/600	4	D & T	-	-	D & T	3/4"-10UNC
2" (DN50)	150	4	H	-	-	H	5/8"-11UNC
	300/600	8	D & T	H	-	H	5/8"-11UNC
3" (DN80)	150	4	H	-	-	H	5/8"-11UNC
	300/600	8	D & T	H	-	H	3/4"-10UNC
4" (DN100)	150	8	D & T	H	-	H	5/8"-11UNC
	300	8	D & T	H	-	H	3/4"-10UNC
	600	N/A	N/A	N/A	N/A	N/A	N/A
6" & 8" (DN150 & 200)	150	8	D & T	D & T	-	D & T	3/4"-10UNC
	300	12	D & T	H	H	H	7/8"-9UNC
	600	N/A	N/A	N/A	N/A	N/A	N/A

"D & T" = Bolt hole drilled and tapped "H" = Bolt hole, plain  
 "N/A" = Not available





# LO-NOISE SERVICE

TABLE 3

Body Design, End Conns., Pressure Class				
Flange Pressure Class	"Flangeless" Line Bolting √			
	None	Opt-7A Alloy Steel	Opt-7C 'S.H.-SST	
150#	0	1	7	
300#	0	2	8	
600#	0	3	9	
Flange Pressure Class	Integral Flanged			CODE
	DI	CS	SST	
None	—	—	—	0
150#	No	Yes	Yes	A
300#	No	Yes	Yes	B
600#	No	*	*	*C

TABLE 4

Pipe Position	Mtg. Position	Actuator Action	CODE
Horizontal	A	ATO	A
	B	ATC	B
	C	ATO	C
	D	ATC	D
Vertical	E	ATO	E
	F	ATC	F
	G	ATO	G
	H	ATC	H

TABLE 5

Trim Designation Nos. and Back-End Lo-Noise Inserts										
Lo-Noise Insert	Body Sizes	Trim Designation Nos.								
		Standard-General-SST					Corrosive Chemical		Flashing Vapor	
		ST1	ST2	ST3	ST6	ST7 *	CT1 **	CT2 **	ST4	ST5
LN1	1-1/2"-4"	A	B	C	D	9	—	—	—	—
LN2	1-1/2"-8"	F	G	H	E	@	J	K	—	—
LN3	3"-8"	L	M	N	6	&	P	T	—	—
LN4	4"-8"	U	V	W	7	\$	Y	Z	—	—
None	All	1	2	3	8	—	4	5	R	S

√ CS & SST bodies are not available "Flangeless" in 8" size.

1 S.H.= Strain-Hardened

2 No end connection flange bolting is available for integral flanged units.

\* 1", 1-1/2", 2" & 3" body sizes only.

TABLE 2

Body	Material	Size	Full Port	Reduced Port			Lo-Noise Port				NACE Opt-40 Acceptable?	
				CS	SST	SST	SST	SST	SST	SST		SST
DI	—	1"-3"	—	1	A	B	C	D	&	W	\$	NO
		4"-8"	2	—	—	—	—	—	—	—	—	—
CS (Non-NACE)	—	1"-3"	—	3	E	F	G	H	J	K	L	NO
		4"-8"	4	—	—	—	—	—	—	—	—	—
CS (NACE)	—	1"-3"	—	5	N	P	R	S	T	U	V	YES
		4"-8"	6	—	—	—	—	—	—	—	—	—
SST (NACE or Non-NACE)	ALL	—	7	Z	8	9	(	M	Y	Q	YES	

\* Select Opt-40 NACE service in Table 8.

TABLE 1

Size	Actuator	Fail Position	CODE	
			W/Handwheel STD.	NO Handwheel OPT-3
1"	48R-01, ATO, 5-15 psig	Close	1	B
	48D-01, ATC, 5-15 psig	Open	A	T
1-1/2"	48R-01, ATO, 5-15 psig	Close	G	D
	48D-01, ATC, 5-15 psig	Open	C	U
2"	48R-01, ATO, 5-15 psig	Close	2	F
	48D-01, ATC, 5-15 psig	Open	E	V
3"	148R-01, ATO, 5-13 psig	Close	3	J
	148D-01, ATC, 5-13 psig	Open	H	W
4"	148R-02, ATO, 10-26 psig	Close	M	P
	148D-02, ATC, 10-26 psig	Open	N	Z
6"	148R-02, ATO, 10-26 psig	Close	6	S
	148D-02, ATC, 10-26 psig	Open	R	7
8"	148R-02, ATO, 10-26 psig	Close	8	5
	148D-02, ATC, 10-26 psig	Open	&	9

Trim Variation

\* Class IV guaranteed, approaching Class VI.

\*\* Trims suitable for Opt-40 NACE service.

\*\*\* LNA/D without an insert.

√ LNC/D without an insert

TABLE 6

Temp. Range °F	Service	Opt. Nos.	Sealing Selections			CODE
			Gasket	Material	Packing Design	
-20≤T≤400 w/insulated bonnet	Low-Moderate-High Temp	Std.	Std. Non-Asb.	Std. TFE	Std. LL	A
		-38V	Non-Asb.	TFE	LL	B
-20≤T≤750 w/exposed bonnet	HighTemp	Std.	Std. Non-Asb.	TFE	Non-LL	C
		-38J	Non-Asb.	TFE	Non-LL	C
-20≤T≤750	HighTemp	-38HT	Std. Non-Asb.	Graphite	LL	G*

\* Positioner required

LL = Live-Loaded.

TABLE 7

P/P Pneumatic Model #9000R	P/P Positioner		CODE
	CODE w/Airset	CODE w/o Airset	
Direct 3-15 psig	0-30 psig	0-60 psig	R
Reverse 15-3 psig	1	A	S
Split Rg. Direct 3-9 psig *	2	B	V
Split Rg. Direct 9-15 psig *	3	C	W
Split Rg. Reverse 15-9 psig *	4	D	X
Split Rg. Reverse 9-3 psig *	5	E	Y
	6	F	Z

\* Must specify "Linear" characteristic in Table 9.

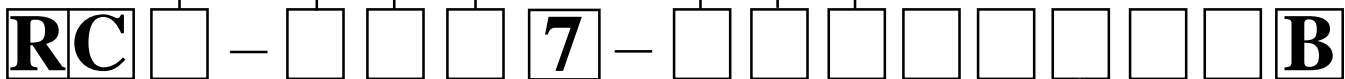

"RANGER QCT" ROTARY CONTROL VALVE

TABLE 8

Option	Opt. No.	CODE
None	—	0
NACE	-40	N

TABLE 9

Type of Positioner	Positioner Accessories					
	Gauges	Characteristic	Tubing			Copper
			Std. Impolene	SST	CODE	
None	—	—	—	—	—	0
Pneumatic (P/P) 9000R	√	√	—	—	—	D
	√	√	—	—	—	E

TABLE 10

Position Limit Switches				Position X-Mitter W/Limit Switches					
Mfg/Model	Type	No. SPDT Swtchs/Unit	Trip Position	CODE	Mfg/Model	Type	No. SPDT Swtchs/Unit	Trip Position	CODE
None	—	—	—	0	None	—	—	—	0
Proximity Controls #12ADO	Rotary Trip X-Proof	2	Full Open & Closed	B	Proximity Controls #15VDO	Proximity w/end of Travel Limit Switches X-Proof, 4-20mA	2	Full Open & Closed	C

TABLE 11

Accessories	CODE
None (other than indicated on this Coder Sheet)	0
Valve Mounted Accessories-Any of the following: Pneumatic Posit. Bypass 3-way Solenoid Valve 764P Press. Controller Extra Airset(s) I/P Transducer Lockup Valve	9
Travel Stop Screw	A
Travel Stop Screw plus "Code 9" Above	Z

\* Use of a "9" Code requires that a "99 Coder" Sheet be completed.

TABLE 12

Painting and Cleaning	Option	Standard Commercial Cleaning	Cleaned to Spec. #S-1542	Cleaned to Spec. #S-1134 * (O <sub>2</sub> Cleaned)
		CODE	CODE	CODE
Std/Commercial Epoxy	—	0	3	6
Epoxy-Basic Valve	-95	1	4	7
Epoxy-Basic Valve plus Accessories	-95	2	5	8

\* SST bodies only. Cleaned for oxygen service.

# GENERAL SERVICE

TABLE 3

Body Design, End Conns., Pressure Class				
Flange Pressure Class	"Flangeless" Line Bolting			CODE
	None	Opt-7A Alloy Steel	Opt-7C 'S.H.-SST	
150#	0	1	7	/
300#	0	2	8	
600#	0	3	9	
Flange Pressure Class	2 Integral Flanged			
None	DI	CS	SST	0
150#	No	Yes	Yes	A
300#	No	Yes	Yes	B
600#	No	*	*	*C

CS & sst bodies are not available "Flangeless" in 8" size.  
 1 S.H.= Strain-Hardened  
 2 No end connection flange bolting is available for integral flanged units.  
 \* 1", 1-1/2", 2" & 3" body sizes only.

TABLE 2

Materials - Body, Seal Retainer (Port), Cage, Plug Bearings									
Material	Body Size	Full Port CS	SST	Reduced Port			Anti-Cav.		*NACE
				SST	SST	SST	AC1	AC2	Opt-40 Acceptable?
DI	1"-3"	-	1	A	B	C	W	K	NO
	4"-8"	2	-	-	-	-	-	-	-
CS	1"-3"	-	3	E	F	G	T	S	NO
	4"-8"	4	-	-	-	-	-	-	-
SST	1"-3"	-	5	N	P	R	U	V	YES
	4"-8"	6	-	-	-	-	-	-	-
SST (NACE or Non NACE)	All	-	7	Z	8	9	Y	&	YES
Seat Design	Both Comp or Metal						Mtl. Only		/
Flow Direction	Std. or Rev.						Rev. Only		/

\* Select Opt-40 NACE Service in Table 8.

TABLE 1

Size	Actuator	Fail Position	CODE	
			W/Handwheel	NO Handwheel
			STD.	OPT-3
1"	48R-01, ATO, 5-15 psig	Close	1	B
	48D-01, ATC, 5-15 psig	Open	A	T
1-1/2"	48R-01, ATO, 5-15 psig	Close	G	D
	48D-01, ATC, 5-15 psig	Open	C	U
2"	48R-01, ATO, 5-15 psig	Close	2	F
	48D-01, ATC, 5-15 psig	Open	E	V
3"	148R-01, ATO, 5-13 psig	Close	3	J
	148D-01, ATC, 5-13 psig	Open	H	W
4"	148R-02, ATO, 10-26 psig	Close	M	P
	148D-02, ATC, 10-26 psig	Open	N	Z
6"	148R-02, ATO, 10-26 psig	Close	6	S
	148D-02, ATC, 10-26 psig	Open	R	7
8"	148R-02, ATO, 10-26 psig	Close	8	5
	148D-02, ATC, 10-26 psig	Open	&	9

Basic Body/  
Trim Material

TABLE 4

Pipe Position	Mounting Position	Actuator Action	CODE
Horizontal	A	ATO	A
	B	ATC	B
	C	ATO	C
	D	ATC	D
Vertical	E	ATO	E
	F	ATC	F
	G	ATO	G
	H	ATC	H

End Conn.

Trim Variation  
Mtg. Posit.

TABLE 5

Service/Trim Designation #	Flow Direct.	Body Size	Insert	CODE	Service/Trim Designation #	Flow Direct.	Body Size	Insert	CODE		
Std. - General - SST	ST1	Std	All	None	1	Corrosive Chemical	CT1	Std	All	None	A
	ST2	Std	All	None	2		CT2	Std	All	None	B
	ST3	Std	All	None	3		CT3	Rev	All	None	C
	ST4	Rev	All	None	4		CT4	Rev	All	None	D
	ST5	Rev	All	None	5		CT5	Rev	All	None	E
	ST6	Std	All	None	R						
	ST7*	Std.	All	None	Q						
Abrasive Erosion	AT1	Rev	1-1/2"-8"	Abr.Slv.	J						
	AT2	Rev	1-1/2"-8"	Abr.Slv.	K						
	AT3	Rev	All	None	L						
	AT4	Rev	1-1/2"-8"	Abr. Slv.	M						
	AT5	Rev	All	None	N						

\*Class IV guaranteed, approaching Class VI

TABLE 6

Temp. Range °F	Service	Opt. Nos.	Sealing Selections			CODE
			Gasket	Packing		
				Material	Design	
-20≤T≤400 w/insulated bonnet; -20≤T≤750 w/exposed bonnet	Low-Moderate-High Temp	Std.	Std. Non-Asb.	Std. TFE	Std. LL	A
			-38V	Non-Asb. TFE	LL	B
-20≤T≤750	HighTemp	-38J	Std. Non-Asb.	TFE	Non-LL	C
			-38HT	Non-Asb. Graphite	LL	G

LL = Live-Loaded.

TABLE 7

Positioners with ISO Namur Mounting						
I/P Positioner Model #9520R	CODE			P/P Positioner Model #9540R	CODE	
	With Airset 0-30 psig	w/o Airset 0-60 psig	w/o Airset		With Airset 0-30 psig	w/o Airset 0-60 psig
4-20 mA Direct	A	N	G	3-15 psig Direct	1	7
20-4 mA Reverse	B	P	H	15-3 psig Reverse	2	8
Split Rg. Direct 4-12 mA	C	T	J	Split Rg. Direct 3-9 psig	3	9
Split Rg. Direct 12-20 mA	D	U	K	Split Rg. Direct 9-15 psig	4	\$
Split Rg. Reverse 20-12 mA	E	@	L	Split Rg. Reverse 15-9 psig	5	&
Split Rg. Reverse 12-4 mA	F	Q	M	Split Rg. Reverse 9-3 psig	6	/
						Z
						CODE #
						0

Use "98" coder sheet to select Smart I/P Positioner Customer Supplied Positioner

When ordering a valve per one of Cashco's special dwgs, the Code "X" and the 5-digit number following override all other options. Otherwise, proceed with following.

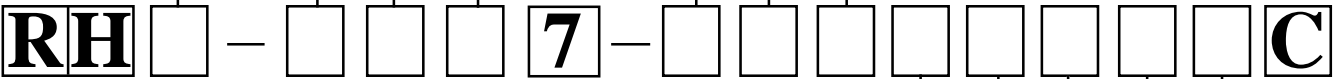

"RANGER QCT" ROTARY CONTROL VALVE WITH POSITIONERS "9520R" or "9540R"

TABLE 8

Flow Direc.	Non-NACE			NACE	
	Option	Opt. #	CODE	Opt. #	CODE
-	None	-	0	-40	N
Std., Rev.	Abrasion Sleeve *	-AS	A	AS+40	1
Rev. Only	Slurry Trim **	-18	B	-18+40	2
	Abrasive Service**	-19	C	-19+40	3

\* Do not re-specify if Trim Design. Nos. AT1, AT2 or AT4 are selected.  
 \*\* Do not re-specify if Trim Design. No. AT4 is selected.

TABLE 9

Positioner Accessories/Tubing				
TUBING				
CHARACTERISTIC	Std. Impolene	Copper	SST	CODE
=%				
√				G
				H
				1
				2
				4
				5

Positioner Accessories

Accessories

Painting

TABLE 11

Accessories	CODE
None (other than indicated on this Coder Sheet)	0
Valve Mounted Accessories- Any of the following: Pneumatic Position Bypass 3-way Solenoid Valve 764P Pressure Controller Extra Airset(s) I/P Transducer Lockup Valve	9
Travel Stop Screw	A
Travel Stop Screw plus "Code 9" Above	Z

\* Use of a "9" Code requires that a "99 Coder" Sheet be completed.

TABLE 10

Proximity Limit Switches									
Mfgr/Model	Type	No. Switches	Valve Plug	CODE	Mfgr/Model	Type	No. Switches	Valve Plug	CODE
None	-	-	-	0	None	-	-	-	0
"GO" Series	Gen. Purpose	1	Open	1	"GO" Series	Hazardous Location Class I & II	1	Open	4
73-13528 -A1		1	Closed	2	73-13523 -A1	All Groups	1	Closed	5
		2	Open & Closed	3			2	Open & Closed	6

TABLE 12

Painting and Cleaning	Option	Sealing Selections		
		Std Commercial Cleaning	Cleaned to Spec. #S-1542	Cleaned to Spec. #S-1134 * (O <sub>2</sub> Cleaned)
		CODE	CODE	CODE
Std/Commercial Epoxy	-	0	3	6
Epoxy-Basic Valve	-95	1	4	7
Epoxy-Basic Valve plus Accessories	-95	2	5	8

\* SST bodies only. Cleaned for oxygen service.

# CRYOGENIC SERVICE

TABLE 3

Body Design, End Conns., Pressure Class			
Flange Pressure Class	"Flangeless" Line Bolting <sup>√</sup>		
	None	Opt-7C 1 S.H.-SST	
CODE			
150#	0	7	
300#	0	8	
Flange Pressure Class	2 Integral Flanged		CODE
	SST		
None	—		0
150#	Yes	A	
300#	Yes	B	
600#	*		C*

√ CS & SST bodies are not available "Flangeless" in 8" size.  
 1 S.H.= Strain-Hardened  
 2 No end connection flange bolting is available for integral flanged units.  
 \* 1", 1-1/2", 2" & 3" body sizes only.

TABLE 2

Materials - Body, Seal Retainer (Port), Cage, Plug Bearings							
Body	Full Port	Reduced Port			Anti-Cav		
		0.6	0.4	0.2	AC1	AC2	
Material	Size	SST	SST	SST	SST	SST	SST
SST	All	D	H	J	M	L	Q
Seat Design	Both Composition or Metal					Mtl. Only	
Flow Direction	Standard or Reverse					Rev. Only	

TABLE 1

Size	Actuator	Fail Position	CODE	
			W/Handwheel	NO Handwheel
			STD.	OPT-3
1"	48R-01, ATO, 5-15 psig	Close	1	B
	48D-01, ATC, 5-15 psig	Open	A	T
1-1/2"	48R-01, ATO, 5-15 psig	Close	G	D
	48D-01, ATC, 5-15 psig	Open	C	U
2"	48R-01, ATO, 5-15 psig	Close	2	F
	48D-01, ATC, 5-15 psig	Open	E	V
3"	148R-01, ATO, 5-13 psig	Close	3	J
	148D-01, ATC, 5-13 psig	Open	H	W
4"	148R-02, ATO, 10-26 psig	Close	M	P
	148D-02, ATC, 10-26 psig	Open	N	Z
6"	148R-02, ATO, 10-26 psig	Close	6	S
	148D-02, ATC, 10-26 psig	Open	R	7
8"	148R-02, ATO, 10-26 psig	Close	8	5
	148D-02, ATC, 10-26 psig	Open	8	9

Basic Body/  
Trim Mat'l

TABLE 4

Pipe Position	Mounting Position	Actuator Action	CODE
Horizontal	A	ATO	A
	B	ATC	B
	C	ATO	C
	D	ATC	D
Vertical	E	ATO	E
	F	ATC	F
	G	ATO	G
	H	ATC	H

TABLE 5

Cryogenic Trim Designation Nos.					
Low Temp Limit = -150°F			Low Temp Limit = -325°F		
Trim Designation No.	Flow Direction	CODE	Trim Designation No.	Flow Direction	CODE
ST1	Std.	1	ST2	Std.	2
ST6	Std.	R	ST5	Rev	5
ST7*	Std.	Q	CT3	Rev	C
CY4	Std.	6**	CT4	Rev	D
CT1	Std.	A	CY1	Std	F
CT2	Std.	B	CY2	Std	G**
			CY3	Rev	H

\* Class IV guaranteed, approaching Class VI.  
 \*\* Recommended for liquid service without flashing or cavitation.

TABLE 6

Cryogenic Sealing Selections					
Service	Opt. Nos.	Gasket	Packing		CODE
			Material	Design	
All Fluids	Std. -38J	Std. Non-Asb.	TFE	LL	A
LL = Live-Loaded					C

TABLE 7

Positioners with ISO Namur Mounting						
I/P Positioner	CODE			P/P Positioner	CODE	
	With Airstet	w/o Airstet	Model #9520R		With Airstet	w/o Airstet
Model #9520R	0-30 psig	0-60 psig	Airstet	Model #9540R	0-30 psig	0-60 psig
4-20 mA Direct	A	N	G	3-15 psig Direct	1	7
20-4 mA Reverse	B	P	H	15-3 psig Reverse	2	8
Split Rg. Direct	C	T	J	Split Rg. Direct	3	9
4-12 mA				3-9 psig		
Split Rg. Direct	D	U	K	Split Rg. Direct	4	5
12-20 mA	E	@	L	9-15 psig	4	5
Split Rg. Reverse				20-12 mA		
Split Rg. Reverse	F	Q	M	Split Rg. Reverse	6	7
12-4 mA	F	Q	M	15-9 psig	6	7
Split Rg. Reverse				12-4 mA		
						CODE
Use "98" coder sheet to select Smart I/P Positioner						#
Customer Supplied Positioner						0

When ordering a valve per one of Cashco's special dwgs, the Code "X" and the 5-digit number following override all other options. Otherwise, proceed with following.

**RH** — **7** — **C**

**"RANGER QCT" ROTARY CONTROL VALVE  
CRYOGENIC (-36)  
WITH POSITIONERS "9520R" or "9540R"**

TABLE 8

Option	Option No.	CODE
Cryogenic	-36	4
Cryogenic + Abr. Sleeve	-36 + AS	5

TABLE 9

Positioner Accessories/Tubing				
CHARACTERISTIC	LINEAR	TUBING		
		Std. Impolene	Copper	SST
=%	—	CODE	CODE	CODE
√	—	G	1	4
—	√	H	2	5

TABLE 10

Proximity Limit Switches								
Mfgr/Model	Type	No. Switches	Valve Plug	CODE	Mfgr/Model	Type	No. Switches	Valve Plug
None	—	—	—	0	None	—	—	—
"GO" Series	Gen. Purpose	1	Open	1	"GO" Series	Hazardous Location	1	Open
73-13528-A1	Purpose	1	Closed	2	73-13523-A1	Class I & II All Groups	1	Closed
		2	Open & Closed	3			2	Open & Closed

TABLE 11

Accessories	CODE
None (other than indicated on this Coder Sheet)	0
Valve Mounted Accessories- Any of the following: Pneumatic Position Bypass 3-way Solenoid Valve 764P Pressure Controller Extra Airstet(s) I/P Transducer Lockup Valve	9
Travel Stop Screw	A
Travel Stop Screw plus "Code 9" Above	Z

\* Use of a "9" Code requires that a "99 Coder" Sheet be completed.

TABLE 12

Painting and Cleaning	Option	CODE
Std/Commercial Epoxy	—	6
Epoxy-Basic Valve	-95	7
Epoxy-Basic Valve plus Accessories	-95	8
		Cleaned to Spec. #S-1134 (O <sub>2</sub> Cleaned)

# LO-NOISE SERVICE

TABLE 3

Body Design, End Conns., Pressure Class				
Flange Pressure Class	"Flangeless" Line Bolting √			
	None	Opt-7A Alloy Steel	Opt-7C 1'S.H.-SST	
150#	0	1	7	
300#	0	2	8	
600#	0	3	9	
Flange Pressure Class	Integral Flanged			CODE
	DI	CS	SST	
None	—	—	—	0
150#	No	Yes	Yes	A
300#	No	Yes	Yes	B
600#	No	*	*	C

TABLE 4

Pipe Position	Mounting Position	Actuator Action	CODE
Horizontal	A	ATO	A
	B	ATC	B
	C	ATO	C
	D	ATC	D
Vertical	E	ATO	E
	F	ATC	F
	G	ATO	G
	H	ATC	H

TABLE 5

Trim Designation Nos. and Back-End Lo-Noise Inserts										
Lo-Noise Insert	Body Sizes	Trim Designation Nos.								
		Standard-General-SST					Corrosive Chemical		Flashing Vapor	
		ST1	ST2	ST3	ST6	ST7*	CT1**	CT2**	ST4	ST5
LN1	1-1/2"-4"	A	B	C	D	9	—	—	—	—
LN2	1-1/2"-8"	F	G	H	E	@	J	K	—	—
LN3	3"-8"	L	M	N	6	&	P	T	—	—
LN4	4"-8"	U	V	W	7	\$	Y	Z	—	—
None	All	1	2	3	8	—	4	5	R	S

√ CS & SST bodies are not available "Flangeless" in 8" size.  
 1 S.H. = Strain Hardened  
 2 No end connection flange bolting is available for integral flanged units.  
 \* 1", 1-1/2", 2" & 3" bodies only.

TABLE 2

Body Material	Size	Full Port		Reduced Port			Lo-Noise Port				NACE Opt-40 Acceptable? *
		CS	SST	0.6	0.4	0.2	LNA	LNB	LNC	LND	
D <sup>1</sup>	1"-3"	—	1	A	B	C	D	&	W	\$	NO
	4"-8"	2	—	E	F	G	H	J	K	L	NO
CS (Non-NACE)	1"-3"	—	3	N	P	R	S	T	U	V	YES
	4"-8"	4	—	—	—	—	—	—	—	—	YES
SST (NACE or Non-NACE)	1"-3"	—	5	—	—	—	—	—	—	—	YES
	4"-8"	6	—	Z	8	9	[	M	Y	Q	YES

\* Select Opt-40 NACE service in Table 8.

TABLE 6

Temp. Range °F	Service	Opt. Nos.	Sealing Selections			CODE
			Gasket	Packing		
				Material	Design	
-20≤T≤400 w/insulated bonnet; -20≤T≤750 w/exposed bonnet	Low-Moderate-High Temp	Std.	Std. Non-Asb.	Std. TFE	Std. LL	A
			-38V	Non-Asb. TFE	LL	B
-20≤T≤750	HighTemp -38HT	Non-Asb.	Std. Graphite	LL	G*	C

\* Positioner Required  
 LL = Live-Loaded.

TABLE 7

Positioners with ISO Namur Mounting						
I/P Positioner Model #9520R	CODE			P/P Positioner Model #9540R	CODE	
	With Airset	w/o Airset	With Airset		w/o Airset	
4-20 mA Direct	A	N	G	3-15 psig Direct	1	7
20-4 mA Reverse	B	P	H	15-3 psig Reverse	2	8
Split Rg. Direct 4-12 mA	C	T	J	Split Rg. Direct 3-9 psig	3	9
Split Rg. Direct 12-20 mA	D	U	K	Split Rg. Direct 9-15 psig	4	\$
Split Rg. Reverse 20-12 mA	E	@	L	Split Rg. Reverse 15-9 psig	5	&
Split Rg. Reverse 12-4 mA	F	Q	M	Split Rg. Reverse 9-3 psig	6	/

Use "98" coder sheet to select Smart I/P Positioner  
 Customer Supplied Positioner

When ordering a valve per one of Cashco's special dwgs, the Code "X" and the 5-digit number following override all other options. Otherwise, proceed with following.

TABLE 1

Size	Actuator	Fail Position	CODE	
			W/Handwheel STD.	NO Handwheel OPT-3
1"	48R-01, ATO, 5-15 psig	Close	1	B
	48D-01, ATC, 5-15 psig	Open	A	T
1-1/2"	48R-01, ATO, 5-15 psig	Close	G	D
	48D-01, ATC, 5-15 psig	Open	C	U
2"	48R-01, ATO, 5-15 psig	Close	2	F
	48D-01, ATC, 5-15 psig	Open	E	V
3"	148R-01, ATO, 5-13 psig	Close	3	J
	148D-01, ATC, 5-13 psig	Open	H	W
4"	148R-02, ATO, 10-26 psig	Close	M	P
	148D-02, ATC, 10-26 psig	Open	N	Z
6"	148R-02, ATO, 10-26 psig	Close	6	S
	148D-02, ATC, 10-26 psig	Open	R	7
8"	148R-02, ATO, 10-26 psig	Close	8	5
	148D-02, ATC, 10-26 psig	Open	&	9

TABLE 9

Positioner Accessories/Tubing				
TUBING				
CHARACTERISTIC	LINEAR	Std. Impolene	Copper	SST
		=%	—	CODE
√	—	G	1	4
—	√	H	2	5

TABLE 8

Option	Opt. No.	CODE
None	—	0
NACE	-40	N

TABLE 10

Proximity Limit Switches									
Mfg/Model	Type	No. Switches	Valve Plug	CODE	Mfg/Model	Type	No. Switches	Valve Plug	CODE
None	—	—	—	0	None	—	—	—	0
"GO" Series	Gen. Purpose	1	Open	1	73-13523 -A1	Hazardous Location Class I & II All Groups	1	Open	4
		1	Closed	2			1	Closed	5
73-13528 -A1		2	Open & Closed	3			2	Open & Closed	6

TABLE 11

Accessories	CODE
None (other than indicated on this Coder Sheet)	0
Valve Mounted Accessories-Any of the following: Pneumatic Position Bypass 3-way Solenoid Valve 764P Pressure Controller Extra Airset(s) I/P Transducer Lockup Valve	9
Travel Stop Screw	A
Travel Stop Screw plus "Code 9" Above	Z

\* Use of a "9" Code requires that a "99 Coder" Sheet be completed.

TABLE 12

Painting and Cleaning	Opt.	Std Commercial Cleaning	Cleaned to Spec. #S-1542	Cleaned to Spec. #S-1134* (O <sub>2</sub> Cleaned)
		CODE	CODE	CODE
Std/Commercial Epoxy	—	0	3	6
Epoxy-Basic Valve	-95	1	4	7
Epoxy-Basic Valve plus Accessories	-95	2	5	8

\* SST bodies only. Cleaned for oxygen service.