

# PREMIER EZO

## BUTTERFLY ROTARY CONTROL VALVE



FIGURE 1  
PREMIER EZO LINED BUTTERFLY  
CONTROL VALVE

The Premier EZO is an elastomer lined concentric butterfly control valve with a pneumatic spring-diaphragm actuator. The unique design feature of the Premier EZO is the geometrically formed elastomer liner that reduces seating and unseating torque levels, allowing E Z-er Opening, reducing annoying "pop-off" at opening.

An alternate design – Premier Unlined – is a seatless design that allows the disc 360 degree rotation, that has no elastomer liner and can be applied in higher temperature services where shutoff is not critical.

Both designs are for low-to-moderate pressure drop *throttling* applications. Installation is between piping flanges as a flangeless wafer. (**Note: Premier EZO must be installed between RF weldneck flanges.**)

## FEATURES

- Six sizes; 3" - 12" (DN80 - 300)
- Flangeless wafer body
- Three body materials
- Two elastomer liner materials
- Integral extended bonnet
- Heavy stem guides
- Low pressure actuator package designed for throttling

## APPLICATIONS

Primarily applied in non-critical utility applications such as compressed air or gas, cooling water, chilled water, hot water, or some HC services for Premier EZO.

Premier Unlined is primarily applied in steam and hot gas, including HC services.

## STANDARD/GENERAL SPECIFICATIONS

<b>Body Design Type:</b>	Concentric butterfly-type; 90° rotation. Flangeless wafer-type for mounting between pipe flanges.  <u>Premier EZO</u> – includes elastomer liner. <u>Premier Unlined</u> – no elastomer liner.	<b>Maximum Body Temperature:</b>	Function of body material and liner material.  <u>Premier EZO – Buna-N liner:</u> CI, CS, SST: +180°F (83°C) <u>Premier EZO – EPDM liner:</u> CI, CS, SST: +250°F (122°C)																								
<b>Body Sizes:</b>	3", 4", 6", 8", 10" and 12". (DN80, 100, 150, 200, 250 and 300.)	<b>Minimum Body Temperature:</b>	Function of liner material. <u>Premier EZO – Buna-N liner:</u> CI, CS, & SST : +10°F (-12°C) <u>Premier EZO – EPDM liner:</u> CI, CS, & SST: -20°F (-29°C)																								
<b>Body Materials:</b>	CI — Cast Iron. CS — Cast Steel SST — Cast 316 SST See Table 1 for material specifications.	<b>Flow Direction:</b>	Bi-directional; 0-90° rotation.																								
<b>Elastomer Liner Materials:</b>	Premier EZO ONLY. Backup ring – hard synthetic rubber. Seat and flange face – Buna-N (Nitrile), EPDM (Ethylene propylene).	<b>Inherent Characteristic:</b>	Equal Percentage.																								
<b>Body Pressure/Temperature Rating:</b>	See Table 1. Dependent on body material – CI – ANSI 125#. CS & SST – ANSI 150#/300#.	<b>Seat Leakage Class:</b>	Per ANSI/FCI 70-2 @ ΔP min ≥ 50 psid (3.45 Bard). <u>Premier EZO</u> – Class VI. <u>Premier Unlined</u> – Class I; i.e. 1% Max Cv.																								
<b>Body Face-To-Face Dimensions:</b>	Per MSS-SP67. See Figure 5 for dimensions.	<b>Rangeability:</b>	100:1																								
<b>Maximum Body Pressure:</b>	CI – per ANSI B16.1. CS & SST – per ANSI B16.34. See Table 1.  CI – 200 psig (13.8 Barg). CS – 740 psig (51.0 Barg). SST – 720 psig (49.6 Barg).	<b>Maximum Cv Capacity:</b>	<table border="1" style="width: 100%; border-collapse: collapse; text-align: center;"> <thead> <tr> <th style="text-align: left;">Body Size</th> <th colspan="2">Cv Capacity</th> </tr> <tr> <th style="text-align: left;">In. (mm)</th> <th>Premier EZO</th> <th>Premier Unlined</th> </tr> </thead> <tbody> <tr> <td>3" (DN80)</td> <td>179</td> <td>243</td> </tr> <tr> <td>4" (DN100)</td> <td>522</td> <td>670</td> </tr> <tr> <td>6" (DN150)</td> <td>1021</td> <td>1345</td> </tr> <tr> <td>8" (DN200)</td> <td>2590</td> <td>3459</td> </tr> <tr> <td>10" (DN250)</td> <td>3815</td> <td>4406</td> </tr> <tr> <td>12" (DN300)</td> <td>7810</td> <td>8455</td> </tr> </tbody> </table>	Body Size	Cv Capacity		In. (mm)	Premier EZO	Premier Unlined	3" (DN80)	179	243	4" (DN100)	522	670	6" (DN150)	1021	1345	8" (DN200)	2590	3459	10" (DN250)	3815	4406	12" (DN300)	7810	8455
Body Size	Cv Capacity																										
In. (mm)	Premier EZO	Premier Unlined																									
3" (DN80)	179	243																									
4" (DN100)	522	670																									
6" (DN150)	1021	1345																									
8" (DN200)	2590	3459																									
10" (DN250)	3815	4406																									
12" (DN300)	7810	8455																									
<b>Maximum Shutoff Pressure Drop:</b>	<u>Premier EZO</u> – 150 psid (10.3 Bard) <u>Premier Unlined</u> – Function of body size. Up to 300 psid (20.7 Bard). See Table 2.	<b>Clamping Companion Flanges:</b>	Premier EZO – CS or SST weldneck flanges ONLY, RF or FF, pressure classes 150# or 300#; <u>NO</u> CI 125# or 250# pipe flanges. <u>Premier Unlined</u> – CS or SST flanges, RF or FF, pressure classes 150# or 300#; CI 125# FF or 250# RF flanges.																								
<b>Maximum Dynamic Pressure Drop:</b>	Function of degrees rotation, actuator size, shaft material, body size, and internal velocity. See Table 3A&3B for limitations expressed as a pressure drop.	<b>Minimum Body Pressure:</b>	<u>Premier EZO</u> – Partial vacuum down to 0.5 psia (0.035 BarA). <u>Premier Unlined</u> – Full vacuum 0.0 psia (0.0 BarA).																								

Note: Metric Capacity Factor – Kv  
 Cv ≈ 1.16 x Kv

**Stem Diameter:**

Body Size In. (mm)	Stem Diameter In. (mm)
3"&4" (DN80&100)	0.625" (15.9)
6"-12" (DN150-300)	1.000" (25.4)

**Painting:**

Standard. All non-stainless steel portions of basic unit assembly painted with corrosion resistant epoxy paint per Cashco Spec #S-1606. No paint on tubing or tube fittings. Accessories — standard paint received from suppliers.

Optional. Two-step, extra thick epoxy coating; Opt-95.

**Flange Surface Finish:**

Premier EZO – Not applicable. **NO** pipe flange gaskets to be utilized.  
Premier Unlined – 250/125 micro-inch  $R_a$  (equivalent to 250/125 AARH). Suitable for use with spiral-wound metallic-filled gaskets.

## BODY SUB-ASSEMBLY MATERIAL SPECIFICATIONS

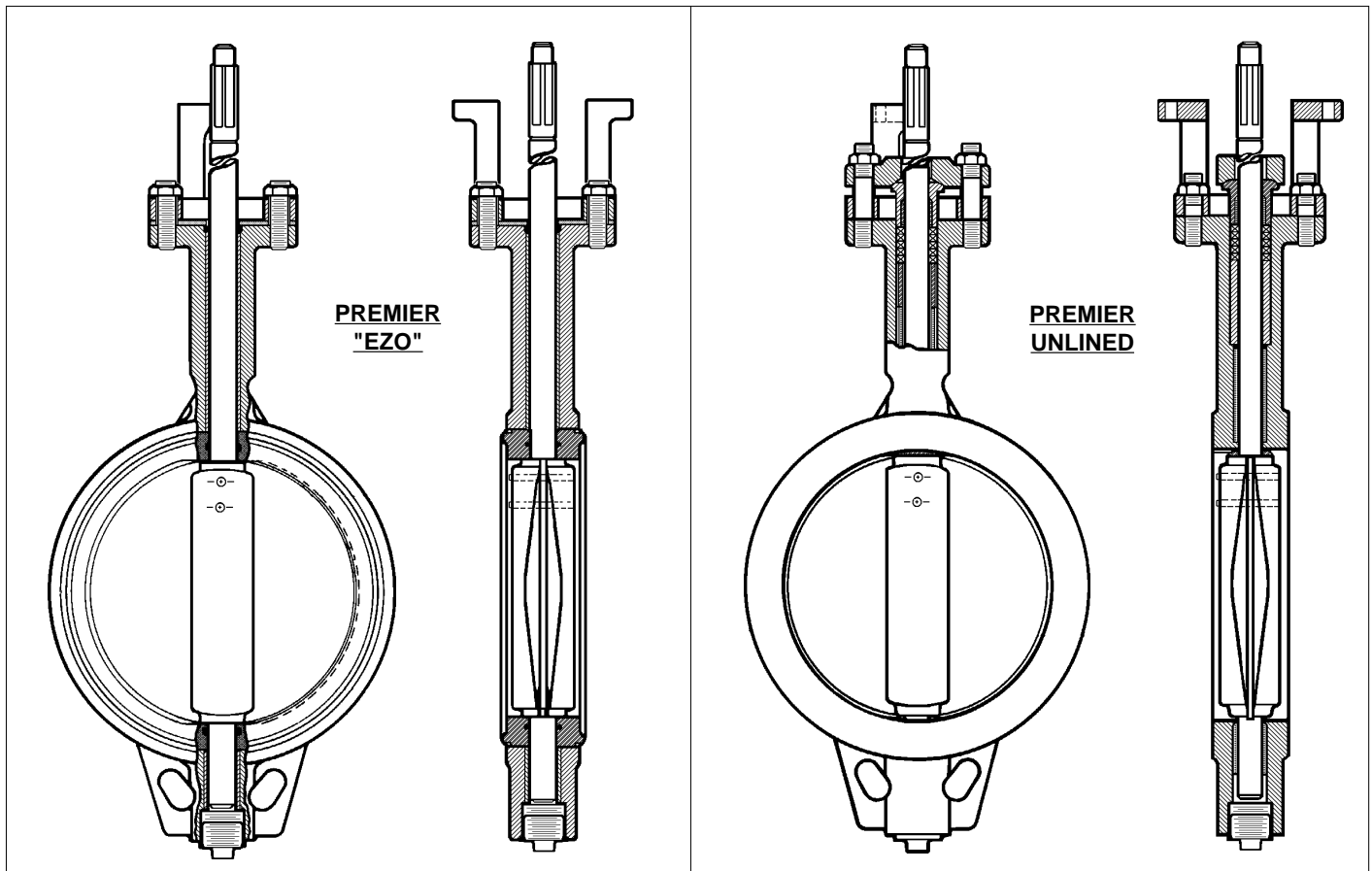

**FIGURE 2:** Premier Body Cross Sections

**Body:**

CI – ASTM A126, Class B  
 CS – ASTM A216, Gr. WCB  
 SST – ASTM A351, Gr. CF8M

Alternate: Body sizes 3" – 10" (DN80-250); ASTM A479, Gr.316 SST.  
 Body size 12" (DN300); ASTM A479, Gr.XM-19, Cond.HS, Nitronics 50HS.

**Body Plug:**

Similar to body material.

**Elastomer Liner & O-rings:**

Premier EZO ONLY;  
 Buna-N (Nitrile),  
 EPDM (Ethylene Propylene).

**Disc:**

ASTMA351, Gr. CF8M (cast 316 SST).

**Stem & Disc Pins:**

Standard: ASTM A564, Cond H1075 SST.

**Packing Follower:** Premier Unlined ONLY;  
303 SST with TFE tape-bushing.

**Packing:** Premier Unlined ONLY;  
Braided TFE, split-ring.

**Packing Flange:** Premier EZO;  
304 SST.

Premier Unlined;  
Body sizes 3" & 4" (DN80 & 100),  
304 SST.  
Body Sizes 6" - 12" (DN150 - 300),  
ductile iron.

**Upper Sleeve:** Premier Unlined ONLY;  
316 SST.

**Bearings:** Premier EZO;  
TFE-lined fiberglass.  
Premier Unlined;  
Stem – TFE-lined 316 SST,  
Thrust – TFE.

**Cap Screws, Studs & Nuts:** 18-8 SST.

**Yoke:** Body Sizes 3" & 4" (DN80 - 100),  
carbon steel structural tube.  
Body Sizes 6" - 12" (DN150 - 300),  
ductile iron.

### ACTUATOR TECHNICAL SPECIFICATIONS

**Basic Design:** 0-90° Rotary. Spring-diaphragm. Rolling diaphragm with multiple springs. Enclosed linkage. Field-reversible for "direct" or "reverse" action (see Fig. 3). Standard with manual handwheel operator.

#### Size, Stroke & Volume:

Basic Model No.	Nominal Diaphragm Area in <sup>2</sup> (cm <sup>2</sup> )	Lever Arm Length in (mm)	Nominal Stroke* in (mm)	Volumes	
				Clearance in <sup>3</sup> (cm <sup>3</sup> )	Volumetric in <sup>3</sup> (cm <sup>3</sup> )
48D 48R	48 (310)	1.375 (34.9)	1.94 (49.3)	27 (440)	87 (1425)
148D 148R 148XD 148XR	148 (955)	1.875 (47.6)	2.65 (67.3)	90 (1475)	372 (6095)

\* To generate 90° rotation

Action	Model No.	Body Size	Bench Setting Range
Direct; ATC-FO (Increase in air "LOAD" rotates valve stem CW, closing valve)	48D-01	3" & 4"* (DN80 & 100)	5-13 psig (0.34-0.90 Barg)
	148D-01	6"* (DN150)	5-13 psig (0.34-0.90 Barg)
	148D-03	8" (DN200)* Premier Unlined ONLY 10" & 12" (DN250 & 300)	7.5-19.5 psig (0.52-1.34 Barg)
		Premier EZO ONLY 10" (DN250)	
	148XD-01	Premier EZO ONLY 12" (DN300)	14-30 psig (0.97-2.07 Barg)
Reverse; ATO-FC (Increase in air "LOAD" rotates valve stem CCW, opening valve)	48R-01	3" & 4"* (DN80 & 100)	5-13 Psig (0.34-0.90 Barg)
	148R-01	6"* (DN150)	5-13 psig (0.34-0.90 Barg)
	148R-03	8" (DN200)* Premier Unlined ONLY 10" & 12" (DN250 & 300)	7.5-19.5 psig (0.52-1.34 Barg)
		Premier EZO ONLY 10" (DN250)	
	148XR-01	Premier EZO ONLY 12" (DN300)	14-30 psig (0.97-2.07 Barg)

\* Both Premier EZO & Premier Unlined

ATC-FO = Air-to-Close, Fail Open;  
ATO-FC = Air-to-Open, Fail Close.  
**NOTE:** No actuator bench setting range selection required; i.e. one actuator for each body size.

**Maximum Operating Supply Pressure:** 48 D/R = 20 psig (1.38 Barg).  
148 D/R = 36 psig (2.48 Barg).  
148X D/R = 44 psig (3.03 barg).

**Ambient Temperature Range:** -20° ≤ T<sub>amb</sub> ≤ 180°F.  
(-29° ≤ T<sub>amb</sub> ≤ 83°C).

**Mounting Positions:** May be rotated in two - 90° orientations for each "direct" or "reverse" arrangement. See Figure 5.

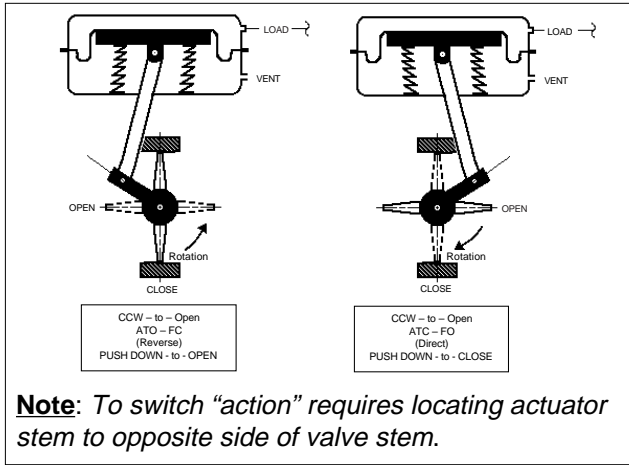

**Note:** To switch "action" requires locating actuator stem to opposite side of valve stem.

Figure 3: Plug vs. Lever Arm vs. Actuator Orientation

**Travel Stop Screw:** Standard – Limits travel to 0° – 90° rotational travel.  
Opt-61 – Allows adjustment of actuator stem “downwards” travel.

**Air Connection:** 1/4" female NPT.

**Stroking Time:** Reference STKSP-TB for stroke times with various accessories.

## ACTUATOR SUB-ASSEMBLY MATERIAL SPECIFICATIONS

**Casings & Diaphragm Plate:** Cast aluminum; ASTM B108, UNS 13560

**Springs:** Epoxy coated steel.

**Diaphragm:** Rolling-type; Buna-N with polyester fabric.

**Arm Housing:** Cast iron.

**Top-Case Plug:** Naval Brass

**Flange Bolting:** 18-8 SST.

**Turnbuckle Assembly:** Plated steel and SST.

**Travel Stop Screw & Jamnut:** Plated steel.

**Lever Arms:** SST with SST bolt and nut.

**Cam/Spacer:** SST.

**Nameplate:** SST.

**Option -3 :**

**Handwheel:** Cast Aluminum

**Handwheel Stem:** 316 SST.

**Handwheel Gland:** Naval brass.

**Locking Lever:** Plated malleable iron.

**Threadseal:** 18-8 SST with Buna-N insert.

**Position Indicator Assembly with 9000R P/P Positioner:** Plate – SST with high visibility red indicating zone displaying degree of valve “opening”.  
Housing – 48D/R – aluminum; 148D/R, 148XD/R – cast iron.  
Lens – plastic.  
Coverplate – SST.  
External screws – SST.  
Outboard stem bearing – steel ball bearing.  
**NOTE:** With 9520R or 9540R, the position indicator is integral with positioner, and housing is cast iron.

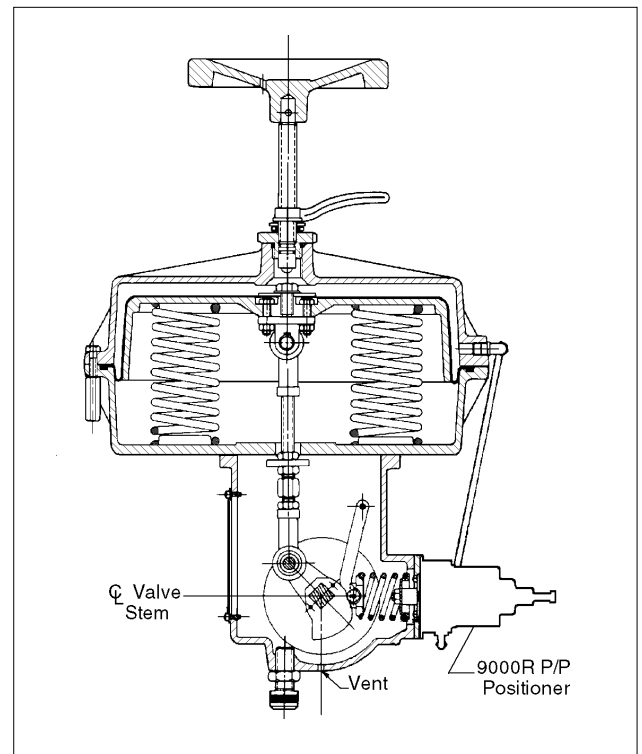

**Figure 4:** Model 148R actuator with 9000R P/P Positioner with Opt -3 Manual Handwheel Operator

## OPTION SPECIFICATIONS

**Option -3:** MANUAL HANDWHEEL OPERATOR. A handwheel and locking lever are supplied to allow manually over-riding the standard pneumatic actuator in an emergency.

**Option -61:** DOWN TRAVEL STOP – Extra-long down travelstop screw to limit stroke to approximately 0-60° rotation

## APPLICATION AND SELECTION

The following procedure will help determine a suitable selection for an application. Consult your Cashco area representative for assistance in sizing, selection, and noise prediction by computer.

- STEP 1. FIVE KNOWNS. The following minimal parameters/information must be available before a selection procedure can begin:
- a. Service Fluid — What is it? Liquid or gas? SG (std. cond.).
  - b. Inlet Pressure —  $P_1$  (upstream pressure).
  - c. Outlet Pressure —  $P_2$  (downstream pressure).
  - d. Desired capacity — Cv, GPM, SCFH; minimum, maximum and normal.
  - e. Fluid temperature —  $T_1$ , SG (actual).

Example: Max Cv Req'd = 580 Cv;  
 Min Cv Req'd = 128 Cv;  
 Reserve capacity – 30%  
 Max Cv Req'd =  
 $1.30 \times 580 \text{ Cv} = 754$   
 Select the body size and seal retainer nearest to the 754 Cv from Table 5.

Preliminary selections –

6" Premier EZO:  
 @ Cv = 754 – 71% travel;  
 @ Cv = 128 – 29% travel;  
 Max Cv Available – 1021Cv.

6" Premier Unlined:  
 @ Cv = 754 – 67% travel;  
 @ Cv = 128 – 27% travel;  
 Max Cv Available = 1345 Cv.

- STEP 2. P vs. T BODY RATINGS. Select a desired body material. For the desired body material ensure that the actual design inlet temperature/pressure limits established in Table 1 are not exceeded.

- STEP 3. PRESSURE DROP. Determine maximum pressure drop under flowing conditions and at shutoff conditions. Do not exceed the limits in Tables 2, 3A and 3B. (**Note:** *No actuator selection is required as only one size/bench set range exists for each body size and body design.*)

- STEP 7. RANGEABILITY. Check the Min. Cv of the selections of Step 6. Always attempt to keep the selection above 10% travel at Min. Cv.

6" Premier EZO – Rangeability = 100:1  
 Min Cv Available =  $1021 \text{ Cv}/100$   
 = 10.2 Cv

6" Premier Unlined – Rangeability = 100:1  
 Min Cv Available =  $1345 \text{ Cv}/100$   
 = 13.5 Cv

- STEP 4. CHARACTER and RESERVE. Decide whether a positioner will be utilized. If a linear character is desired, a positioner is required. If an equal % character is desired, a positioner is not necessarily required as both Premiers have an inherent equal % characteristic.

Both of the examples of Step 6 are suitable.

Decide the amount of over-capacity in the selection; i.e. equal % character with 25% reserve capacity. (**Note:** *A linear character gives "constant gain" throughout the full travel. An equal % character gives "low gain" up to near 50% of travel, a "medium gain" up to about 75% travel, and a "high gain" the last 25% of travel.*)

- STEP 8. NOISE PREDICTION. Determine if the predicted noise level exceeds required limits.

<u>Basic Design</u>	<u>Max SPL</u>
Premier EZO	90 dBA
Premier Unlined	95 dBA

- STEP 5. BODY DESIGN. Choose whether a Premier EZO or Premier Unlined should be applied. Fluid temperature and desired shutoff affect the choice of design.

If noise levels exceed the above limits, it may be necessary to use downstream dB plates.

- STEP 6. CAPACITY. Using the knowns from Steps 1 and 5, calculate the maximum and minimum Cv required.

- STEP 9. FAILURE ACTION. Consider the process related safety conditions to determine if the valve should "fail open" or "fail close" upon:
- a. loss of air supply pressure
  - b. loss of electric power\*

- c. loss of both supply air and electric power. \*  
\*Requires 3-way solenoid valve.

- STEP 12. ACCESSORIES. Consider use of various valve-installed accessories:
- a. P/P positioner (two choices)
  - b. I/P positioner
  - c. I/P transducer
  - d. Position limit switches
  - e. Position transmitter
  - f. Solenoid valve
  - g. Airset(s)
  - h. 764P/PD pressure controller.

STEP 10. OPTIONAL CONSTRUCTION. Reference Option Specifications section for recommended options for various fluid services.

STEP 11. TRIM MATERIALS. Reference Table 4 for suitability of the desired Trim Designation Number for corrosion.

### TECHNICAL SPECIFICATONS

GRAPH NO. 1 –  $F_L$  FACTORS  
PREMIER BUTTERFLY  
("EZO" OR UNLINED)

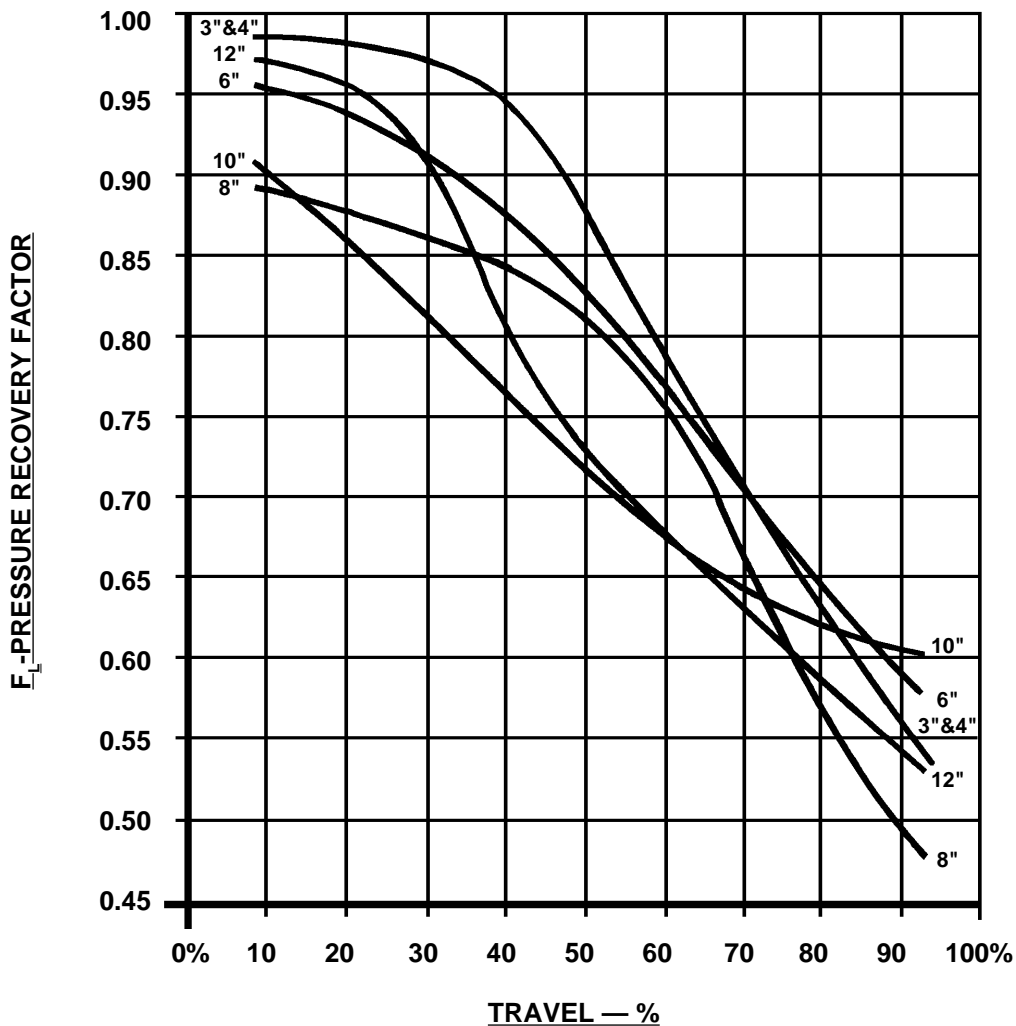

## MOUNTED ACCESSORY SPECIFICATIONS

**Positioners:** General. Mounted to arm housing. All feedback linkage is enclosed and not exposed directly to elements. Each positioner supplied with 2-gauge cluster; dual scale gauges. Pneumatic output load as required by actuator bench set range. Dedicated airset recommended.

**P/P Pneumatic.** Model 9000R. Accepts 3-15 psig (0.2-1.0 Barg); 2-way split ranges 3-9 or 9-15 psig (0.2-0.6, 0.6-1.0 Barg) input signals. Equal % or linear characterization cams (linear cam only for split range applications). Adjustable zero; fixed gain, stroke or damping. SIG and LOAD gauges. Side mounted to arm housing. Optional bypass. See technical bulletin 9000R-TB.

**P/P Pneumatic.** Model 9540R. Accepts 3-15 psig (0.2-1.0 Barg); 2-way split ranges 3-9 or 9-15 psig (0.2-0.6 or 0.6-1.0 Barg) input signals. Equal % or linear characterization cams. Adjustable zero, gain damping or stroke. SIG and LOAD gauges. Complete with position indicator. Enclosed gauge cluster. End of shaft mounting to arm housing. Bypass included. See technical bulletin 9540R-TB.

**I/P Electro-Pneumatic.** Model 9520R. Accepts 4-20 mA; 2-way split ranges 4-12 or 12-20mA input signals. Equal % or linear characterization cams. NEMA 3 enclosure, intrinsically safe, FM approved. Requires separate electronic "barrier" for proper installation. SUPPLY and LOAD gauges supplied on external gauge cluster block. Complete with position indicator. End of shaft mounting to arm housing. See technical bulletin 9520R-TB.

**Air Tubing:** Standard instrument air tubing is Imperial-Eastman "Impolene" thermoplastic tubing with brass fittings

Optional copper tubing with brass fittings, or SST tube and fittings.

Optional overpressure protection relief valve to prevent overpressurizing actuator and causing internal damage. Available in brass or SST.

**Airset:** Model 5100P instrument air supply regulator. Use with positioners. Bracket mounted to actuator casings. Supplied with gauge for P/P positioners; no gauge with I/P positioner. See technical bulletin 5100P-TB.

**Solenoid Valve:** Standard Brass: Available in standard weather-proof model or explosion-proof model. Brass body, 1/4" female NPT connections. Nipple mounted to actuator casing. 120 VAC, 60 Hz power supply.

Gen. Purpose: ASCO #8320G176.  
X-Proof: ASCO #EF8320G176.

Alternate SST: Similar to standard brass unit, except with 303 SST body.

Gen. Purpose: ASCO #8320G201.  
X-Proof: ASCO #EF8320G201.

Standard installation vents actuator and drives valve to fail-safe position upon loss of electrical power.

Consult factory for 230/1/50, 125 VDC power supplies, or intrinsically safe (IS) service.

**Position Indicating Switches:** With 9000R P/P Positioner. Proximity Controls Model 12ADO Mark I. Rotary trip switch. Mounted to end of shaft; direct drive. Includes 2-SPDT switches. Factory calibrated for "full open" and "full closed" positions. Aluminum enclosure. Explosion-proof.

Without Positioner. Same as with 9000R P/P positioner.

With 9520R I/P Positioner. Go Systems Series 70, Proximity probe-type, magnetic switches. Each probe contains 1-SPDT switch. Explosion-proof. 18-8 SST enclosure.

With 9540R P/P Positioner. Same as with 9520R I/P positioner.

**Other Accessories:** Bypass for 9000R P/P positioner.  
764P/PD pressure controller.  
I/P transducer.  
Lockup valve.  
Positioner transmitter.  
"Smart" positioner.

**TABLE 1**

**MATERIAL PRESSURE/TEMPERATURE RATINGS**

Body/Bonnet Materials		End Connection	English Units		Metric Units	
			Pressure (psig)	Temperature (°F)	Pressure (Barg)	Temperature (°C)
Cast Iron (CI)	A126, Class B	125#, 150#, 250# or 300# Flanged	200	-20 to +150	13.8	-29 to + 66
			190	200	13.1	94
			175	250	12.1	121
			165	300	11.4	149
			140	400	9.7	205
			125	450	8.6	232
Cast Carbon Steel (CS)	A216, Grade WCB	150#Flanged (PN20)	285	-20 to +100	19.7	-29 to + 38
			260	200	17.9	94
			230	300	15.8	149
			200	400	13.8	205
			170	500	11.7	260
		300#Flanged (PN50)	740	-20 to + 100	51.0	-29 to +38
			675	200	46.6	94
			655	300	45.2	149
			635	400	43.8	205
			600	500	41.4	260
Cast Stainless Steel (SST)	A351, Gr.CF8M	150#Flanged (PN20)	275	-20 to +100	19.0	-29 to +38
			235	200	16.2	94
			215	300	14.8	149
			195	400	13.5	205
			180	450	12.4	233
			170	500	11.8	260
		300#Flanged (PN50)	720	-20 to +100	50.0	-29 to +38
			620	200	42.8	94
			560	300	38.7	149
			515	400	35.6	205
			495	450	34.1	233
			480	500	33.1	260

**TABLE 2**

**MAXIMUM SHUTOFF PRESSURE DROP**

Premier Design	Body Size in. (mm)	Max Shutoff psid	Pressure (Bard)
EZO	ALL	150	(10.3)
Unlined	3"-8" (DN80-200)	300	(20.7)
	10" (DN250)	200	(13.8)
	12" (DN300)	175	(12.0)

TABLE 3A

**PREMIER “EZO” MAXIMUM DYNAMIC PRESSURE DROP**

Actuator		Body Size in/(mm)	Trim Design. No.	Maximum Dynamic Pressure Drop - psid(Bard)										
Action	Model No.			Travel – %										
				0%	10%	20%	30%	40%	50%	60%	70%	80%	90%	100%
Direct ATC-FO	48D-01	3" (DN80)	All	150 (10.3)	150 (10.3)	150 (10.3)	148 (10.2)	98 (6.8)	64 (4.4)	40 (2.8)	24 (1.7)	15 (1.1)	14 (1.0)	14 (1.0)
		4" (DN100)	All	150 (10.3)	150 (10.3)	100 (6.9)	66 (4.6)	43 (3.0)	28 (1.9)	17 (1.2)	10 (0.7)	6.5 (0.4)	6.0 (0.4)	6.0 (0.4)
	148D-01	6" (DN150)	All	150 (10.3)	150 (10.3)	150 (10.3)	132 (9.1)	86 (5.9)	56 (3.9)	35 (2.4)	21 (1.4)	13 (0.9)	12 (0.8)	12 (0.8)
	148D-03	8" (DN200)	All	150 (10.3)	150 (10.3)	150 (10.3)	98 (6.8)	64 (4.4)	41 (2.8)	25 (1.7)	15 (1.1)	9.3 (0.6)	8.5 (0.6)	8.5 (0.6)
	148D-02	10" (DN250)	All	150 (10.3)	118 (8.1)	81 (5.6)	52 (3.6)	33 (2.3)	21 (1.4)	13 (0.9)	7.6 (0.5)	4.8 (0.3)	4.4 (0.3)	4.4 (0.3)
	148XD-01	12" (DN300)	BL1 or BL2	150 (10.3)	146 (10.0)	100 (6.9)	63 (4.3)	40 (2.8)	25 (1.7)	15 (1.1)	9 (0.6)	5.7 (0.4)	5.2 (0.4)	5.2 (0.4)
			BL3 or BL4	150 (10.3)	139 (9.6)	95 (6.6)	60 (4.1)	38 (2.6)	24 (1.7)	15 (1.1)	8.6 (0.6)	5.4 (0.4)	4.9 (0.3)	4.9 (0.3)
Reverse ATO-FC	48R-01	3" (DN80)	All	150 (10.3)	150 (10.3)	150 (10.3)	150 (10.3)	150 (10.3)	120 (8.3)	75 (5.2)	45 (3.1)	28 (1.9)	26 (1.8)	26 (1.8)
		4" (DN100)	All	150 (10.3)	140 (9.7)	140 (9.7)	123 (8.5)	81 (5.6)	52 (3.6)	32 (2.2)	19 (1.3)	12 (0.8)	11 (0.8)	11 (0.8)
	148R-01	6" (DN150)	All	150 (10.3)	150 (10.3)	150 (10.3)	150 (10.3)	133 (9.2)	86 (5.9)	54 (3.7)	32 (2.2)	20 (1.4)	18 (1.2)	18 (1.2)
	148R-03	8" (DN200)	All	150 (10.3)	150 (10.3)	150 (10.3)	98 (6.8)	64 (4.4)	41 (2.8)	25 (1.7)	15 (1.1)	9.3 (0.6)	8.5 (0.6)	8.5 (0.6)
	148R-02	10" (DN250)	All	150 (10.3)	118 (8.1)	81 (5.6)	52 (3.6)	33 (2.3)	21 (1.4)	13 (0.9)	7.6 (0.5)	4.8 (0.3)	4.4 (0.3)	4.4 (0.3)
	148XR-01	12" (DN300)	BL1 or BL2	150 (10.3)	146 (10.0)	100 (6.9)	63 (4.3)	40 (2.8)	25 (1.7)	15 (1.1)	9 (0.6)	5.7 (0.4)	5.2 (0.4)	5.2 (0.4)
			BL3 or BL4	150 (10.3)	139 (9.6)	95 (6.6)	60 (4.1)	38 (2.6)	24 (1.7)	15 (1.1)	8.6 (0.6)	5.4 (0.4)	4.9 (0.3)	4.9 (0.3)

**TABLE 3B**

**PREMIER “UNLINED” MAXIMUM DYNAMIC PRESSURE DROP**

Actuator		Body Size in/(mm)	Trim Design. No.	Maximum Dynamic Pressure Drop - psid(Bard)										
Action	Model No.			Travel-%										
				0%	10%	20%	30%	40%	50%	60%	70%	80%	90%	100%
Direct ATC-FO	48D-01	3" (DN80)	All	300 (20.7)	300 (20.7)	300 (20.7)	300 (20.7)	231 (15.9)	142 (9.8)	86 (5.9)	50 (3.4)	29 (2.0)	22 (1.5)	22 (1.5)
		4" (DN100)	All	300 (20.7)	300 (20.7)	300 (20.7)	161 (11.1)	103 (7.1)	62 (4.3)	37 (2.6)	22 (1.5)	12 (0.8)	9.5 (0.7)	9.5 (0.7)
	148D-01	6" (DN150)	All	300 (20.7)	300 (20.7)	300 (20.7)	227 (15.7)	146 (10.1)	89 (6.1)	53 (3.7)	31 (2.1)	17 (1.2)	14 (1.0)	14 (1.0)
	148D-03	8" (DN200)	All	300 (20.7)	300 (20.7)	242 (16.7)	160 (11.0)	101 (7.0)	60 (4.1)	35 (2.4)	21 (1.4)	12 (0.8)	9.0 (0.6)	9.0 (0.6)
		10" (DN250)	All	200 (13.8)	198 (13.7)	132 (9.1)	86 (5.9)	53 (3.7)	32 (2.2)	18 (1.2)	11 (0.8)	6.0 (0.4)	4.6 (0.3)	4.6 (0.3)
		12" (DN300)	All	175 (12.1)	123 (8.5)	80 (5.5)	51 (3.5)	32 (2.2)	19 (1.3)	11 (0.8)	6.2 (0.4)	3.5 (0.2)	2.7 (0.2)	2.7 (0.2)
Reverse ATO-FC	48R-01	3" (DN80)	All	300 (20.7)	300 (20.7)	300 (20.7)	300 (20.7)	300 (20.7)	214 (14.8)	129 (8.9)	76 (5.2)	43 (3.0)	34 (2.3)	34 (2.3)
		4" (DN100)	All	300 (20.7)	300 (20.7)	258 (17.8)	238 (16.4)	156 (10.8)	94 (6.5)	56 (3.9)	32 (2.2)	18 (1.2)	14 (1.0)	14 (1.0)
	148R-01	6" (DN150)	All	300 (20.7)	300 (20.7)	300 (20.7)	300 (20.7)	212 (14.6)	128 (8.8)	76 (5.2)	44 (3.0)	25 (1.7)	20 (1.4)	20 (1.4)
	148R-03	8" (DN200)	All	300 (20.7)	300 (20.7)	242 (16.7)	160 (11.0)	101 (7.0)	60 (4.1)	35 (2.4)	21 (1.4)	12 (0.8)	9.0 (0.6)	9.0 (0.6)
		10" (DN250)	All	200 (13.8)	198 (13.7)	132 (9.1)	86 (5.9)	53 (3.7)	32 (2.2)	18 (1.2)	11 (0.8)	6.0 (0.4)	4.6 (0.3)	4.6 (0.3)
		12" (DN300)	All	175 (12.1)	123 (8.5)	80 (5.5)	51 (3.5)	32 (2.2)	19 (1.3)	11 (0.8)	6.2 (0.4)	3.5 (0.2)	2.7 (0.2)	2.7 (0.2)

**TABLE 4**

**TRIM DESIGNATION NOS. VS TRIM MATERIALS**

Premier Design	Part Description	Trim Designation Nos.			
		BL1	BL2	BL3	BL4
EZO (LINED)	ELASTOMER LINER	BUNA-N	EPDM	BUNA-N	EPDM
	O-RINGS	BUNA-N	EPDM	BUNA-N	EPDM
	STEM-SHAFT	17-4PH	17-4PH	*	*
	DISC	CF8M	CF8M	CF8M	CF8M
	DISC-to-SHAFT PINS	17-4PH	17-4PH	*	*
	SHAFT BEARINGS	TFE+Fbgls	TFE+Fbgls	TFE+Fbgls	TFE+Fbgls

\* 3"-10" (DN80-250), 316 SST; 12" (DN300), Nitronics 50HS.

Premier Design	Part Description	Trim Designation Nos.	
		BL8	BL9
(UNLINED)	STEM-SHAFT	17-4PH	*
	DISC	CF8M	CF8M
	DISC-to-SHAFT PINS	17-4PH	*
	THRUST BEARING	TFE	TFE
	SHAFT BEARINGS	TFE+316 SST	TFE+316 SST
	UPPER SLEEVE	316 SST	316 SST

\* 3"-10" (DN80-250), 316 SST; 12" (DN300), Nitronics 50HS.

**TABLE 5**

**FLOW COEFFICIENTS — CV**

Premier Design	Body Size in (mm)	Travel – %										
		0%	10%	20%	30%	40%	50%	60%	70%	80%	90%	100%
EZO (Lined)	3" (DN80)	0	1.8	6.3	15	30	48	66	83	113	159	179
	4" (DN100)	0	7.8	18	39	76	125	193	297	396	482	522
	6" (DN150)	0	26	66	138	230	352	511	725	934	1016	1021
	8" (DN200)	0	65	162	298	440	648	971	1399	1969	2461	2590
	10" (DN250)	0	19	191	381	629	954	1411	1984	2785	3529	3815
	12" (DN300)	0	117	273	508	659	1250	1913	2812	4139	6209	7810
Premier Design	Body Size in (mm)	Travel – %										
Unlined	3" (DN80)	2.4	4.9	11	22	39	62	90	138	198	234	243
	4" (DN100)	6.7	6.7	20	37	64	107	171	268	429	580	670
	6" (DN150)	13	20	54	114	209	336	552	848	1164	1312	1345
	8" (DN200)	35	35	61	156	294	519	848	1315	2093	3027	3459
	10" (DN250)	44	44	132	264	485	793	1322	2027	2996	3966	4406
	12" (DN300)	85	85	127	317	592	1015	1691	2790	4524	7018	8455

**FIGURE 5  
ACTUATOR MOUNTING POSITIONS – 9000R**

Position "A" is standard for fail closed action. Position "B" is standard for fail open action.  
Position "C" and "D" covers vertical piping.

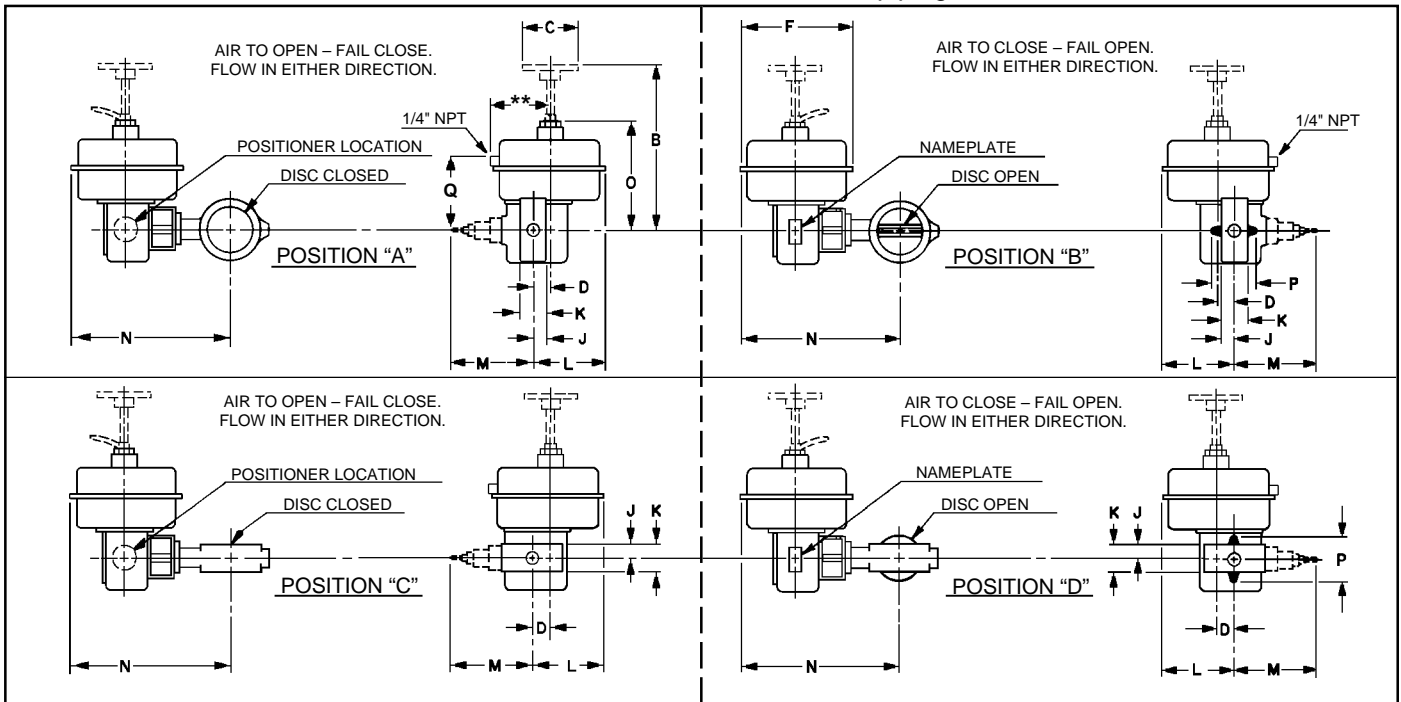

Dimensions in inches  $\pm 0.06"$  for 3", 4" and 6" valves.  $\pm 0.13"$  for 8", 10" and 12" valves.

Body Size	DIMENSIONS – ENGLISH UNITS - in. & lbs												WT. LBS.
	B	C	D	F**	J	K	L	M	N	O	P	Q	
3"	16.19	4.00	1.19	10.50	0.90	1.81	6.44	9.50	16.62	11.50	2.99	7.69	39
4"	16.19	4.00	1.19	10.50	1.03	2.06	6.44	9.50	16.62	11.50	3.99	7.69	57
6"	21.62	8.00	1.62	16.37	1.09	2.19	8.81	9.50	23.75	14.50	5.98	10.00	102
8"	21.62	8.00	1.62	16.37	1.19	2.38	9.81	9.50	24.75	14.50	7.98	10.00	119
10"	21.62	8.00	1.62	16.37	1.34	2.69	9.81	9.50	27.81	14.50	9.97	10.00	145
12"*	24.06	8.00	1.62	16.37	1.53	3.06	9.81	9.50	28.81	16.94	11.97	12.44	207

\*On 12" Unlined Deduct 2.44" from "B", "O" and "Q" dimensions.

\*\*Divide "F" measurement in half for 1/4" NPT Connection dimension.

Dimension in millimeters  $\pm 1.5$  mm for 80,100 and 150 valves  $\pm 3.3$ mm for 200, 250 and 300 valves.

ISO (DN)	DIMENSIONS – METRIC UNITS - mm & kg												WT. KG.
	B	C	D	F**	J	K	L	M	N	O	P	Q	
80	411	102	30.2	267	22.9	46.0	164	241	422	292	76.0	195	17.7
100	411	102	30.2	267	26.2	52.3	164	241	422	292	101	195	18.6
150	549	203	41.1	416	27.7	55.6	249	241	603	368	152	254	46.3
200	549	203	41.1	416	30.2	60.5	249	241	629	368	203	254	54.0
250	549	203	41.1	416	34.0	68.3	249	241	706	368	253	254	65.8
300*	611	203	41.1	416	38.9	77.7	249	241	732	430	304	316	93.9

\*On DN 300 Unlined 62mm from "B", "O" and "Q" dimensions.

\*\*Divide "F" measurement in half for 1/4" NPT Connection dimension.

**FIGURE 6  
ACTUATOR MOUNTING POSITIONS – 9520R/9540R**

Position "A" is standard for fail closed action. Position "B" is standard for fail open action.  
Position "C" and "D" covers vertical piping.

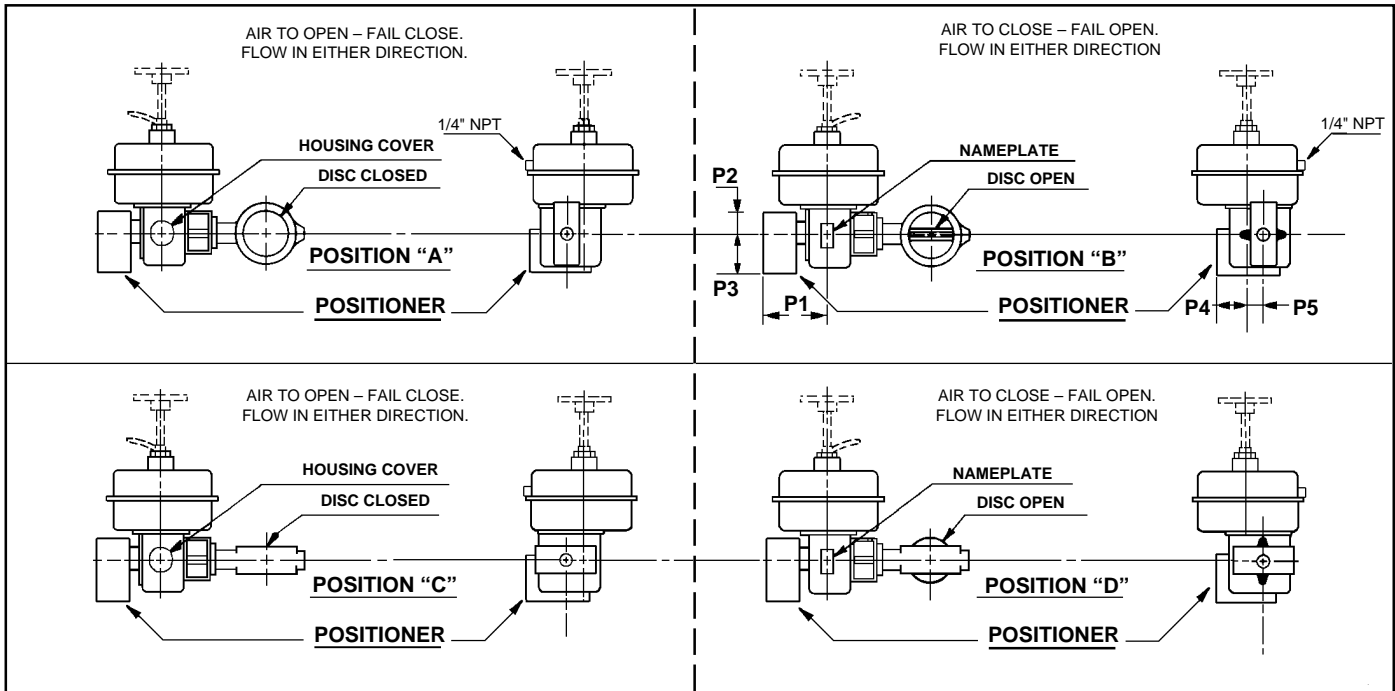

**Note:** All basic valve dimensions are indicated in Figure 5.

DIMENSIONS – ENGLISH UNITS - in. & lbs.												
	9520R I/P Positioner						9540R P/P Positioner					
Body Size - in.	P1	P2	P3	P4	P5	Wt. - lbs. *	P1	P2	P3	P4	P5	Wt. - lbs. *
3", 4"	8.75	1.75	4.81	6.12	1.94	5.5	8.06	1.75	3.69	4.88	1.99	3.5
6", 8", 10", 12"	9.00	1.75	4.81	6.12	1.94	5.5	8.31	1.75	3.69	4.88	1.94	3.5
DIMENSIONS – METRIC UNITS - mm & kg												
	9520R I/P Positioner						9540R P/P Positioner					
Body Size - DN	P1	P2	P3	P4	P5	Wt. - kg. *	P1	P2	P3	P4	P5	Wt. - kg. *
80, 100	222	44	122	155	50	2.5	205	44	94	124	50	1.5
150, 200, 250, 300	229	44	122	155	50	2.5	211	44	94	124	50	1.5

\* Add to weight of basic valve

# PRODUCT CODE 10/01/97

TABLE 3

BODY	SIZES	STEM & PINS	PREMIER EZO (Lined)				PREMIER UNLINED	
			BUNA-N		EPDM			
			TDN*	CODE	TDN*	CODE	TDN*	CODE
CI	All	17-4PH SST	BL1	1	BL2	4	BL8	7
	3"-10"	316 SST	BL3	A	BL4	D	BL9	G
CS	All	17-4PH SST	BL1	2	BL2	5	BL8	8
	3"-10"	316 SST	BL3	B	BL4	E	BL9	H
SST	All	17-4PH SST	BL1	3	BL2	6	BL8	9
	3"-10"	316 SST	BL3	C	BL4	F	BL9	J
	12"	Nitronic 50 HS	BL3	M	BL4	U	BL9	T

\*TDN – Trim Designation Number

TABLE 2

SIZE	LINED OR UNLINED	ACTUATOR	Fail Position	HANDWHEEL	
				W/O	WITH
				CODE	CODE
3"	Both	Model, Action, Bench			
		48R-01 ATO, 5-13 psig	Closed	1	G
4"	Both	48D-01 ATC, 5-13 psig	Open	9	W
		48R-01 ATO, 5-13 psig	Closed	2	H
6"	Both	48D-01 ATC, 5-13 psig	Open	V	R
		148R-01 ATO, 5-13 psig	Closed	3	J
8"	Both	148D-01 ATC, 5-13 psig	Open	A	S
		148R-03 ATO, 7.5-19.5 psig	Closed	4	K
10"	Lined (EZO)	148D-03 ATC, 7.5-19.5 psig	Open	B	T
		148R-02 ATO, 10-26 psig	Closed	7	N
12"	Lined (EZO)	148D-02 ATC, 10-26 psig	Open	E	Y
		148XR-01 ATO, 14-30 psig	Closed	8	P
10"	Unlined	148XD-01 ATC, 14-30 psig	Open	F	Z
		148R-03 ATO, 7.5-19.5 psig	Closed	5	L
12"	Unlined	148D-03 ATC, 7.5-19.5 psig	Open	C	U
		148R-03 ATO, 7.5-19.5 psig	Closed	6	M
		148D-03 ATC, 7.5-19.5 psig	Open	D	Q

Size/Actuator Selection

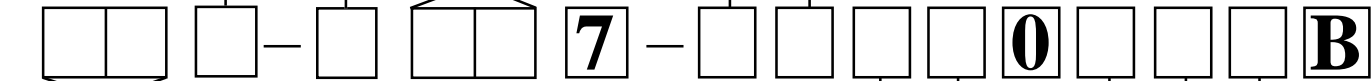

PRODUCT	CODE
PREMIER "EZO" LINED BUTTERFLY CONTROL VALVE	PR
PREMIER UNLINED BUTTERFLY CONTROL VALVE	PU

TABLE 1

**NOTE: Connection flgs. must be weld neck type for Lined Valve.**

When ordering a valve per one of Cashco's special dwgs, the code "X" and the 5-digit number following override all other options. Otherwise, proceed with following.

SPECIAL CONSTRUCTION						CODE
						X
POSITIONER ACCESSORIES						
TYPE OF POSITIONER	GAUGES	CHARACTERISTIC*		TUBING		
		=%	LINEAR	Std. Impolene	SST	Copper
NONE	—	—	—	CODE	CODE	CODE
Pneumatic 9000R	√	√	—	0	0	0
	√	—	√	D	A	7
	—	√	—	E	B	8
	—	—	√	G	4	1
	—	—	√	H	5	2

\*For Split Range Service, P/P's ONLY supplied with linear characteristic cams.

TABLE 8

Position Limit Switches *				OR	Position X-Mitter W/Limit Switches *				
Mfg./Model	Type	No. SPDT Swtchs/Unit	Trip Position	CODE	Mfg./Model	Type	No. SPDT Swtchs/Unit	Trip Position	CODE
None	—	—	—	0	None	—	—	—	0
Proximity Controls #12ADO	Rotary Trip X-proof	2	Full Open & Closed	B	Proximity Controls #15VDO	Proximity w/end of Travel Limit Switches X-Proof, 4-20mA	2	Full Open & Closed	C

\* NOT AVAILABLE when I/P Positioner is mounted.  
Premier-TB

@PCM

TABLE 4

PACKING			
LINED No Packing	CODE	UNLINED	CODE
	00	Standard: TFE	10
		Oxygen: TFE	20

Packing

TABLE 5

PIPE POSITION	MOUNTING POSITION	ACTUATOR ACTION	CODE
Horizontal	A	ATO	A
	B	ATC	B
Vertical	C	ATO	C
	D	ATC	D

Mounting Position

TABLE 6

P/P Positioner	CODE	
None	O	
No Positioner, with P/P Linkage	N	
P/P- Pneumatic Model #9000R	CODE w/Airset	CODE w/o Airset
Direct 3-15 psig	1	R
Reverse 15-3 psig	2	S
Direct 6-30 psig	3	T
Reverse 30-6 psig	4	U
Direct Split Range 3-9 psig	5	V
Direct Split Range 9-15 psig	6	W
Reverse Split Range 15-9 psig	7	Y
Reverse Split Range 9-3 psig	8	Z

NOTE: Airset supplied w/gauge. Select range in Table 10.

Positioner

TABLE 9

Airset Range	CODE
No Airset	0
5-13 Bench Set (0-30 psig range)	A
7.5-19.5 Bench Set (0-60 psig range)	B

TABLE 10

Accessories	CODE
None (other than indicated on this Coder Sheet)	0
Valve Mounted Accessories - Any of the following: Pneumatic Posit. Bypass 3-way Solenoid Valve 764P Press. Controller Extra Airset(s) I/P Transducer Lockup Valve	9
Travel Stop Screw	A
Travel Stop Screw plus "Code 9" Above	Z

Accessories

Limit Switches/Transmitters

\* Use of a "9" Code requires that a "99 Coder" Sheet be completed.

TABLE 11

Painting	CODE
Standard	0
Epoxy-Basic Valve	1
Epoxy-Basic Valve plus Accessories	2

Painting

