



Model 989
1" – Body Size
CF3M Body – 300# Flanged
Model 55R Actuator
(ATO-FC Action)
"Short Pattern"

MODEL 989

Pneumatic Control Valve for General and Chemical Service

The Model 989 is a globe-style, pneumatic control valve designed primarily for general and chemical service. The valve's body/trim materials are available in WCB/316L SST or CF3M/316L SST constructions.

Standard trim is metal seated design giving Class IV shutoff. Optional composition seat design gives Class VI shutoff. Available in body sizes 1" thru 2" (DN25–DN50) with flanged end connections.

FEATURES

- All wetted trim components of 316L SST.
- Standard non-asbestos construction.
- Dual stem guiding...
 - improved shutoff,
 - increased packing life,
 - maximized stability.
- Standard internally live-loaded V-ring packing.
- Multiple packing designs to meet reduced **fugitive emission** levels.
- Flow-to-open design for increased...
 - rangeability,
 - stability.
- Quick change trim.
- High pressure drop capability, up to 740 psid (51.0 Bard).
- Multiple reduced trim selections.
- Equal percent or linear characterization.
- External corrosion protection.
- Face-to-Face dimensions per ISA S75.03 ("Short Pattern").

APPLICATIONS

Designed as a general service control valve for utilities services—steam, air, oil, water, industrial gases, etc. Also suitable for many chemical services where WCB or CF3M are acceptable materials. The minimum seat/plug/stem material is 316L SST to maximize corrosion resistance. May be applied up to 740 psig (51 Barg) pressure limit, or 450°F (232°C) temperature limit as a standard unit; up to 750°F (400°C) with optional high-temperature construction.

STANDARD / GENERAL SPECIFICATIONS

- Body Sizes:** 1", 1-1/2" and 2".
(DN25, 40, and 50).
- Body Pressure Temperature Rating:** Meets ANSI B16.34 for 150# or 300# Pressure Classes for cast carbon steel (CS), cast stainless steel (SST). See Table 1.
- Max. Inlet Pressure:** CS – Up to 740 psig (51 Barg).
SST – Up to 720 psig (49.6 Barg).
(Refer to Model 988 for Hast-C materials.)
- Working Temperature Range:** Standard, all materials: -20°F to +450°F (-29°C to +232°C).
Optional, all materials: -20°F to +750°F (-29°C to +400°C).
- End Connections:** Flanged Only – All sizes and body materials. Separable Type; standard is CS flanges and CS split rings, optional SST. 150# RF and 300# RF: Mating dimensions in accordance with ANSI B16.5. F-to-F dimensions per ISA S75.03 - 1984.
NOTE: For NPT or SW end connections, apply a Model 988.
- Max. Pressure Drop:** Metal Seated – Up to 600 psid (41.4 Bard) for Full, 1-Step and 2-Step reduced ports. Up to 740 psid (51.0 Bard) for 3-Step, 4-Step, 5-Step and 6-Step reduced ports. TFE Soft Seated – Up to 400 psid (27.6 Bard).
See Tables 2 through 5.
- Seat Leakage:** Meets ANSI/FCI 70-2 (Rev. 1982). Standard – Metal Seated – Class IV. Optional – TFE Soft Seated – Class VI, with metal-to-metal backup.
- Flow Direction:** Standard: Flow-to-Open (FTO). Minimizes packing sealing pressure level. (Not recommended for Flow-to-Close direction.)

Rangeability:

Body Size inch (mm)	Port Size			FULL
	Reduced			
	3, 4, 5, & 6-Step	2-Step	1-Step	
1" (DN25)	25:1	35:1	50:1	
1-1/2" (DN40)	–	–	50:1	
2" (DN50)	–	–	50:1	

Inherent Flow Characteristic: Equal Percent or Linear; FTO direction only.

Flow Capacity: Per ISA 75.11 Standard. See Tables 7 and 8.

Body inch (mm)	Port - Orifice		Cv Max.	
	Description	Size inch (mm)	=%	Lin.
1" (DN25)	Full	.750" (19.0)	11.8	12.7
	1-Step Reduced	.562" (14.3)	7.0	7.5
	2-Step Reduced	.562" (14.3)	4.1	4.3
	3-Step Reduced	.332" (8.4)	2.5	2.5
	4-Step Reduced	.205" (5.2)	–	1.0
	5-Step Reduced	.155" (3.9)	–	0.50
1-1/2" (DN40)	Full	1.250" (31.8)	26	27
	Reduced	.750" (19.0)	10.4	10.8
2" (DN50)	Full	1.688" (42.9)	47	50
	Reduced	1.000" (25.4)	18.2	19.4

Actuators: Spring-Diaphragm Type. Select "direct" or "reverse" action; non-field reversible.

Action	Model	Body Sizes Used On inch (mm)	
Direct; ATC-FO (Increase in air "LOAD" extends actuator stem.)	55D	1", 1-1/2"	(DN25, 40)
	75D	1-1/2", 2"	(DN40, 50)
	115D	2"	(DN50)
Reverse; ATO-FC (Increase in air "LOAD" retracts actuator stem.)	55R	1", 1-1/2"	(DN25, 40)
	75R	1-1/2", 2"	(DN40, 50)
	115R	2"	(DN50)

ATC-FO = Air-to-Close, Fail Open;
ATO-FC = Air-to-Open, Fail Close.

See Tables 2 through 5 for proper selection of required bench setting range spring and Model number.

Painting:

Standard – All non-SST portions painted with corrosion resistant epoxy paint per Cashco Specification #S-1606 except tubing and fittings.
Optional – 2-coat epoxy coating per Cashco Specification #S-1547.

BODY SUB-ASSEMBLY SPECIFICATIONS

Body/Bonnet Materials: CS – ASTM A216, Gr. WCB.
SST – ASTM A351, Gr. CF3M (316L).

Separable Flange Materials: Standard: All body materials;
Flanges – CS per ASTM A216, Gr. WCB, or equal;
Split Rings – CS.
Optional: SST body materials;
Flanges – SST per ASTM A351, Gr. CF3M, or equal;
Split Rings – 316 SST.
Optional: All body materials;
Flanges – CS per above;
Split Rings – 316 SST.

Trim: Function of packing design.

Seat Design	Trim Designation #	Basic Trim Description
Metal	S1S, S1R, S1SE, S1RE	316L SST
	S40, S40E	NACE
	S1HT	High Temp
Composition Soft	S3S, S3R, S3SE, S3RE	316L SST/TFE
	S40T, S40TE	NACE/TFE

See Table 6 for complete trim material specifications.

Gaskets: Standard – Non-asbestos, Spiral-Wound Type ; 316L SST with carbon filler.

Stem Size: 0.625" (15.9mm) diameter, all body sizes.

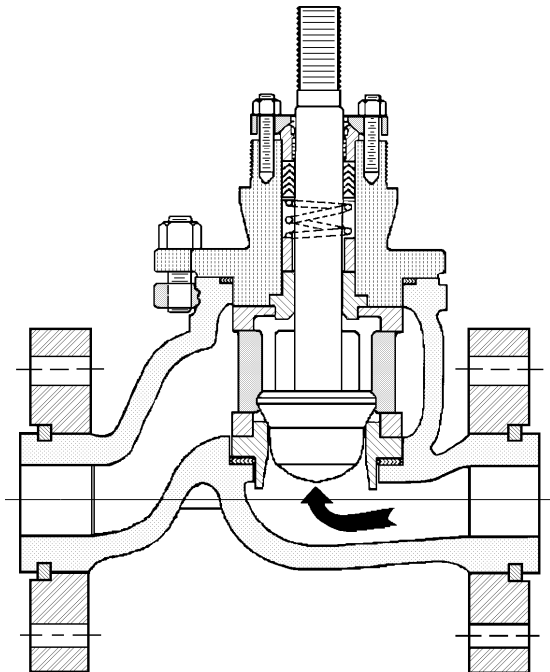

FIGURE 1

Body Sub-Assembly Internal Design – Metal Seated with Internal Live-Loading

Plug Travel:

Body Size inch (mm)	Travel/Stroke inch (mm)
1", & 1-1/2" (DN25, 40)	.750" (19.0)
2" (DN50)	1.125" (28.6)

Bonnet Bolting:

Zinc plated alloy steel.
CS Body/Bonnet: All standard and optional constructions.
Studs: ASTM A193, Gr. B7;
Nuts: ASTM A194, Gr. 2H.
SST Body/Bonnet: Std. construction and Opt-40 (NACE) Construction.
Studs: ASTM A193, Gr. B7;
Nuts: ASTM A194, Gr. 2H.
SST Body/Bonnet: Opt-35 High Temperature Construction (no plating).
Studs: ASTM A193, Gr. B8M, Cl. 2;
Nuts: ASTM A194, Gr. 8M-S1.

Packing Apparatus:

Std – Internal Live-Loaded & Jammed:
Flange – 316 SST;
Follower & Upper Guide – per Trim Designation Number.
Optional – External Live-Loaded:
Retainers – 316 SST;
Spacer – 316 SST;
Follower & Upper Guide – per Trim Designation Number;
Belleville Washers – 17-7PH SST.
All Designs – Bolting:
CS Body – All constructions;
Studs – 18-8 SST,
Nuts – 18-8 SST.
SST Body – All constructions except Opt-35;
Studs – 18-8 SST,
Nuts – 18-8 SST.
SST Body – Opt-35 High Temperature Construction;
Studs – ASTM A193, Gr. B8M, Cl. 2;
Nuts – ASTM A194, Gr. 8M-S1.

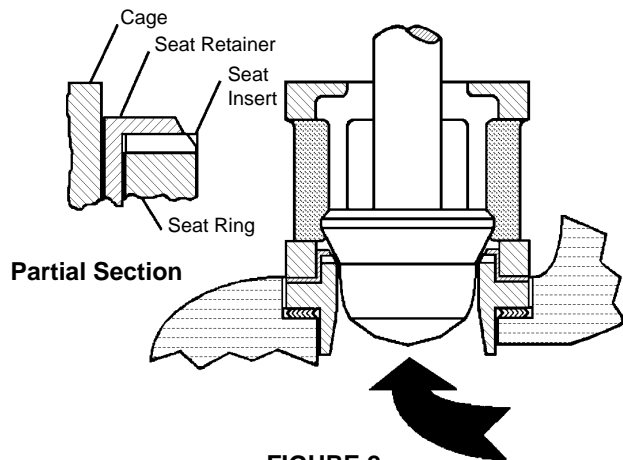

FIGURE 2

Composition Soft Seat Design

Packing:

All packing ring sets are complete with upper and lower non-extrusion adapters. **Live-Loaded (LL):** (See Figure 3.)

Standard: Internal LL, virgin TFE V-ring.

Opt-EXT: External LL, virgin TFE V-ring.

Opt-HTE: External LL, carbon graphite rings.

Opt-KRI: Internal LL, DuPont Kalrez/TFE rings with CRCC adapters.

Opt-KRE: Same as 'KRI', except external LL.

Jammed (Non-LL): (See "Option Specifications").

Opt-34: Dual packing, TFE V-ring, lantern ring spacer; 3 variations.

Opt-38J: Virgin TFE V-ring, dead-loaded.

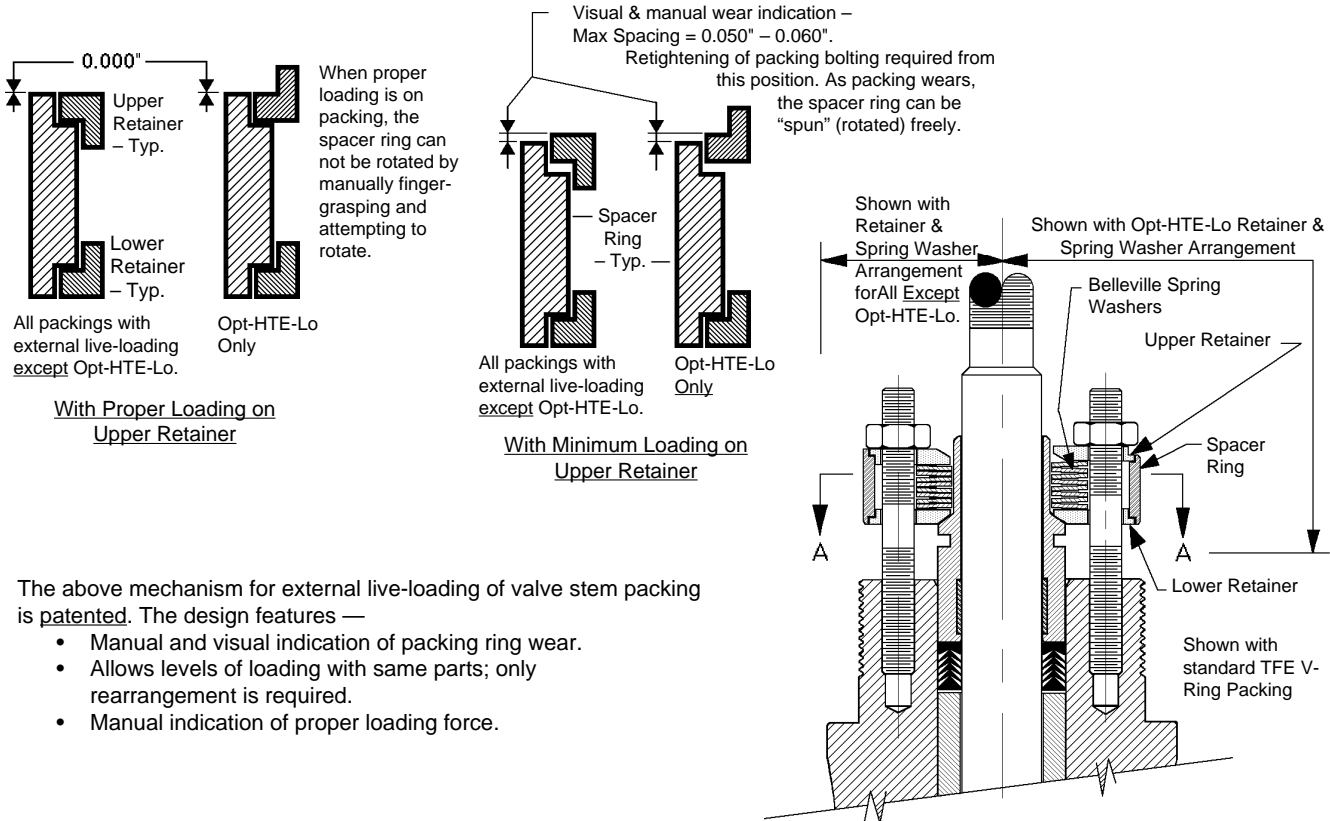

The above mechanism for external live-loading of valve stem packing is patented. The design features —

- Manual and visual indication of packing ring wear.
- Allows levels of loading with same parts; only rearrangement is required.
- Manual indication of proper loading force.

ACTUATOR SUB-ASSEMBLY SPECIFICATIONS

(Continued on page 5)

Size, Stroke & Volumes:

Basic Actuator Model	Diaphragm Area in ² (cm ²)	Nominal Stroke in (mm)	Volumes	
			Clearance in ³ (cm ³)	Displacement in ³ (cm ³)
55D	50 (325)	.750" (19.0)	26 (400)	37 (600)
55R			41 (700)	
75D or 75R	75 (475)	.750" (19.0)	75 (1200)	55 (900)
		1.125" (28.6)	75 (1200)	85 (1400)
115D	110 (700)	1.125" (28.6)	76 (1200)	131 (2100)
115R			84 (1400)	

Ambient Temperature: -20° to +180°F (-28° to +83°C).
-20° to +140°F (-29° to +60°C) with electrical accessories.

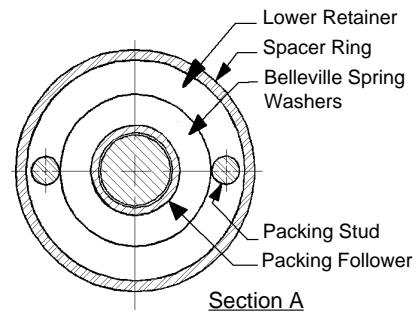

FIGURE 3
External Live-Loaded Packing Details

Bench Set & Max/Normal Pressures:

Bench Set psig (Barg)	Air Pressures	
	Normal Supply psig (Barg)	Design Max. psig (Barg)
5-15 (.34-1.03)	20	25
3-13 (.21-.90)	(1.4)	(1.7)
10-30 (.69-2.07)	35 (2.4)	40 (2.8)
6-26 (.41-1.79)		
7-30 (.48-2.07)		
6-29 (.41-2.00)		
8-30 (.55-2.07)		
6-28 (.41-1.93)		
9-30 (.62-2.07)		
6-27 (.41-1.86)		
6-30 (.41-2.07)		

NOTE: No range springs are available for split ranging. A positioner is required for split range input signal.

Materials:

Part	Material	
	Models 55/115	Model 75
Diaphragm	Neoprene with nylon mesh insert	Neoprene with dacron mesh insert
Casings - Upper and Lower	Pressed Carbon Steel	
Yoke	Cast Iron	
Stem	416 SST	
Diaphragm Plate	Cast Iron	
Spring Button	Cast Iron	
Spring Adjustor	18-8 SST	
Position Indicator	SST	
Bolting-Casings	Plated Steel	
Jam Nuts	18-8 SST	
Position Plate, Screws & Unit Nameplate	SST	
Bonnet/Yoke Nut	Plated Steel	

OPTION SPECIFICATIONS

Option -3:

MANUAL HANDWHEEL. Overrides the actuator spring force to allow manual stroking of the valve. Single acting design, top-mounted, enclosed handwheel. For ATO-FC action, handwheel operator “opens” the valve against spring force; may be utilized as a travel stop to prevent full closure. For ATC-FO action, handwheel operator “closes” the valve against spring force; may be utilized as a travel stop to prevent full opening.

Option -15:

STELLITED TRIM. For metal seated 316 SST designs only; limited to use with S1S, S1R, S1SE, S1RE or S1HT trim designation numbers only. Seat ring and plug seating surfaces are covered with Stellite #6 material. Recommended for flashing or partially cavitating liquid service, or where extended time periods of ON-OFF or low flow (less than 10% open) operation occur and good shutoff is required.

Option -26:

LEAK-OFF CONNECTION. 1/4" NPT tapped opening on bonnet. Complete with removeable steel plug for all body materials. Located between primary and secondary packing sets when supplied with Option -34, Dual Packing. See Figure 4.

Option -34:

DUAL PACKING. Two sets of standard TFE V-ring packing separated by a lantern ring of same material as trim material. Use for lethal, toxic, explosive, etc., type fluids, where extra packing sealing protection is desired; also used for vacuum service. *USE TABLE 4 FOR MAX. ALLOWABLE PRESSURE DROP.*

Arrangement A – Pressure inside valve is always greater than ambient pressure; see Figure 5.

Arrangement B – Pressure inside valve is always less than (i.e. vacuum) ambient pressure; see Figure 6.

Arrangement C – Pressure inside valve is alternately greater than or less than (i.e. vacuum) ambient pressure; see Figure 7.

Option -35:

HIGH TEMPERATURE CONSTRUCTION. Apply where temperatures from 450° to 750°F (232° to 400°C) are expected. Includes high strength, high temperature alloy bolting for the bonnet and packing retainer when applied with a SST body. Must select Opt -HTE stem packing design. Limited to use with trim designation S1HT ONLY.

Option -EXT:

TFE V-RING PACKING (External) Standard internal live-loaded (LL) design is replaced by patented external LL design. Includes SST Belleville spring washers enclosed within a SST spacer with SST upper and lower retainers (see Figure 3), and a variation of the standard packing follower. Temperature range: -20 to +450°F (-29 to +232°C).

Option -HTE:

HIGH TEMPERATURE PACKING. Includes patented externally live-loaded design. Packing set includes braided carbon yarn, graphite embedded upper and lower rings; high density graphite formed rings acting as non-extrusion adapters; and compressed carbon graphite ribbon

Option - HTE (Cont): formed into one-piece rings. Special packing follower includes carbon bushing. Temperature range: -20° to +750°F (-29° to +400°C). Opt-HTE is further classified as to max. inlet pressure— Opt-HTE-Lo is for inlet pressures up to 250 psig (17.2 Barg); Opt-HTE-Hi is for inlet pressures greater than 250 psig (17.2 Barg). **NOTE:** If application is for temperatures greater than 450 °F (232 °C), Opt-35 is also required.

Option -KRI: **KALREZ PACKING (Internal)** Standard packing is replaced with DuPont “Kalrez” fluoroelastomer, Series 500 KVSP packing set, consisting of one carbon filled TFE V-ring, two Kalrez V-rings, and upper and lower CRCC non-extrusion adapter rings. Uses standard internal live-loading. Temperature range: -20° to +450°F (-29° to +232°C).

Option -KRE: **KALREZ PACKING (External).** Incorporates external live-loaded features of packing Opt-EXT, and packing rings of packing KRI. Temperature range: -20° to +450°F (-29° to +232°C).

Option -38J: **JAMMED PACKING.** Live loading packing spring is replaced by a fixed spacer of same material as trim material; see Figure 8. **USE TABLES 2 AND 3 FOR MAX ALLOWABLE PRESSURE DROP.**

Option -40: **NACE SERVICE.** Internal wetted portions meet NACE standard MR0175-90 revision, when the exterior of the valve is not directly exposed to a sour gas environment, buried, insulated or otherwise denied direct atmospheric exposure. Apply in sour gas, sour crude, or service with hydrogen sulfide (H₂S) in the flow mixture. Limits effects of sulfide stress corrosion cracking. Use with CS or SST body/bonnet materials, and only with trim designations S40, S40E, S40T, or S40TE. Certificate of compliance supplied on request.

Option -55: **SPECIAL CLEANING.** Cleaned and packaged per Cashco Specification #S-1134. Suitable for oxygen service and other fluids. SST BODIES ONLY.

Option -56: **SPECIAL CLEANING.** Special cleaning procedure per Cashco Specification #S-1542. Suitable for fluids other than oxygen. For all body materials.

Option -95: **EPOXY PAINT.** Special epoxy painting for exterior surfaces. Utilized in harsh atmospheric conditions. Procedures and specs per Cashco Specification #S-1547.

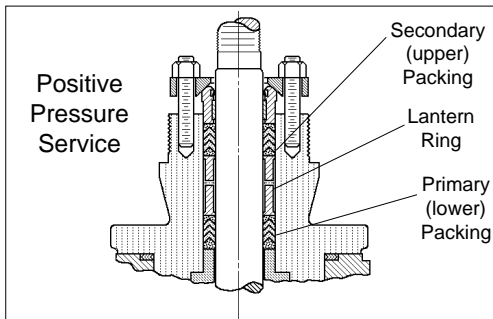

FIGURE 5
Dual Packing – Arr. “A”
Option-34A

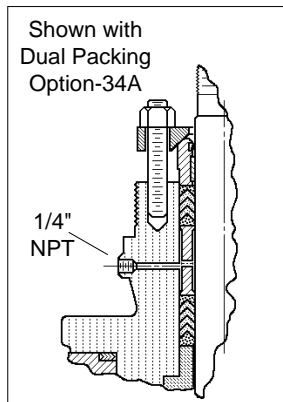

FIGURE 4
Leak-Off Conn.
Option-26

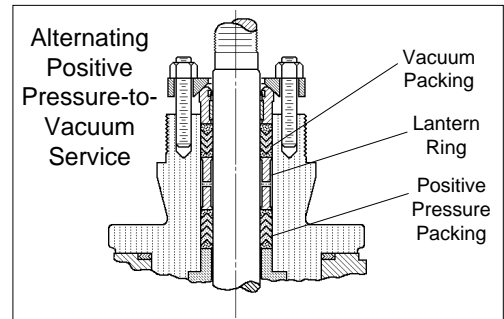

FIGURE 7
Dual Packing – Arr. “C”
Option-34C

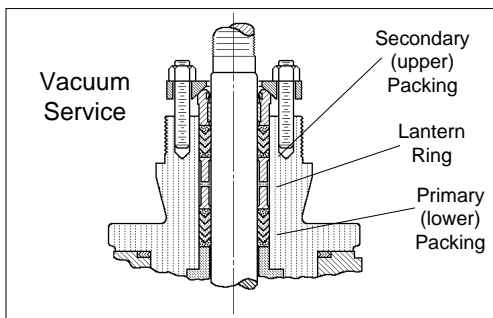

FIGURE 6
Dual Packing – Arr. “B”
Option-34B

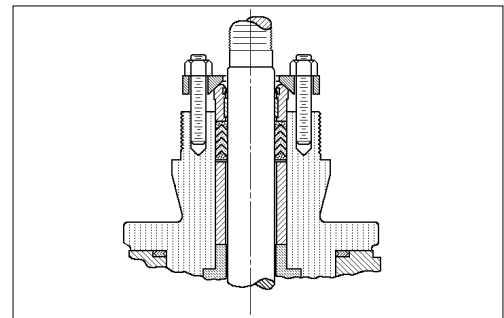

FIGURE 8
Jammed Packing
Option-38

MOUNTED ACCESSORY SPECIFICATIONS

Positioners:	<p><u>General.</u> Yoke mounted to unit. All feedback linkage exposed to elements of SST materials. Aluminum housing with corrosion resistant polyurethane paint. Standard with 2-gauge cluster. Pneumatic output load as required by actuator bench range. Adjustable zero, stroke, gain and damping settings. Field reversible action. Dedicated airset recommended.</p> <p><u>P/P Pneumatic.</u> Model 9540L. Accepts 3-15 psig (0.2-1.0 Barg); 2-way split ranges 3-9 or 9-15 psig (0.2-0.6 or 0.6-1.0 Barg) input signals. Plastic cover with see-thru panel to view internal gauges.</p> <p><u>I/P Electro-Pneumatic.</u> Model 9520L. Accepts 4-20 mA; 2-way split ranges 4-12 or 12-20 mA input signals. NEMA 3 enclosure, intrinsically safe. FM approved. Gauges mounted on external gauge block.</p> <p><u>Mounting Bracket.</u> P/P – Pneumatic uses a SST bracket. I/P – Electro Pneumatic uses a die cast aluminum bracket.</p>	<p>casing. 120 VAC, 60 Hz power supply. Class F coil, continuous duty. 0.125" (3 mm) orifice, 50 psid (3.4 Bard) maximum pressure drop.</p> <p><u>Gen. Purpose:</u> ASCO #8320G176. <u>X-Proof:</u> ASCO #EF8320G176. <u>Alternate SST:</u> Similar to standard unit, <u>except</u> with .094" (2.38 mm) orifice, 40 psid (2.75 Bard) maximum differential pressure, and 303 SST body. <u>Gen. Purpose:</u> ASCO #8320G201. <u>X-Proof:</u> ASCO #EF8320G201.</p> <p>Standard installation vents actuator and drives valve to failsafe position upon loss of electrical power.</p> <p><u>Standard:</u> Yoke mounted, rotary trip switch; contains 1-SPDT switch. Switch rating is 15A @ 125 or 250 VAC. UL/CSA rating L96. Up to two switch units may be mounted per valve. <u>Gen. Purpose:</u> Microswitch #OP-AR. NEMA 4 enclosure. <u>X-Proof:</u> Microswitch #EX-AR. For "hazardous locations" NEMA 7, Class 1, Groups C & D; NEMA 9, Class II, Groups E, F & G. <u>Alternate:</u> Proximity Controls Model #12ALO, 2-SPDT switches. Switch rating is 15A @ 125 or 250 VAC; proximity-type. UL listed for Class I, Groups A, B, C, D; Class II, Groups E, F, G; Div. 1 and 2. CSA, BASEEFA and CENELEC listed. Enclosure per NEMA 1, 2, 3, 3R, 3S, 4, 4X, 6, 7, 9, 12 and 13. <u>Alternate:</u> Proximity Controls Model #12GLOB, 2-SPDT Switches. Switch rating is 1A @ 125 VAC. BASEFA certified EX dIIC T6 per BS4683 Part 2, IP68. CENELEC certified EEX dIIC T6 per BS550: Parts 1 & 5.</p>
Air Tubing:	<p>Standard instrument air tubing is Imperial-Eastman "Impolene" thermo-plastic tubing with brass fittings.</p> <p>Optional copper tubing with brass fittings, or SST tube and fittings.</p>	Position Indicating Switches:
Airset:	<p>Model 5100P instrument air supply regulator. Use with positioners. Bracket mounted to actuator casing.</p>	
Solenoid Valve:	<p><u>Standard Brass:</u> Available in standard NEMA 3, 4 and 6 weatherproof model, or NEMA 4 & 7 explosion-proof model. Brass body, 1/4" female NPT connections. Nipple mounted or bracket mounted to actuator</p>	

APPLICATION AND SELECTION

The following procedure will help determine a suitable selection for an application. Consult Cashco area Representative for assistance in sizing.

- | | |
|---|---|
| <p>STEP 1. FIVE KNOWNNS. The following minimal parameters/information must be available before a selection procedure can begin:</p> <ol style="list-style-type: none"> a. Service Fluid – What is it? Liquid or gas? SG (std. cond.). b. Inlet Pressure – P₁ (upstream pressure). c. Outlet Pressure - P₂ (downstream pressure). d. Desired capacity – Cv, GPM, SCFH; minimum, maximum and normal. e. Fluid temperature – T₁, SG (actual). | <p>STEP 2. CHARACTER and RESERVE. Decide whether the inherent characteristic of the valve should be <u>equal percent</u> or <u>linear</u>. Also, decide the amount of <u>over-capacity</u> in the selection; i.e. =% character with 20% reserve capacity. (NOTE: A linear character gives "constant gain" throughout the full stroke. An equal percent character gives a "low gain" up to near 50% of full signal, a "medium gain" up to about 75% of full signal, and a "high gain" the last 25% of full signal.)</p> |
|---|---|

STEP 3. **CAPACITY.** Using the knowns from Step 1, calculate the maximum and minimum Cv required.

Example: Max Cv Req'd = 7.5 Cv
Min Cv Req'd = 0.8 Cv
=% Character
20% reserve capacity

Max Cv Available
 $7.5 \div 0.80 = 9.4 \text{ Cv}$

Select the body/orifice sizes that are near the 9.4 Cv Available level. Table 7 should be used as the character is =%.

Example: Preliminary selections –

- a. 1" @ 11.8 Cv Max, full port.
- b. 1-1/2" @ 10.4 Cv Max, reduced port.

STEP 4. **RANGEABILITY.** Check the Min Cv Available from Table 7 for the selection of Step 3.

- a. 0.24 Cv @ Min. Cv.
- b. 0.21 Cv @ Min Cv

As the Min Cv Req'd is greater than any of the previous Min Cv Available, all of the selections are acceptable at minimum flow level.

STEP 5. **FAILURE ACTION.** Consider the process related safety conditions to determine if the valve should "fail open" or "fail close" upon:

- a. loss of air supply pressure.
 - b. loss of electric power. *
 - c. loss of both supply air and electric power. *
- * Requires 3-way solenoid valve.

STEP 6. **P vs. T BODY RATINGS.** For the desired body material ensure that the actual design inlet temperature/pressure limits established in Table 1 are not exceeded.

STEP 7. **PRESSURE DROP & ACTUATOR SIZE.** Maximum pressure drop (ΔP) is normally experienced at shutoff flow. Knowing the maximum ΔP required, the desired action/failsafe position (ATO-FC or ATC-FO), the seat design (metal or composition soft), and the packing type, go to the correct table of Tables 2 through 5 to ensure the valve's capability.

Example: ΔP shutoff = 320 psid (22.1 Bard). Valve selected – 1-1/2" (DN40) @ 10.4 Cv Max, reduced port, TFE seat, TFE packing, ATO-FC action.

Selection: Use Table 3. Only acceptable actuator is Model 55R-10 with a 5-15 psig (.34-1.03 Barg) bench set range spring.

Note: *If a bench set had been selected such as a 10-30 psig (.69-2.07 Barg), i.e. other than a nominal 3-15 psig (.21-1.03 Barg); a positioner would have been required.)*

STEP 8. **MATERIALS.** Review Table 9. Select the desired trim from Table 6. Consider the use of Option -15, stellite seating surfaces. Consider leakage rate.

Reference materials vs. fluid corrosion tables for suitability of body and trim materials.

STEP 9. **ACCESSORIES.** Consider use of various valve installed accessories:

- a. P/P positioner
- b. I/P positioner
- c. Position limit switches
- d. Manual handwheel
- e. Solenoid valve
- f. Airset

TECHNICAL SPECIFICATIONS

**TABLE 1
MATERIAL PRESSURE / TEMPERATURE RATINGS**

Body/Bonnet Materials		Option Nos.	End Connection	English Units		Metric Units	
General	ASTM Spec.			Pressure (psig)	Temperature (°F)	Pressure (Barg)	Temperature (°C)
Cast Carbon Steel (CS)	A216, Grade WCB	None	150# Flanged	285	-20 to +100	19.6	-29 to +38
				260	200	17.9	94
				230	300	15.9	149
				200	400	13.8	205
				185	450	12.7	232
				155	550	10.7	288
				125	650	8.6	344
		95	750	6.5	400		
		-35 (T>450°F)	300# Flanged (Note 1)	740	-20 to +100	51.0	-29 to +38
				675	200	46.5	94
				655	300	45.2	149
				635	400	43.8	205
				615	450	42.4	232
				575	550	39.6	288
535	650			36.9	344		
505	750	34.8	400				
Cast Stainless Steel (SST)	A351 Grade CF3M	None	150# Flanged	275	-20 to +100	18.9	-29 to +38
				240	200	16.5	94
				215	300	14.8	149
				195	400	13.4	205
				180	450	12.4	232
				155	550	10.7	288
				125	650	8.6	344
		95	750	6.5	400		
		-35 (T>450°F)	300# Flanged (Note 2)	720	-20 to +100	49.6	-29 to +38
				620	200	42.7	94
				560	300	38.6	149
				515	400	35.5	205
				495	450	34.1	232
				465	550	32.1	288
445	650			30.7	344		
425	750	29.3	400				

NOTE 1: CS separable flanges with CS bodies.

NOTE 2: CS or SST separable flanges with SST bodies.

TABLE 2
MAXIMUM PRESSURE DROP – psid (Bard)
METAL SEATED
PACKING DESIGNS – STD, EXT, KRI, KRE, 38J

Actuator Action	Body Size Inch (mm)	Port-Orifice		Maximum Operating Pressure Drop psid (Bard)	Actuator		Air Supply Pressure psig (Barg)
		Description	Size inch (mm)		Bench Settings psig (Barg)	Model No.	
ATO-FC (Reverse)	1" (DN25)	Full	.750" (19.0)	320 (22)	5-15 (.34-1.03)	55R-10	20 (1.4)
		1-Step Reduced	.562" (14.3)	600 (41)			
		2-Step Reduced					
		3-Step Reduced	.332" (8.4)	740 (51)			
		4-Step Reduced	.205" (5.2)				
		5-Step Reduced	.155" (3.9)				
	6-Step Reduced						
	1-1/2" (DN40)	Full	.750" (19.0)	600 (41)	10-30 (.69-2.07)	55R-11	35 (2.4)
		Full	1.250" (31.8)	65 (4.5)	5-15 (.34-1.03)	55R-10	20 (1.4)
		Reduced	.750" (19.0)	320 (22)			
		Full	1.250" (31.8)	255 (17)	10-30 (.69-2.07)	55R-11	35 (2.4)
		Reduced	.750" (19.0)	600 (41)			
		Full	1.250" (31.8)	175 (12)	5-15 (.34-1.03)	75R-10	20 (1.4)
	2" (DN50)	Full	1.688" (42.9)	75 (5.2)	10-30 (.69-2.07)	75R-11	35 (2.4)
		Reduced	1.000" (25.4)	315 (21)	5-15 (.34-1.03)	75R-12	20 (1.4)
		Full	1.688" (42.9)	240 (16)	10-30 (.69-2.07)	75R-13	35 (2.4)
		Reduced	1.000" (25.4)	400 (27)			
		Full	1.688" (42.9)	150 (10)	5-15 (.34-1.03)	115R-10	20 (1.4)
Reduced		1.000" (25.4)	400 (27)				
	Full	1.688" (42.9)	400 (27)	10-30 (.69-2.07)	115R-11	35 (2.4)	
ATC-FO (Direct)	1" (DN25)	Full	.750" (19.0)	530 (36)	3-13 (.21-.90)	55D-10	20 (1.4)
		1-Step Reduced	.562" (14.3)	600 (41)			
		2-Step Reduced					
		3-Step Reduced	.332" (8.4)	740 (51)			
		4-Step Reduced	.205" (5.2)				
		5-Step Reduced	.155" (3.9)				
	6-Step Reduced						
	1-1/2" (DN40)	Full	.750" (19.0)	600 (41)	6-26 (.41-1.79)	55D-11	35 (2.4)
		Full	1.250" (31.8)	140 (9.6)	3-13 (.21-.90)	55D-10	20 (1.4)
		Reduced	.750" (19.0)	530 (36)			
		Full	1.250" (31.8)	215 (15)	6-26 (.41-1.79)	55D-11	35 (2.4)
		Reduced	.750" (19.0)	600 (41)			
		Full	1.250" (31.8)	300 (20)	3-13 (.21-.90)	75D-10	20 (1.4)
	2" (DN50)	Full	1.688" (42.9)	140 (9.6)	6-26 (.41-1.79)	75D-11	35 (2.4)
		Reduced	1.000" (25.4)	400 (27)	3-13 (.21-.90)	75D-12	20 (1.4)
		Full	1.688" (42.9)	210 (14)	6-26 (.41-1.79)	75D-13	35 (2.4)
		Reduced	1.000" (25.4)	400 (27)			
		Full	1.688" (42.9)	250 (17)	3-13 (.21-.90)	115D-10	20 (1.4)
Reduced		1.000" (25.4)	400 (27)				
	Full	1.688" (42.9)	400 (27)	6-26 (.41-1.79)	115D-11	35 (2.4)	

NOTE: All above pressure drop values are based on Flow-to-Open (FTO) direction. Consult factory before applying in FTC direction.

TABLE 3
MAXIMUM PRESSURE DROP – psid (Bard)
COMPOSITION SOFT SEAT
PACKING DESIGNS – STD, EXT, KRI, KRE, 38J

Actuator Action	Body Size Inch (mm)	Port-Orifice		Maximum Operating Pressure Drop psid (Bard)	Actuator		Air Supply Pressure psig (Barg)		
		Description	Size inch (mm)		Bench Settings psig (Barg)	Model No.			
ATO-FC (Reverse)	1" (DN25)	Full	.750" (19.0)	400 (27)	5-15 (.34-1.03)	55R-10	20 (1.4)		
		1-Step Reduced	.562" (14.3)						
		2-Step Reduced							
		3-Step Reduced	.332" (8.4)						
	1-1/2" (DN40)	Full	1.250" (31.8)	110 (7.6)	5-15 (.34-1.03)	55R-10	20 (1.4)		
		Reduced	.750" (19.0)	400 (27)					
		Full	1.250" (31.8)	300 (20)	10-30 (.69-2.07)	55R-11	35 (2.4)		
				225 (15)	5-15 (.34-1.03)	75R-10	20 (1.4)		
	2" (DN50)	Full	1.688" (42.9)	400 (27)	10-30 (.69-2.07)	75R-11	35 (2.4)		
				110 (7.6)	5-15 (.34-1.03)	75R-12	20 (1.4)		
		Reduced	1.000" (25.4)	375 (25)	10-30 (.69-2.07)	75R-13	35 (2.4)		
		Full	1.688" (42.9)	275 (19)					
Reduced		1.000" (25.4)	400 (27)						
Full		1.688" (42.9)	185 (12)	5-15 (.34-1.03)				115R-10	20 (1.4)
		400 (27)	10-30 (.69-2.07)	115R-11	35 (2.4)				
ATC-FO (Direct)	1" (DN25)	Full	.750" (19.0)	400 (27)	3-13 (.21-.90)	55D-10	20 (1.4)		
		1-Step Reduced	.562" (14.3)						
		2-Step Reduced							
		3-Step Reduced	.332" (8.4)						
	1-1/2" (DN40)	Full	1.250" (31.8)	190 (13)	3-13 (.21-.90)	55D-10	20 (1.4)		
		Reduced	.750" (19.0)	400 (27)					
		Full	1.250" (31.8)	265 (18)	6-26 (.41-1.79)	55D-11	35 (2.4)		
				350 (24)	3-13 (.21-.90)	75D-10	20 (1.4)		
	2" (DN50)	Full	1.688" (42.9)	400 (27)	6-26 (.41-1.79)	75D-11	35 (2.4)		
				175 (12)	3-13 (.21-.90)	75D-12	20 (1.4)		
		Reduced	1.000" (25.4)	400 (27)	3-13 (.21-.90)	75D-13	35 (2.4)		
		Full	1.688" (42.9)	240 (16)					
			285 (19)	6-26 (.41-1.79)				75D-10	20 (1.4)
			400 (27)	6-26 (.41-1.79)				115D-11	35 (2.4)

NOTE: All above pressure drop values are based on Flow-to-Open (FTO) direction. Consult factory before applying in FTC direction.

**TABLE 4
MAXIMUM PRESSURE DROP – psid (Bard)
METAL OR COMPOSITION SOFT SEATED with OPT-34A/B/C DUAL PACKING**

Actuator Action	Body Size Inch (mm)	Port-Orifice		Maximum Operating Pressure Drop psid (Bard)	Actuator		Air Supply Pressure psig (Barg)
		Description	Size inch (mm)		Bench Settings psig (Barg)	Model No.	
ATO-FC (Reverse)	1" (DN25)	Full	.750" (19.0)	530 * (36)	7-30 (.48-2.07)	55R-11	35 (2.4)
		1-Step Reduced	.562" (14.3)	600 * (41)			
		2-Step Reduced					
		3-Step Reduced	.332" (8.4)	740 * (51)			
		4-Step Reduced	.205" (5.2)				
		5-Step Reduced	.155" (3.9)	740 ** (51)			
	1-1/2" (DN40)	Full	1.250" (31.8)	100 (6.9)	7-30 (.48-2.07)	55R-11	
		Reduced	.750" (19.0)	400 (27)			
		Full	1.250" (31.8)	360 (25)	8-30 (.55-2.07)	75R-11	
	2" (DN50)	Full	1.688" (42.9)	175 (12)	8-30 (.55-2.07)	75R-13	
		Reduced	1.000" (25.4)	400 (27)			
		Full	1.688" (42.9)	350 (24)	9-30 (.62-2.07)	115R-11	
ATC-FO (Direct)	1" (DN25)	Full	.750" (19.0)	425 * (29)	6-29 (.41-2.00)	55D-11	35 (2.4)
		1-Step Reduced	.562" (14.3)	600 * (41)			
		2-Step Reduced					
		3-Step Reduced	.332" (8.4)	740 * (51)			
		4-Step Reduced	.205" (5.2)				
		5-Step Reduced	.155" (3.9)	740 ** (51)			
	1-1/2" (DN40)	Full	1.250" (31.8)	140 (9.6)	6-29 (.41-2.00)	55D-11	
		Reduced	.750" (19.0)	400 (27)			
		Full	1.250" (31.8)	300 (20)	6-28 (.41-1.93)	75D-11	
	2" (DN50)	Full	1.688" (42.9)	140 (9.6)	6-28 (.41-1.93)	75D-13	
		Reduced	1.000" (25.4)	400 (27)			
		Full	1.688" (42.9)	300 (20)	6-27 (.41-1.86)	115D-11	

NOTE: All above pressure drop values are based on Flow-to-Open (FTO) direction. Consult factory before applying in FTC direction.

* Maximum pressure drop with composition soft seat is 400 psid (27 Bard); value given is metal seat only.

** Metal seat only.

**TABLE 5
MAXIMUM PRESSURE DROP – psid (Bard)
METAL SEAT – HIGH TEMP. PACKING, OPT-HTE**

Actuator Action	Body Size Inch (mm)	Port-Orifice		Maximum Operating Pressure Drop psid (Bard)	Actuator		Air Supply Pressure psig (Barg)
		Description	Size inch (mm)		Bench Settings psig (Barg)	Model No.	
ATO-FC (Reverse)	1" (DN25)	Full	.750" (19.0)	425 (29)	6-30 (.41-2.07)	55R-11	35 (2.4)
		1-Step Reduced	.562" (14.3)	600 (41)			
		2-Step Reduced					
		3-Step Reduced	.332" (8.4)	740 (51)			
		4-Step Reduced	.205" (5.2)				
		5-Step Reduced	.155" (3.9)				
	1-1/2" (DN40)	Full	1.250" (31.8)	100 (6.9)	6-30 (.41-2.07)	55R-11	
		Reduced	.750" (19.0)	400 (27)			
	2" (DN50)	Full	1.250" (31.8)	300 (20)	7-30 (.48-2.07)	75R-11	
		Full	1.688" (42.9)	140 (9.6)	7-30 (.48-2.07)	75R-13	
		Reduced	1.000" (25.4)	400 (27)			
		Full	1.688" (42.9)	300 (20)	8-30 (.55-2.07)	115R-11	
ATC-FO (Direct)	1" (DN25)	Full	.750" (19.0)	320 (22)	6-30 (.41-2.07)	55D-11	35 (2.4)
		1-Step Reduced	.562" (14.3)	600 (41)			
		2-Step Reduced					
		3-Step Reduced	.332" (8.4)	740 (51)			
		4-Step Reduced	.205" (5.2)				
		5-Step Reduced	.155" (3.9)				
	1-1/2" (DN40)	Full	1.250" (31.8)	65 (4.5)	6-30 (.41-2.07)	55D-11	
		Reduced	.750" (19.0)	320 (22)			
		Full	1.250" (31.8)	240 (16)	6-29 (.41-2.00)	75D-11	
		Reduced	.750" (19.0)	400 (27)			
	2" (DN50)	Full	1.688" (42.9)	105 (7.2)	6-29 (.41-2.00)	75D-13	
		Reduced	1.00" (25.4)	400 (27)			
		Full	1.688" (42.9)	250 (17)	6-28 (.41-1.93)	115D-11	

NOTE: All above pressure drop values are based on Flow-to-Open (FTO) direction. Consult factory before applying in FTC direction.

**TABLE 6
TRIM MATERIALS VS. DESIGNATION NOS.**

Part Description	METAL SEAT – Trim Designation Nos.						
	S1S *	S1R *	S40 **	√ S1HT *	S1SE *	S1RE *	S40E **
Plug/Stem Assy.	316L SST	316L SST	316L SST	316L SST	316L SST	316L SST	316L SST
Seat Ring	316L SST	316L SST	316L SST	316L SST	316L SST	316L SST	316L SST
Cage	CF3M	CF3M	CF3M	CF3M	CF3M	CF3M	CF3M
Upper Stem Guide	Rulon Tape	Rulon Tape	Rulon Tape	Carbon	Rulon Tape	Rulon Tape	Rulon Tape
Lower Guide Bushing	Stellite #6	316L SST Rulon	316L SST Rulon	Stellite #6	Stellite #6	316L SST Rulon	316L SST Rulon
Packing Load Spring	Cold Worked 316 SST	Cold Worked 316 SST	Cold Worked Inconel X-750	None	None	None	None
Packing Follower	316L SST	316L SST	316L SST	316L SST	316L SST	316L SST	316L SST
Wiper Ring	***	***	***	None	None	None	None
Spacer	316L SST	316L SST	316L SST	316L SST	316L SST	316L SST	316L SST
Packing Design	Internal Live-Loaded			External Live-Loaded or Jammed			

Part Description	COMPOSITION / SOFT SEAT – Trim Designation Nos.					
	S3S	S3R	S40T **	S3SE	S3RE	S40TE **
Plug/Stem Assy.	316L SST	316L SST	316L SST	316L SST	316L SST	316L SST
Seat Ring	316L SST	316L SST	316L SST	316L SST	316L SST	316L SST
Cage	CF3M	CF3M	CF3M	CF3M	CF3M	CF3M
Upper Stem Guide	Rulon Tape	Rulon Tape	Rulon Tape	Rulon Tape	Rulon Tape	Rulon Tape
Lower Guide Bushing	Stellite #6	316L SST Rulon	316L SST Rulon	Stellite #6	316L SST Rulon	316L SST Rulon
Packing Load Spring	Cold Worked 316 SST	Cold Worked 316 SST	Cold Worked Inconel X-750	None	None	None
Packing Follower	316L SST	316L SST	316L SST	316L SST	316L SST	316L SST
Wiper Ring	***	***	***	None	None	None
Spacer	316L SST	316L SST	316L SST	316L SST	316L SST	316L SST
Seat Retainer	316L SST	316L SST	316L SST	316L SST	316L SST	316L SST
Seat Insert	TFE	TFE	TFE	TFE	TFE	TFE
Packing Design	Internal Live-Loaded			External Live-Loaded or Jammed		

√ Only trim recommended for temperatures greater than 450°F (232°C), and up to 750°F (400°C).

* Use these trim designation numbers for Option -15 Stellite Seating surfaces.

** Use these trims when application is required for NACE service.

*** Polyurethane / Molybdenum

Material	Material Specifications
316L SST	ASTM A479, S31603; Wrought Barstock, Annealed
CF3M	ASTM A351, Gr. CF3M; Cast 316L SST

TABLE 7
FLOW CAPACITY – Cv
EQUAL PERCENT (=%) CHARACTER
Cv @ 10% TRAVEL INCREMENTS
FL @ 10%; FL @ 100%
METAL or COMPOSITION SOFT SEAT

Body Size inch/(mm)	Port Size	FL @ 10% Travel	Minimum Flow	Percent of Travel - %										FL @ 100% Travel
				10	20	30	40	50	60	70	80	90	100	
1" (DN25)	Full	.90	.24	.4	.7	1.2	1.9	2.6	3.6	5.3	7.6	10.2	11.8	.90
	1-Step Reduced	.90	.14	.3	.6	.9	1.2	1.6	2.2	3.1	4.3	5.7	7.0	
	2-Step Reduced	.90	.12	.2	.4	.6	.8	1.0	1.3	1.7	2.3	3.0	4.1	
	3-Step Reduced	.90	.10	.14	.2	.3	.4	.5	.7	.9	1.3	1.8	2.5	
1-1/2" (DN40)	Full	.90	.52	1.2	2.3	3.4	4.5	6.3	8.8	13.7	18.5	22.8	26	.90
	Reduced	.90	.21	.6	.9	1.3	1.9	2.5	3.4	4.7	6.2	8.2	10.4	
2" (DN50)	Full	.90	.94	2.8	4.9	7.1	9.7	12.9	17.1	24	32	41	47	.90
	Reduced	.90	.36	1.0	1.8	2.6	3.4	4.8	6.3	8.2	10.8	14.4	18.2	

TABLE 8
FLOW CAPACITY – Cv
LINEAR (Lin) CHARACTER
Cv @ 10% TRAVEL INCREMENTS
FL @ 10%; FL @ 100%
METAL or COMPOSITION SOFT SEAT

Body Size inch/(mm)	Port Size	FL @ 10% Travel	Minimum Flow	Percent of Travel - %										FL @ 100% Travel
				10	20	30	40	50	60	70	80	90	100	
1" (DN25)	Full	.90	.25	1.2	2.5	3.9	5.2	6.5	7.8	9.2	10.5	11.7	12.7	.90
	1-Step Reduced	.90	.15	.8	1.5	2.2	3.1	3.8	4.6	5.4	6.2	6.9	7.5	
	2-Step Reduced	.90	.14	.4	.8	1.2	1.7	2.1	2.5	3.0	3.4	3.8	4.3	
	3-Step Reduced	.90	.08	.2	.5	.8	1.0	1.2	1.5	1.8	2.0	2.2	2.5	
	4-Step Reduced	.90	.03	.1	.2	.3	.4	.5	.6	.7	.8	.9	1.0 *	
	5-Step Reduced	.90	.02	.05	.10	.15	.20	.25	.3	.35	.40	.45	.50 *	
1-1/2" (DN40)	Full	.90	.54	2.6	5.0	7.4	10.0	12.6	15.2	18.2	21	24	27	.90
	Reduced	.90	.22	.9	1.8	2.7	3.7	4.6	5.7	6.8	8.0	9.4	10.8	
2" (DN50)	Full	.90	1.0	4.2	10.0	15.3	19.8	23	27	35	41	46	50	.90
	Reduced	.90	.39	1.9	4.0	6.1	8.0	10.0	12.0	13.9	15.8	17.9	19.4	

* Metal Seat ONLY

**TABLE 9
APPLICATION RECOMMENDATIONS**

	Fluid	Temperature Range			Options	Trim Designation Nos.
		T<250°F (T<121°C)	250°<T<450°F (121°<T<232°C)	450°<T≤750°F (232°<T≤400°C)		
GASES	Inert Industrial (N ₂ , He, Ar)	√	√	—	None, -EXT	S3S, S3R, S3SE, S3RE, S1S, S1R, S1SE, S1RE
		—	—	√	-35, -HTE	S1HT
	Oxygen	√	√	CF	-55, -EXT	S3S, S3R, S3SE, S3RE, S1S, S1R, S1SE, S1RE
		—	—	—	—	—
	Hydrocarbons - Clean	√	√	—	None, -EXT	All
		—	—	√	-15, -35, -HTE	S1HT
	Hydrocarbons - Dirty	√	√	—	-15, -34	S1S, S1R, S1SE, S1RE
		—	—	√	-15, -35, -HTE	S1HT
Corrosive - Clean	√	√	CF	-34, -EXT, -KRI, -KRE	S3R, S40T, S3RE, S40TE, S1R, S40, S1RE,	
Corrosive - Dirty	√	√	CF	-15, -34, -EXT -KRI, -KRE	S1S, S1R, S40, S1SE, S1RE, S40, S40E,	
Cryogenic	—	—	—	—	N/R	
LIQUIDS	Clean, Non-Cavitating, Non-Flashing	√	√	—	None, -EXT	S3S, S3R, S3SE, S3RE, S1S, S1R, S1SE, S1RE
		—	—	√	-15, -35, -HTE	S1HT
	Clean, Cavitating, Flashing	N/R	N/R	N/R	—	Recommend Applying Ranger QCT
	NACE (H ₂ S + HC's)	√	√	CF	-40, -KRI, -KRE, -EXT	S40, S40E, S40T, S40TE
	Corrosive	√	√	CF	-34, -EXT, -KRI, -KRE	S3R, S40T, S3RE, S40TE, S1R, S40, S1RE,
Abrasive	N/R	N/R	N/R	—	Recommend Applying Ranger QCT	
STEAM	P1 < 150 psig (10.3 Barg)	Saturated			None, -EXT	S1S, S1R, S1SE, S1RE, S3S, S3R, S3SE, S3RE
	150 psig < P1 < 400 psig (10.3 Barg < P1 < 27.6 Barg)	Saturated			-15	S1S, S1R, S1SE, S1RE
	Superheated	√	√	—	-15, -EXT	S1S, S1HT, S1SE
		—	—	√	-15, -35, -HTE	S1HT

CF = Consult Factory
N/R = Not Recommended

DIMENSIONS & WEIGHTS
FACE-TO-FACE DIMENSIONS PER ISA S75.03 ("Short")

ENGLISH UNITS – Inch & Lbs.

End Conn.	Dimensions	Body Size									
		1"		1-1/2"				2"			
		Basic Actuator Model No.									
		55D	55R	55D	55R	75D	75R	75D	75R	115D	115R
150# FLGD.	A *	7.25		8.75				10.00			
	B	3.19		3.75				4.38			
300# FLGD.	A *	7.75		9.25				10.50			
	B	3.44		4.00				4.62			
ALL	C	5.03		5.40				6.16			
	D	18.63	20.82	19.00	21.19	23.40	26.37	24.16	27.13	25.22	27.94
	E	25.76	30.13	26.13	30.50	31.34	35.59	32.10	36.75	32.40	35.12
	F	10.50		10.50		13.81		13.81		15.50	
	G	4.00		4.00		8.00		8.00			
SHIP WT. - LBS. **		52	58	64	70	84	94	103	113	132	166

METRIC UNITS – mm & kg

End Conn.	Dimensions	Body Size									
		DN25		DN40				DN50			
		Basic Actuator Model No.									
		55D	55R	55D	55R	75D	75R	75D	75R	115D	115R
150# FLGD.	A *	184		222				254			
	B	81		95				111			
300# FLGD.	A *	197		235				267			
	B	87		102				117			
ALL	C	128		137				156			
	D	473	529	482	538	594	670	613	689	640	709
	E	655	766	664	775	796	904	815	933	822	892
	F	267		267		351		351		394	
	G	102		102		203		203			
SHIP WT. - Kg **		24	26	29	32	38	43	47	51	60	75

* Face-to-Face per ISA S75.03 - 1984.

** Basic valve with actuator, no accessories or manual handwheel operator. Add for: positioner @ 4# (1.8 kg); limit switch @ 3# (1.4 kg); manual handwheel operator @ 8# (3.6 kg).

For NPT or SW End Connections, please specify Model 988.

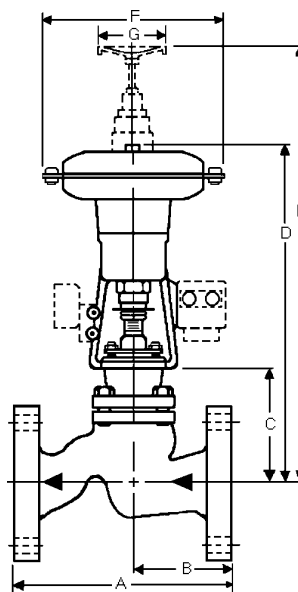

@DIM

NOTES

NOTES

