



MODEL SCV-30

SANITARY GLOBE-STYLE CONTROL VALVES

The Model SCV-30 * is a revolutionary, **throttling**, pneumatically actuated control valve. This unique design provides a geometrically characterized plug for superior **throttling** dynamics, plus the unit's ease of cleanability and maintenance meet the requirements of sanitary control valves.

The design incorporates a formed internal diaphragm that is bonded to a characterized metal plug. The diaphragm/body provides the smooth internal passages necessary for ease in cleaning and sanitizing. The plug head provides rigidity to the otherwise flexible diaphragm in the **throttling** zone where characterized control is desired.



MODEL SCV-30
Straight-Globe Pattern
with Model 30 Reverse Action Actuator

FEATURES

Design Concept:	A control valve for throttling applications.
Two Body Configurations:	Traditional straight-through globe pattern, or angle body pattern, both self-draining. Forged 316L SST body material.
Multiple Ports:	Both full and reduced port designs to optimize dynamic response.
Characteristic:	Linear.
Multiple Diaphragms:	Three to select from — EPDM, Fluorocarbon Elastomer, or Silicone.
Polished Interior:	Interior of wetted body mechanically polished and electro-polished to 10 micro-inch R_a finish.
Exterior Finish:	SST portions of body electro-polished. All other metallic exposed surfaces are of SST or painted with epoxy.
Readily Accessible:	Unit can be easily and quickly disassembled in-line for inspection or trim replacement. Quick disconnect stem.
Cleaning Capability:	Unit designed for clean-in-place (CIP) and steam-in-place (SIP) systems.
3A Construction:	 Selection of composition diaphragms bonded to metallic plug/stem meets 3A Sanitary Standards, Authorization No. 745.

APPLICATIONS

Used in pharmaceutical and biotechnical industries in production of shear sensitive microorganisms and many health care products for both human and animal consumption. Suitable for processed food and cosmetics production.

Would be found supporting fermenters, batching tanks, cookers, dryers and other similar sanitary equipment. Suitable in WFI (Water for Injection) systems.

Model SCV-30 is applicable in saturated steam up to 15 psig (1.03 Barg) in continuous service when R1 trim is utilized.

* Patented

STANDARD/GENERAL SPECIFICATIONS

Body Sizes: Full Port – 3/4", 1", 1-1/2".
Opt-12 Reduced Port – 1" and 1-1/2".

Body Form: Straight-Globe and Angle-Globe.

End Connections: Standard: Sanitary "Tri-Clamp®". Designed to seal against weld type clamp liners per ISO 2852.
Optional: Butt weld (Opt-24).

Inherent Characteristic: Linear.

Operating Pressure Range: Function of actuator bench set range:
Low: -7.5 psig to +35 psig (-0.5 Barg to +2.4 Barg)
High: -7.5 psig to +75 psig (-0.5 Barg to +5.1 Barg)

Operating Temperature Range: 0° to +300°F (-17° to +149°C)

Maximum Operating Pressure Drop: Function of actuator bench set range:
Low: 35 psid (2.4 Barg),
High: 75 psid (5.1 Barg).

Flow Capacity: Per ISA 75.11 standard. See Tables 3 & 4.

Maximum SIP Conditions: SIP – Steam-in-Place.
 Recommended: 20 psig @ SAT (1.4 Barg @ SAT).
 Maximum: 30 psig @ SAT (2.1 Barg @ SAT), but with reduced diaphragm life.

Body Size	Port Size	Straight		Angle	
		Cv	kv	Cv	kv
3/4"	Full	2.8	2.4	2.9	2.5
1"	Full	6.1	5.2	6.6	5.6
	Opt-12 Red.	3.4	2.9	3.6	3.1
1-1/2"	Full	10.4	8.9	11.7	10.0
	Opt-12 Red.	6.6	5.6	7.1	6.1

Rangeability: 30:1 (FTO only).

Flow Direction: FTO – Flow-to-Open. (Not recommended for FTC direction.)

Seat Leakage: Per ANSI/FCI 70-2 standard; Class VI, composition seated.

Actuator: Spring-diaphragm type. Non-field reversible action.
Direct: ATC-FO; Reverse: ATO-FC.

Direct: Increase in air "LOAD" extends actuator stem.
Reverse: Increase in air "LOAD" retracts actuator stem.
ATC-FO: Air-to-Close, Fail Open; Direct-acting.
ATO-FC: Air-to-Open, Fail Closed; Reverse-acting.

Exterior Finish: Body/Bonnet – Electro-polished.
 Actuator/Topworks – Epoxy paint per Cashco Spec. #S-1606, or SST.

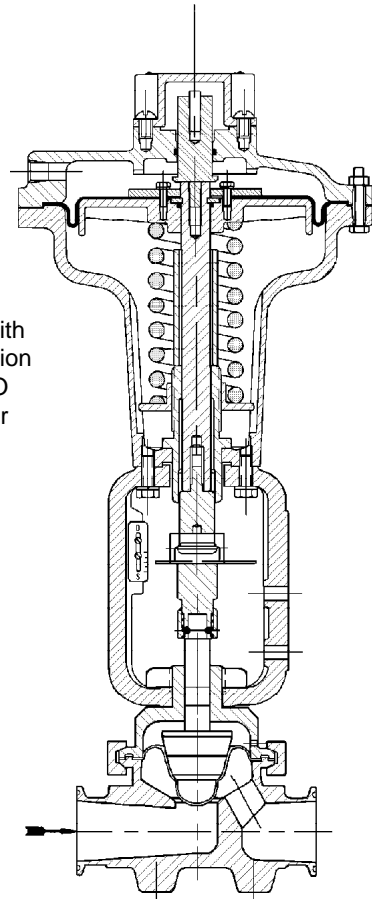

Shown with Direct Action ATC-FO Actuator

FIGURE 1 – STRAIGHT BODY

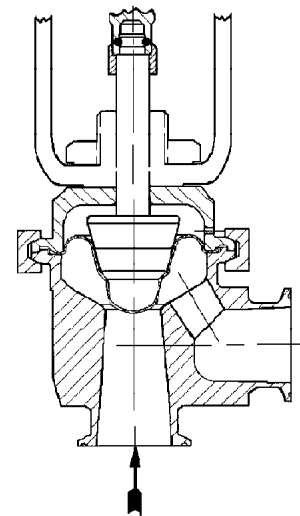

FIGURE 2 – ANGLE BODY

® Registered Tradename, Alfa-Laval Group, Tri-Clover Division.

BODY TECHNICAL SPECIFICATIONS

Port Size, Stroke:

Body Size	Port Size				Nominal Stroke	
	Full		Opt-12 Reduced			
	in.	mm	in.	mm	in.	mm
3/4"	.500	(12.7)	–	–	0.50	(12.7)
1"	.688	(17.5)	.500	(12.7)		
1-1/2"	1.000	(25.4)	.688	(17.5)		

NOTE: Trim is interchangeable based on port size as each has the same stroke, i.e. 1" - reduced port trim will directly transfer to a 3/4" - full port, either angle or straight pattern.

Installation Orientation: Internal surfaces sloped and oriented to give "self-draining" with valve plug "open" when installed per Figure 3.

Quick Disconnect: Design allows for quick change of complete body sub-assembly (with "Tri-Clamp®" end connections), or just internal trim replacement. Both levels of disassembly can be done within a few minutes, and neither requires recalibration of the positioner.

- clamped end connections,
- clamped bonnet,
- quick-disconnect stem coupler,

End Connection Details: Standard: For mating to piping with quick couple, mechanical joints; Alfa-Laval "Tri-Clamp®". See Figure 4.

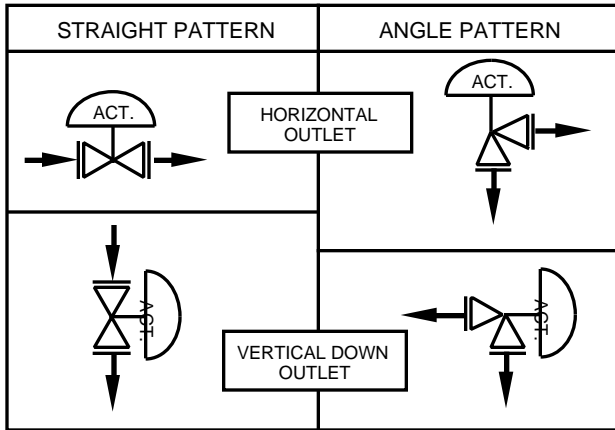

FIGURE 3: Installation Orientation

Nominal Body Size	Dimensions for Fig. 4					
	ID		OD		D1	
	in.	mm	in.	mm	in.	mm
3/4"	0.625	(15.9)	0.98	(24.9)	0.80	(20.3)
1"	0.856	(21.7)	1.984	(50.4)	1.738	(44.1)
1-1/2"	1.356	(34.4)	1.984	(50.4)	1.738	(44.1)

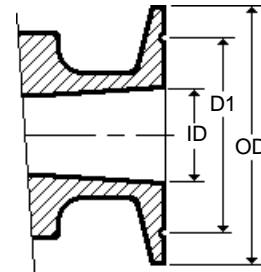

FIGURE 4 – Std. "Tri-Clamp®" End Connection

Nominal Body Size	Dimensions for Fig. 5				
	ID in. (mm)	OD in. (mm)	t in. (mm)	C1 in. (mm)	C2 in. (mm)
3/4"	0.620 (15.7)	0.750 (19.0)	.065 (1.65)	MIN. 0.69 (17.5)	0.09 (2.4)
1"	0.870 (22.1)	1.000 (25.4)			
1-1/2"	1.370 (34.8)	1.500 (38.1)			

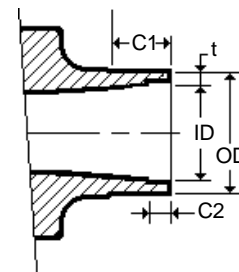

FIGURE 5 – Opt-24 Butt Weld End Connection

BODY SUB-ASSEMBLY MATERIAL SPECIFICATIONS

Body: Forged, ASTM F182, Gr. F316L (316L SST).

Body Wetted Surface Finish: Mechanically polished with 240 grit compound; manually polished where required. Electro-polished. Final surface is 10 micro-inch R_a . Final cleaning per Cashco Specification #S-1576.

Bonnet: Investment cast, ASTM A351, Gr. CF8M (316 SST), electro-polished after machining.

Plug/Stem Assembly: One-piece investment cast, ASTM A351, Gr. CF8M (316 SST). Electro-polished after machining.

Bonnet Clamp: Alfa-Laval Group, Tri-Clover Div., "Tri-Clamp®"; 304 SST electro-polished.

Diaphragm: (Elastomer + Mesh Insert.)

Trim Designation No.	Basic Material – Food Grade	FDA * Code of Federal (USA) Regulations No.
R1	EPDM + Dacron	21CFR177.2600
R2	FC Elast.** + Dacron	
R3	Silicone + Dacron	

* FDA - USA Food and Drug Administration

** Fluorocarbon Elastomer

Plug-to-Diaphragm Adhesive:

CSL Silicones, Inc., No. CSL 502, industrial silicone sealant/adhesive. Permitted under FDA Code of Regulations; No. 175.105; Color – Clear. Acceptable as “food grade” by U.S. Dept. of Agriculture and Agriculture Canada where incidental food contact may occur.

ACTUATOR TECHNICAL SPECIFICATIONS (Model 30)

Size, Stroke & Volume:

Basic Actuator Model No.	Diaphragm Area		Nominal Stroke		Volumes			
					Clearance		Displacement	
	in ²	cm ²	in	mm	in ³	cm ³	in ³	cm ³
30D or 30R	30	(200)	0.5	(12.7)	20	(330)	15	(250)

Bench Set Range:

Actuator Model No.	Unit Action	Bench Set Range			Supply Air Pressure	
		Desc.	psig	(Barg)	psig	(Barg)
30D-91	Direct: ATC-FO	Low	5–15	(.3–1.0)	20	(1.4)
30R-91	Reverse: ATO-FC					
30D-92	Direct: ATC-FO	High	9–27	(.6–1.9)	35	(2.4)
30R-92	Reverse: ATO-FC					

Ambient Temperature Range: 0° to +175°F (-17° to +80°C)

Field Reversibility: Actuator is NOT field reversible without change in actuator parts. Consult Factory for reversing.

ACTUATOR SUB-ASSEMBLY MATERIAL SPECIFICATIONS (Model 30)

Diaphragm Casings: Cast aluminum, including cap.

Spring Housing: Integral with diaphragm casing; cast aluminum.

Yoke: Cast aluminum.

Yoke Nut: SST.

Diaphragm: Reinforced Neoprene.

Diaphragm Plate: Cast aluminum.

Spring: Zinc plated steel.

Spring Button: Aluminum.

Bolting – Diaphragm Casing, Yoke-to-Diaphragm Casing: SST.

Travel Indicator, Indicator Plate, & Screws: SST.

Spring Adjustor & Jam Nuts: SST.

Stem: 316 SST.

OPTION SPECIFICATIONS

Option-3: MANUAL HANDWHEEL. Overrides the actuator spring force to allow manual stroking of the valve. Single acting design, top-mounted, enclosed handwheel. for ATO-FC action, handwheel operator “opens” the valve against spring force; may be utilized as a travel stop to prevent full closure. for ATC-FO action, handwheel operator “closes” the valve against spring force; may be utilized as a travel stop to prevent full opening.

Option-12: REDUCED PORT. Standard full port body is replaced with an alternate body with its integral reduced port. See Pg. 3, “Port

Size & Stroke” for actual port size. NOTE: To convert from one port size to the other port size for a given body size requires that the body be replaced as well as the plug/stem/diaphragm sub-assembly.

Option-24: BUTT WELD END CONNS – 16 Ga. Alternate to “Tri-Clamp®” mechanical quick connect end connections. For connecting to 16 Ga. OD tubing. For butt weld jointing using automatic orbital welding process. Dimensions for the standard Opt-24 butt weld are indicated in Figure 5 on page 3; for butt welds of different dimensions consult factory.

APPLICATION AND SELECTION

The following procedure will help determine a suitable selection for an application. Consult your Cashco area representative for assistance in sizing, selection, and noise prediction by computer.

- | | |
|--|--|
| <p>STEP 1. <u>FIVE KNOWNs</u>. The following minimal parameters/information must be available before a selection procedure can begin:</p> <ul style="list-style-type: none"> a. Service Fluid – What is it? Liquid or gas? SG (std. cond). b. Inlet Pressure - P_1 (upstream pressure). c. Outlet Pressure - P_2 (downstream pressure). d. Desired capacity - Cv, GPM, SCFH; minimum, maximum and normal. e. Fluid temperature - T_1, SG (actual). | <p><u>Example:</u> Max Cv Req'd = 8.3 Cv
 Min Cv Req'd = 1.1 Cv
 Reserve = 20%
 Max Cv Req'd = 1.20 x 8.3 Cv
 = 10.0 Cv.</p> <p>Select a body size and port nearest to 10.0 Cv using Table 3 for a straight-globe body, or Table 4 for an angle-globe body.</p> <p><u>Selection –</u>
 1-1/2" straight-globe body, Full Port:
 Cv = 8.3 @ 78% travel,
 Cv = 1.1 @ 13% travel,
 Max Cv Available = 10.4.</p> |
| <p>STEP 2. <u>P vs. T BODY RATINGS</u>. Ensure that the pressure/temperature limits established in Table 1 are not exceeded.</p> | |
| <p>STEP 3. <u>INLET PRESSURE</u>. Select the actuator bench set range as "low" or "high" based on the limits given in Table 2.</p> | <p>STEP 8. <u>RANGEABILITY</u>. Check the minimum Cv of the selection of Step 7. Always attempt to keep the selection above 10% travel at minimum Cv. Example of Step 7. is suitable.</p> |
| <p>STEP 4. <u>PRESSURE DROP</u>. Select the actuator bench set range as "low" or "high" based on the limits given in Table 2.</p> <p><i>NOTE: Maximum ΔP frequently occurs at shutoff condition.</i></p> | <p>STEP 9. <u>TRIM MATERIALS</u>. Select the desired diaphragm material and corresponding trim designation number.</p> |
| <p>STEP 5. <u>ACTUATOR MODEL</u>. Determine the full actuator model number by determining the failsafe action desired of the control valve together with the results of Steps 3. and 4. above.</p> | <p>STEP 10. <u>END CONNECTION</u>. Determine the desired end connection of the two choices available.</p> |
| <p>STEP 6. <u>BODY PATTERN</u>. Determine if a straight-inline body or angle body is desired.</p> | <p>STEP 11. <u>ACCESSORIES</u>. Consider use of various unit installed accessories:</p> <ul style="list-style-type: none"> a. P/P positioner, b. I/P positioner, c. Solenoid valve, d. Limit switch(es). |
| <p>STEP 7. <u>CAPACITY</u>. Determine the amount of reserve capacity desired. Calculate the maximum and minimum Cv Required.</p> | <p>STEP 12. <u>OPTIONAL CONSTRUCTION</u>. Go through the listing of available options and determine if some are desired not already selected.</p> |
| | <p>STEP 13. <u>PRODUCT CODE</u>. Go to the back of this bulletin and develop the required "product code".</p> |

MOUNTED ACCESSORY SPECIFICATIONS

- | | |
|----------------------------|---|
| <p>Positioners:</p> | <p><u>General</u>. Yoke mounted to unit. All feedback linkage exposed to elements of SST materials. Aluminum housing with corrosion resistant polyurethane paint. Standard with 2-gauge cluster. Pneumatic output load as required by actuator bench range. Adjustable zero, stroke, gain and damping settings. Field reversible action. Dedicated airset recommended.</p> <p><u>P/P Pneumatic</u>. Model 9540L. Accepts 3-15 psig (0.2-1.0 Barg); 2-way split ranges 3-9 or 9-15 psig (0.2-0.6 or 0.6-1.0 Barg) input signals. Plastic cover with see-through panel to view internal gauges.</p> <p><u>I/P Electro-Pneumatic</u>. Model 9520L. Accepts 4-20 mA; 2-way split ranges 4-12 or 12-20 mA input signals. NEMA 3 enclosure, intrinsically safe. FM approved. Gauges mounted on external gauge block.</p> <p><u>Mounting Bracket</u>. P/P Pneumatic uses a SST bracket.
 I/P Electro Pneumatic uses a die cast aluminum bracket.</p> |
|----------------------------|---|

Air Tubing: Standard instrument air tubing is Imperial-Eastman "Impolene" thermo-plastic tubing with brass fittings. Rated to 250 psig (17 Barg) and -20 to +200°F (-28.6 to +93.7°C).

Optional copper tubing with brass fittings, or SST tube and fittings.

Airset: Model 5100P instrument air supply regulator. Use with positioners. Bracket mounted to actuator casing.

Solenoid Valve: Standard Brass: Available in standard NEMA 3, 4 and 6 weatherproof model or NEMA 4 and 7 explosion-proof model. Brass body, 1/4" female NPT connections. Nipple mounted or bracket mounted to actuator casing. 120 VAC, 60 Hz power supply. Class F coil, continuous duty. 0.125" (3 mm) orifice, 50 psid (3.4 Bard) maximum pressure drop.

Gen. Purpose: ASCO #8320G176.

X-Proof: ASCO #EF8320G176.

Alternate SST: Similar to standard unit, except with 303 SST body.

Gen. Purpose: ASCO #8320G201.

X-Proof: ASCO #EF8320G201.

Standard installation vents actuator and drives valve to failsafe position upon loss of electrical power.

Position Indicating Switch:

Proximity Controls Model #12ALO, 2-SPDT switches. Switch rating is 15A @ 125 or 250 VAC; Proximity type. UL listed for Class I, Groups A, B, C, D; Class II, Groups E, F, G; Div. 1 and 2. CSA, BASEEFA and CENELEC listed. Enclosure per NEMA 1, 2, 3, 3R, 3S, 4, 4X, 6, 7, 9, 12 and 13.

TECHNICAL SPECIFICATIONS

**TABLE 1
MAXIMUM PRESSURE vs. TEMPERATURE RATINGS**

Body Size	End Connection	Pressure		Temperature	
		psig	(Barg)	°F	(°C)
3/4"	Std. "Tri-Clamp®— or Opt-25 Butt Weld	75	(5.1)	300°	(149°)
1"					
1-1/2"					

**TABLE 2
MAXIMUM INLET PRESSURE & PRESSURE DROP**

Actuator		Maximum Valve Pressure				Supply Air Pressure	
Desc.	Model Number	Inlet		Drop		psig	(Barg)
		psig	(Barg)	psid	(Bard)		
Low	30D-91	35	(2.4)	35	(2.4)	20	(1.4)
	30R-91						
High	30D-92	75	(5.1)	75	(5.1)	35	(2.4)
	30R-92						

TABLE 3
Cv CAPACITY — STRAIGHT-GLOBE
 $F_L = 0.9$

Body Size	Port Description	Cv @ % Travel										
		Min.	10%	20%	30%	40%	50%	60%	70%	80%	90%	100%
3/4"	Full	0.1	0.2	0.5	0.8	1.0	1.3	1.6	1.9	2.4	2.6	2.8
1"	Full	0.2	0.9	1.5	2.1	2.7	3.2	4.0	4.6	5.3	5.8	6.1
	Opt-12 Reduced	0.1	0.2	0.5	0.8	1.0	1.3	1.6	1.9	2.4	3.0	3.4
1-1/2"	Full	0.3	1.0	1.6	2.4	3.4	4.5	5.5	6.9	8.7	9.6	10.4
	Opt-12 Reduced	0.2	0.9	1.5	2.1	2.7	3.2	4.0	4.7	5.4	6.0	6.6

TABLE 4
Cv CAPACITY — ANGLE-GLOBE
 $F_L = 0.9$

Body Size	Port Description	Cv @ % Travel										
		Min.	10%	20%	30%	40%	50%	60%	70%	80%	90%	100%
3/4"	Full	0.1	0.2	0.5	0.7	1.0	1.2	1.5	1.8	2.3	2.6	2.9
1"	Full	0.2	0.9	1.6	2.1	2.7	3.2	3.9	4.6	5.4	6.0	6.6
	Opt-12 Reduced	0.1	0.2	0.5	0.7	1.0	1.2	1.5	1.8	2.3	2.9	3.6
1-1/2"	Full	0.2	0.9	1.5	2.3	3.4	4.4	5.6	7.0	8.6	10.2	11.7
	Opt-12 Reduced	0.2	0.9	1.5	2.1	2.7	3.2	4.0	4.7	5.4	6.3	7.1

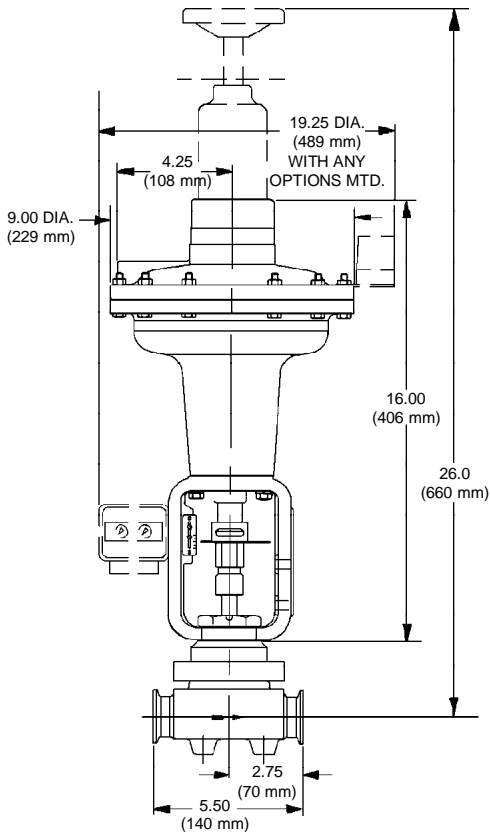

Model SCV-30 - Straight-Globe Body
Sizes 3/4", 1" and 1-1/2"

FIGURE 6

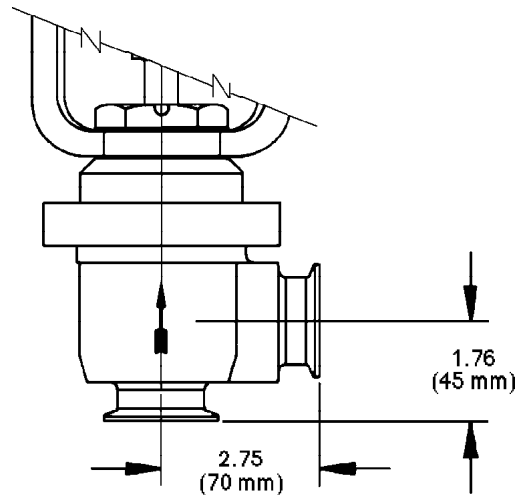

Model SCV-30 – Angle-Globe Body
Sizes 3/4", 1" and 1-1/2"

FIGURE 7

SHIP WEIGHT
 (Both Bodies) –
 29 lbs. (13 kg)

PRODUCT CODE 02/01/96

TABLE 2

BODY / BONNET MATERIAL	BODY PATTERN	
	STRAIGHT GLOBE	ANGLE GLOBE
	CODE	CODE
Forged 316L SST / Investment Cast 316 SST	A	G

TABLE 1

BODY SIZE	PORT SIZE	
	FULL PORT	OPT-12 REDUCED
	CODE	CODE
3/4"	5	—
1"	6	C
1-1/2"	8	D

TABLE 3

TRIM DESIGNATION NO.	CODE
EPDM – 316 SST	R1
Fluorocarbon Elastomer – 316 SST	R2
Silicone – 316 SST	R3

TABLE 4

END CONNECTION	CODE
Sanitary, Tri-Clamp	S
Opt-24, Butt Weld	B

TABLE 5

ACTUATOR				
DESC.	BENCH SET-psig	ACTION	MODEL	CODE NO.
LOW	5-15	Rev: ATO-FC	30R-91	1
		Dir: ATC-FO	30D-91	2
HIGH	9-27	Rev: ATO-FC	30R-92	3
		Dir: ATC-FO	30D-92	4

Size & Bench Set

Body Pattern and Material

Trim Material

End Connections

Actuator

Positioner

Airset

Accessories

Position Limit Switches

Tubing & Fittings

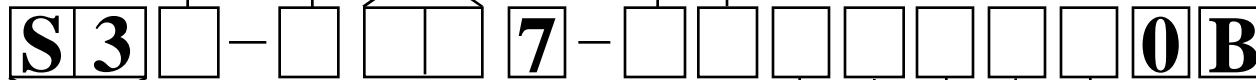

**MODEL "SCV-30"
SANITARY CONTROL VALVE**

TABLE 6

POSITIONER						CODE
Special Construction						X
No Positioner						0
I/P-Electro-Pneu. Model #9520L	CODE w/Airset	CODE wo/Airset	P/P-Pneumatic Model #9540L	CODE w/Airset	CODE wo/Airset	
Direct 4-20 ma	A	G	Direct 3-15 psig	1	R	
Reverse 20-4ma	B	H	Reverse 15-3 psig	2	S	
Direct Split Range 4-12ma	C	J	Direct Split Range 3-9 psig	5	V	
Direct Split Range 12-20 ma	D	K	Direct Split Range 9-15 psig	6	W	
Reverse Split Range 12-4ma	E	L	Reverse Split Range 15-9 psig	7	Y	
Reverse Split Range 20-12ma	F	M	Reverse Split Range 9-3 psig	8	Z	

When ordering a valve per one of Cashco's special drawings, the code "X" and the 5-digit number following override all other options. Otherwise, proceed with the following tables.

AIRSET RANGE	CODE
NONE- no Airset	0
5-15 psig Bench Setting (0-30 psig)	A
9-27 psig Bench Setting (0-60 psig)	B

TABLE 10

ACCESSORIES	CODE
NONE (other than indicated on this Coder Sheet)	0
Manual Handwheel	A
VALVE MTD ACCESSORIES Any of the following: 3-Way Solenoid Valve 764P Press Controller Extra Airset(s) I/P Transducer Lockup Valve	9

Note: Use of a "9" code requires that a "99 Coder" sheet be completed.

TABLE 7

TUBING & FITTINGS	CODE
NONE(NO Positioner, airset, solenoid, etc.)	0
STD-Impolene Plastic Tubing, Brass Fittings	1
Copper Tubing, Brass Fittings	2
SST Tubing and Fittings	3

TABLE 8

POSITION LIMIT SWITCHES				
MFGR/ MODEL	TYPE	NO.OF SWITCH UNITS *	TRIP POSITIONS	CODE
NONE				0
Proximity Controls #12ALO	Proximity Rotary Trip X-Proof	2	Plug Closed & Full Open	K

* Each "switch unit" contains 1-SPDT switch.

Cashco, Inc.
P.O. Box 6
Ellsworth, KS 67439-0006
PH (913) 472-4461
Fax # (913) 472-3539
Printed in USA SCV-30-TB

-gh

@PCM