



MODEL SCV-S

SANITARY PNEUMATIC CONTROL VALVE BODY

SECTION I

I. DESCRIPTION AND SCOPE

Model SCV-S is a pneumatically actuated, globe-style control valve for throttling sanitary or biotechnological applications. The globe body comes in two variations - straight-globe pattern and angle-globe pattern. The valve body is available with metal seated construction only. The wetted metallic body portion is of forged 316L SST mechanically and electro-polished to a 10 micro-inch R_a finish.

The unit is available with standard Tri-Clover® sanitary end connections. Butt-weld end connections are available as the Opt-24 optional construction.

The unit is available with the following accessory choices: P/P or I/P positioner, airset, travel limit switches, 3-way solenoid, and manual handwheel operator.

The unit is supplied only with a field-reversible, spring-diaphragm actuator, Model 30. The actuator connector-to-valve stem is a screwed joint design; an Opt.- 68 Quick Disconnect Stem is also available.

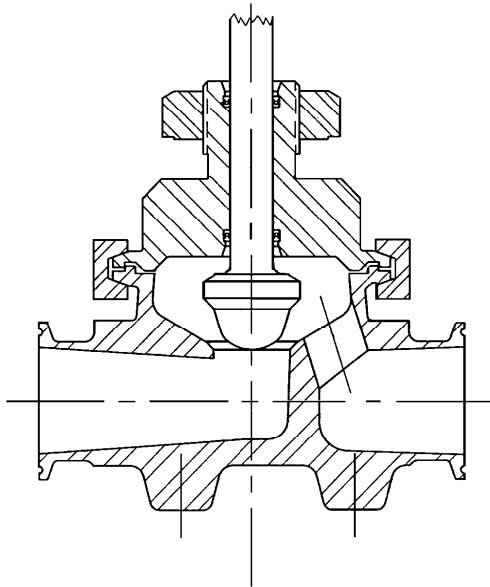

Figure 1: Model SCV-S, Straight-Globe Body

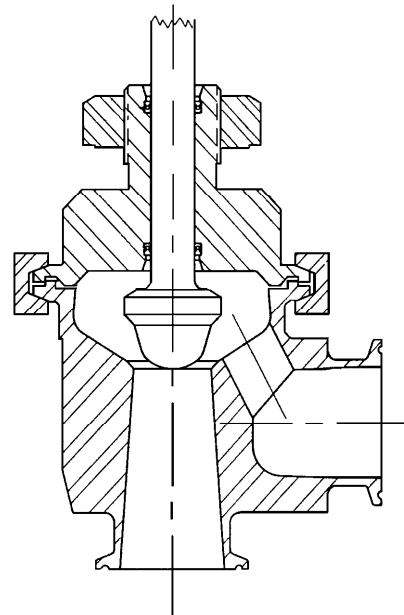

Figure 2: Model SCV-S, Angle-Globe Body

ATC-FO - Air to Close, Fail Open
ATO-FC - Air to Open, Fail to Close
CCW - Counter-Clockwise Rotation
CIP - Clean-in-Place
CW - Clockwise Rotation
DIR - Direct Acting
IAS - Instrument Air Supply

I/P - Electric Current Input/Pneumatic Output
P/P - Pneumatic Input/Pneumatic Output
REV - Reverse Acting
SIG - Controller Output Signal
SIP - Steam-in-Place
V - Vent
ZS - Position Switch

SECTION II

II. REFERENCES

Refer to Technical Bulletin SCV-S-TB for technical specifications of a Model SCV-S coupled with a Cashco Model-30 actuator.

Refer to the following Installation, Operation and Maintenance Manuals (IOM's) for devices mounted to a Model SCV-S or it's actuator:

<u>P/P Positioner</u>	<u>I/P Positioner</u>	<u>Actuator</u>
IOM-9540L	IOM-9520L	IOM-30

SECTION III

III. OPERATION CONSIDERATIONS

A. Clean-in-Place (CIP):

1. Control valve unit must be properly oriented per Section IV.A. to assure self-draining of valve's internal passages.
2. Control valve unit comes in the direct action, ATC-FO arrangement or the reverse action, ATO-FC arrangement. Valve should be in the full open position before initiation of the CIP procedure. Control system must accommodate this capability.
3. Cleaning fluid may flow in either direction.
4. Cleaning fluid pressure must not exceed 50 psig (3.5 Barg).
5. Cleaning fluid temperature must not exceed 366°F (186°C).
6. Cleaning fluid must be compatible with wetted materials.

B. Steam-in-Place (SIP):

1. Orientation to be same as CIP, Section III.A.1.
2. Steam may flow from either direction.
3. Recommended 30 psig @ SAT (2.1 Barg @ SAT). Valve must be in the full open during the SIP procedure.

C. Hose-Down Cleaning:

1. Standard Model SCV-S control valve units supplied with I/P positioners are NOT designed to allow hose-down washing of the unit's exterior.

D. Instrument Air Supply - IAS:

1. For Model SCV-S with a positioner recommend using cryogenically produced nitrogen gas, or oil-free compressed air desiccant dried to -40°F(-40°C) dew point, filtered to 10 microns or less as the IAS source.
2. All exhaust/vent air utilized by the Model SCV-S unit enters the ambient environment.

SECTION IV

IV. INSTALLATION

A. Orientation:

1. Standard orientation is with the yoke with position indicator plate and valve body outlet port in same plane. If an alternate arrangement is necessary, loosen yoke nut (8) securing yoke (1) to valve bonnet (2) approximately three revolutions. Rotate actuator assembly (AA) to desired position with respect to body assembly (BA). Re-tighten yoke nut (8). **NOTE:** This procedure can be done in-line.
2. Valve body must be installed in a horizontal or vertical plane where the outlet connection flow direction is downwards or horizontal (see Figure 3). Failure to comply will cause the

self-draining of the internal passages to be nullified, allowing CIP cleaning/flushing fluids to be ponded.

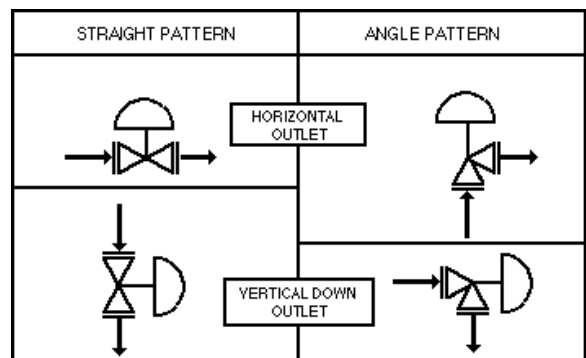

Figure 3: Installation Orientation

SECTION V

V. MAINTENANCE

A. General:



WARNING

SYSTEM UNDER PRESSURE. Prior to performing any body disassembly or removal for maintenance, inspection or cleaning, isolate the valve body from the system and relieve all pressure. Failure to do so could result in personal injury.

1. Maintenance procedures hereinafter are based upon removal of the control valve unit from the piping system where installed. Any disassembly is assumed to be in a suitably equipped work shop.
2. Owner should refer to owner's procedures for removal, handling and cleaning of non-reusable parts, i.e. gaskets, diaphragm, etc.
3. Valves supplied from the factory do not use any aid in gasket or diaphragm sealing such as oil, sealant, or pipe dope in the wetted portions of the valve body assembly. Such sealing aids should not be required and are not recommended.
4. Reference Figures 4 through 7 for identification of item numbers.
5. All item numbers that are with respect to the body assembly (BA) will be in parenthesis and not underscored; i.e. (1). All item numbers that are with respect to the actuator and positioner assemblies will be in parenthesis and underscored; i.e. (1).

B. Separation of Body/Actuator Assemblies:

1. Place body (1) into a vise with the actuator assembly (AA) in the upwards position.
2. Place matchmarks between the yoke (1), bonnet (2), Tri-Clamp® (4), and body (1).
3. Using an overhead hoist, rig the actuator assembly (AA) with sling or rope for overhead support. Remove slack from supports.
4. Using a blunt end tool, hammer rap the tool to loosen yoke nut (8), turning CCW (viewed from actuator end). Fully remove yoke nut (8). **NOTE:** For units with Opt-68 Quick Disconnect Stem proceed to Section V.D.
5. **For ATO-FC (reverse) Action Units - Model 30R Actuator**
 - a. Raise the actuator assembly (AA) approximately 1/2 inch (13 mm)

- b. Observe position/orientation of position indicator disc (20) and positioner accessory plate (AP) secured by stem jam nut (17).
- c. Place wrench on jam nut (17) and on adaptor (73) hex surfaces.
- d. Loosen stem jam nut (17) by rotating CCW (viewed from valve body end) approximately the 1/2 inch (13mm) the actuator assembly (AA) was raised. Keep count of the number of revolutions to disengage the plug/stem (3) in the following box for Step d. **NOTE:** If the rotation of the plug/stem (3) becomes "stiffer", STOP! The plug (3) head has contacted the integral body (1) seat. Do not rotate plug (3) against body (1) seat!

No. of revolutions to disengage plug/stem from actuator stem:

Step d. _____

Step f. _____

- e. Raise the actuator assembly (AA) approximately another 1/2 inch (13 mm).
 - f. Continue, as recorded in Step d. above, the disengagement of the plug/stem (3). Count the number of revolutions until disengagement and record in the previous box (Step f.) **NOTE:** Take care to not "drop" the plug/stem (3) downwards to the body's (1) integral seat; lower slowly to this position.
6. **For ATC-FO (Direct) Action Units - Model 30D Actuator**

- a. Observe position/orientation of position indicator disc (20) and positioner accessory plate (AP) secured by stem jam nut (17).
- b. Place wrench on upper jam nut (17) and on adaptor (73) hex surfaces.
- c. Loosen upper stem jam nut (17) by rotating CCW (viewed from valve body end) approximately 1/2 inch (13 mm). Keep count of the number of revolutions to disengage the plug/stem (3) in the following box for Step c.:

No. of revolutions to disengage plug/stem from actuator stem:

Step c. _____

Step e. _____

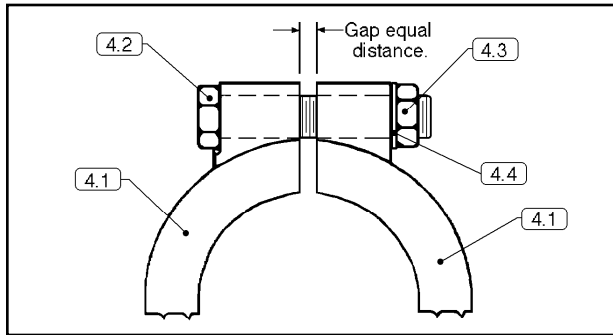

Figure 5: Clamp Arrangement

16. Wrench-tighten each clamp nut (4.3) in one-half revolution increments in a cross-pattern. Final tighten clamp bolting (4.2)(4.3) to a 20 ft-lbs (27 N-M) torque level.
17. Reinstall actuator assembly (AA) per Section V.B.8. and 9. herein.

D. Separation of Body/Actuator using Opt-68 Quick Disconnect Stem.

1. For ATO-FC (Reverse) Action Units-Model 30R Actuator

- a. Raise the actuator assembly (AA) approximately 1/2 inch (13mm). (**Note:** This step is not required for ATC-FO (Direct) Action Units with Model 30D Actuator.)
- b. The valve stem (3.1)-to-actuator stem assembly (23) is a quick disconnect joint. Grasp plug stem (3.1) between thumb and forefinger of one hand. Grasp the collar (80.2) between the thumb and forefinger of the other hand. Slide/push collar (80.2) upwards. Stems (3.1) and (23) should uncouple. Lower stem (3.1) until self supporting.
- c. Continue lifting actuator assembly (AA) upwards until able to swing out of the way and set down onto work surface.
- d. To reassemble the actuator assembly (AA) to the valve body assembly (BA), place body into a vise securely with the stem (3.1) directed upwards.
- e. Using an overhead hoist, rig and lift the actuator assembly (AA) above the body assembly (BA). Lower the actuator assembly (AA) down and over the valve stem (3.1), so that the stem (3.1) upper end passes through yoke nut (8), and the lower opening of the yoke (1). Continue lowering actuator assembly (AA) until the valve stem (3.1) is within 1/4 inch (6mm) of the actuators quick disconnect (80) end.

- f. Grasp valve stem (3.1) between thumb and forefinger of one hand. Grasp collar (80.2) between thumb and forefinger of the other hand. Lift stem's (3.1) upper end up and into the opening of the actuator stem (23) assembly. Slide/push the collar (80.2) upwards while simultaneously lifting the stem (3.1) end into the actuator stem (23) assembly. A "click" will be felt when the engagement is proper; release the collar (80.2). The lower lips of the collar (80.2) and the actuator stem (23) assembly should align. Release the stem (3.1) to ensure engagement.
- g. Position actuator assembly (AA) until alignment is correct with the matchmarks of V. B. 2 previous. Hand-tighten yoke nut (8).

2. For ATO-FC (Reverse) Action Units with Model 30R Actuator.

- a. Provide a temporary air supply to the actuator to allow pressurization to at least give 1/2 of the valve's full stroke.
- b. Fully lower actuator assembly (AA) down until the yoke (1) is sitting directly on the bonnet (2).
- c. Hand-tighten yoke nut (8) until tight by rotating CW (viewed from actuator end). Then rotate yoke nut (8) 1/2 revolution CCW (loosen).
- d. Release air pressure of Step a. above; valve plug (3) should come down to seat in body (1). Wiggle actuator assembly (AA) to help the alignment of plug (3), body (1) and bonnet (2).

3. For ATC-FO (Direct) Action Units with Model 30D Actuator

- a. Provide a temporary air supply to the actuator to allow pressurization to at least give the valve full stroke. Valve plug (3) should come down to seat in body (1). Wiggle actuator assembly (AA) to help alignment of plug (3), body (1), and bonnet (2).
- b. Wrench tighten yoke nut (8) by rotating CW (viewed from actuator end) until tight. Impact tighten yoke nut (8) using a blunt end tool and hammer.
- c. Release air pressure to actuator if pressurized.

- d. Loosen vise securing body (1). Using overhead hoist, lift and swing unit onto a work surface, taking care not to damage surfaces of end connections.
- e. Recalibration of actuator-to-positioner should not be necessary unless a differ-

ent body assembly (BA) was installed, or a different actuator assembly (AA) was installed. However a calibration check is still recommended. **NOTE:** *There is no calibration of body to actuator with the quick disconnect stem connector.*

SECTION VI

VI. CALIBRATION

A. General:

1. This section only covers calibration of the control valve unit - Actuator Model 30 plus a Model SCV-S body.
2. Positioner, if installed, requires reference to the specific positioner model IOM for proper calibration procedure.
3. All indicated items numbers that are with respect to IOM-30 will be in parenthesis and underscored; i.e. (20); the same is true for the positioner parts. All item numbers that are with respect to this IOM-SCV-S are not underscored; i.e. (3).
4. **NOTE: The following procedures based on use of standard adaptor (73) rather than Opt-68 Quick Disconnect Stem Connector. When Opt.-68 is supplied, no calibration is required.**

B. Procedure - Reverse Action, ATO-FC:

1. Provide a temporary air supply with an in-line adjustable airset regulator to the actuator top works connection. Do not LOAD with any air pressure.
2. Valve plug (3) should be in "closed" or "shut" position. Loosen screws (22) and position the indicator plate (21) at "S" (for "shut"); tighten screws (22) to secure indicator plate (21). **NOTE:** *Set the indicator plate (21) at the top edge of the indicator disc (20).*
3. Reference the nameplate (12) attached to the actuator yoke (1). Determine the bench setting of the installed range spring (6) from the nameplate (12); i.e. 4-15 psig (.28 -1.03 Barg), or 7-28 psig (.48-1.93 Barg).
4. Pressurize the actuator to a pressure level 2-3 psig (0.1-0.2 Barg) above the upper pressure level of the bench setting; i.e. for 4-15 psig (.28 -1.03 Barg) range, set pressure at 17-18 psig (1.2-1.3 Barg).

5. Observe the position of the indicator disc (20) and the indicator plate (21) making sure to use the "top edge" of the indicator disc (20) as the reference point. If the position indicated is not exactly at "O" (for "open"), then the valve stem (3)-to-actuator stem (23) combined length is incorrect and must be adjusted.
6. a. If travel goes beyond the "O" (for "open") position, the combined stem (3, 23) is short. Loosen both jam nuts (17) holding the travel indicator disc (20) against adaptor (73).
b. Increase combined stem (3, 23) length by rotating plug/stem (3) CCW (viewed from valve body end) a distance equal to the amount of over-travel.
7. a. If travel comes below the "O" position, the combined stem (3, 23) length is long. Loosen both jam nuts (17) holding the travel indicator disc (20) against adaptor (73).
b. Decrease combined stem (3, 23) length by rotating plug/stem (3) CW (viewed from valve body end) a distance equal to the amount of under-travel.

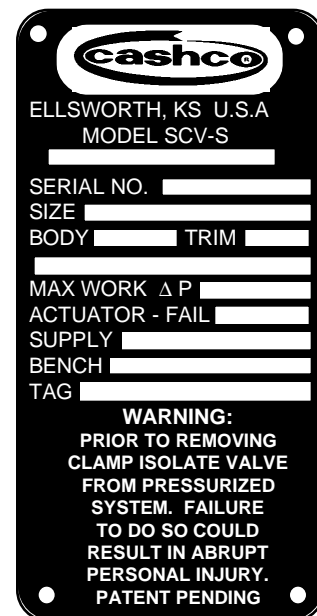

8. Readjust the indicator plate (21) to the indicator disc (20) so they align at the "O" (for "open") position.
9. Release air pressure in actuator allowing valve stem (3) to travel to the "closed" or "S" (for "shut") position. Check the position indicated on the indicator plate (21).
10. If the "S" (for "closed" or "shut") position is not correct, repeat Steps 6 through 9 above until the combined stem (3, 23) length is correct.
11. Tighten both jam nuts (17).
12. Pressurize the actuator to a pressure level corresponding to the lower pressure level of the bench setting; i.e. for 4-15 psig (.2-1.03 Barg) range, set pressure at 4 psig (.2 Barg). Do the pressurization slowly while observing the indicator disc (20) and indicator plate (21) simultaneously.
13. The proper calibration of the actuator/valve unit will occur when at the lower pressure level of bench setting, the valve plug (3) will just begin to travel from the closed position.

If calibration of stroke length is required, remove screws (15) and dust cover (14) on actuator assembly (AA) top.

Pressurize actuator slowly. If plug (3) begins travel before reaching the lower pressure level of bench setting, then increase the actuator's range spring (6) compression by wrench tightening spring adjustor (4) CCW (viewed from actuator end) in 1/4 revolution increments until desired bench setting is reached.

Pressurize actuator slowly. If plug (3) begins travel after surpassing the lower pressure level of bench setting, then reduce the actuator's range spring (6) compression by wrench loosening spring adjustor (4) CW (viewed from actuator end) in 1/2 revolution increments until desired bench setting is reached.

14. Increase pressure to actuator up to the upper level of bench setting and observe valve plug (3) position at the indicator plate (21). The valve plug (3) should be within $\pm 8\%$ (of full "stroke") of the "O" (for "open") position of the indicator plate (21). ("Stroke" length is indicated on the nameplate (12), and is the distance between the "S" and "O" points of the indicator plate (21).)

15. Record here the theoretical and actual pressure levels of paragraphs 13 and 14:

Theoretical	_____	psig
Bench Setting from Nameplate	_____	Barg
Setting at "S" Position	_____	psig
	_____	Barg
Setting at "O" Position	_____	psig
	_____	Barg

16. Replace dust cover (14) and secure with screws (15).

C. Procedure - Direct Action, ATC-FO:

1. Provide a temporary air supply with an in-line adjustable airset regulator to the actuator top works connection. Do not LOAD with any air pressure.
2. Valve plug (3) should be in "Open" position. Loosen screws (22) and position the indicator plate (21) at "O" (for "open"); tighten screws (22) to secure indicator plate (21). **NOTE:** Set the indicator plate (21) at the top edge of the indicator disc (20).
3. Reference the nameplate (12) attached to the actuator yoke (1). Determine the bench setting of the installed range spring (6) from the nameplate (12); i.e. 4-15 psig (.28-1.03 Barg), or 7-28 psig (.48-1.93 Barg).
4. Slowly pressurize the actuator to a pressure level 1-2 psig (.07-.14 Barg) less than the upper pressure level of the bench setting; i.e. for 4-15 psig (.28-1.03 Barg) range, set pressure to 13-15 psig (.90-.96 Barg). Valve plug (3) should be nearly "shut" or "closed". Increase pressure slowly until plug (3) seats in body (1).
5. Observe the position of the indicator disc (20) and the indicator plate (21) making sure to use the "top edge" of the indicator disc (20) as the reference point. If the position indicated is not exactly at "S" (for "shut" or "closed"), then the valve stem (3)-to-actuator stem (23) combined length is incorrect and must be adjusted.

6. a. If travel goes beyond the “closed” or “S” position, the combined stem (3, 23) position, is short. Loosen both jam nuts (17) holding the travel indicator disc (20) against adaptor (73).
- b. Increase combined stem (3, 23) length by rotating plug/head (3) CCW (viewed from valve body end) a distance equal to the amount of overtravel.
7. a. If travel comes below the “closed” or “S” position, the combined stem (3, 23) length is long. Loosen both jam nuts (17) holding the travel indicator disc (20) against adaptor (73).
- b. Decrease combined stem (3, 23) length by rotating plug/stem (3) CW (viewed from valve body end) a distance equal to the amount of undertravel.
8. Readjust the indicator plate (21) to the indicator disc (20) so they align at the “O” (for “open”) position.
9. Release air pressure in actuator allowing valve stem (9) to travel the the “open” or “O” position. Check the position indicated on the indicator plate (21).
10. If the “O” (for “open”) position is not correct, repeat steps 6 through 9 until the combined stem (3, 23) length is correct.
11. Tighten both jam nuts (17).
12. Pressurize the actuator to a pressure level corresponding to the upper pressure level of the bench setting; i.e. for 4-15 psig (.2-1.03 Barg) range, set pressure at 15 psig (1.03 Barg). Do the pressurization slowly while observing the indicator disc (20) and indicator plate (21) simultaneously.
13. The proper calibration of the actuator/valve unit will occur when at the upper pressure level of bench setting the valve plug (3) will just begin to travel from the closed position with a slight decrease in pressure.

De-pressurize actuator slowly. If plug (3) begins travel before reaching the upper pressure level of bench setting, release all air pressure, then increase the actuator’s range spring (6) compression by wrench tightening spring adjustor (4) CCW (viewed from actuator end) in 1/4 revolution increments until desired bench setting is reached. Repeat this procedure until desired bench setting is reached.

De-pressurize actuator slowly. If plug (3) begins travel after surpassing the upper pressure level of bench setting, release all air pressure, then reduce the actuator’s range spring (6) compression by wrench loosening spring adjustor (4) CW (viewed from actuator end) in 1/4 revolution increments until desired bench setting is reached. Repeat this procedure until desired bench setting is reached.

14. Decrease pressure to actuator down to the lower level of bench setting and observe valve plug (3) position at the indicator plate (21). The valve plug (3) should be within $\pm 8\%$ (of full “stroke”) of the “S” (for “shut” or “closed”) position of the indicator plate (21). (“Stroke” length is indicated on the nameplate (12), and is the distance between the “S” and “O” points of the indicator plate (21).)

15. Record here the theoretical and actual pressure levels of paragraphs 13 and 14:

Theoretical	_____	psig
Bench Setting		
from Nameplate	_____	Barg
Setting at “S”	_____	psig
Position	_____	Barg
Setting at “O”	_____	psig
Position	_____	Barg

SECTION VII

VII.TROUBLE SHOOTING GUIDE

1. Unit can not pass enough flow.

Possible Cause	Remedy
A. Sizing data not correct; valve undersized.	A1. Check actual pressures, temperature, and flow rates against the variables used for sizing. Recalculate Cv Required. A2. Replace unit with larger body size.
B. Obstruction at inlet.	B. Remove valve from line and inspect for something causing blockage.

2. Unit can not control steadily at low flow rates.

Possible Cause	Remedy
A. Sizing data not correct; valve oversized.	A1. Check actual pressures, temperature and flow rates against the variables used. A2. Replace full port body with reduced port body.
B. Obstruction at inlet.	B. Remove valve from line and inspect for something causing blockage.
C. Too short of "stroke".	C. Remove unit and calibrate.
D. Excess pressure drop.	D1. Check actuator bench setting; re-calibrate as required. D2. Check design pressures against actual pressures. Replace "low" bench set range springs with higher bench set range springs.
E. Insufficient IAS pressure.	E. Provide required level of IAS pressure.

3. Valve body leaking at clamped end connection joints.

Possible Cause	Remedy
A. Excess pressure levels.	A. Check actual pressures against those indicated in technical bulletin. Reduce pressures as necessary.
B. Loose clamp.	B. Remove valve from service. Disassemble and clean. Reassemble and properly tighten all clamps at reinstallation.
C. Excessive piping stress.	C. Place hanger on control valve unit.
D. Improper pipe alignment.	D. Re-do piping properly.

4. Fluid leakage at bonnet or at upper stem seal ring.

Possible Cause	Remedy
A. Gasket failure.	A1. Remove body, disassemble, remove old gasket. Install new gasket, new stem seals, reassemble and reinstall. A2. Seal ring failure.
B. Overheating	B. Ensure that max. operating temperature of 366°F (186°C) is not exceeded.)
C. Stem seal failure	C1. Worn stem seals. Replace seals and gasket. C2. Pitted stem, worn stem. Replace plug/stem, seals and gasket.

5. Inadequate valve shutoff.

Possible Cause	Remedy
A. Permanent "tracks" where seating occurs.	A1. Replace body and plug/stem. A2. Recondition body and plug/stem.
B. Excess valve pressure drop.	B. Reduce valve's shutoff pressure drop.
C. Insufficient IAS pressure.	C. Provide required level of IAS pressure.
D. Obstruction at seat.	D. Remove body and inspect for obstruction.
E. Improper calibration.	E. Recalibrate positioner and valve stroke.
F. Improper actuator bench set range.	F. Disassemble actuator and change to stiffer range springs. Reinstall and increase IAS to proper level.

6. Unit will not operate.

Possible Cause	Remedy
A. IAS is "off".	A. Turn "on" the IAS and set at proper level.
B. Faulty positioner.	B. Service positioner or replace.
C. Improper positioner action.	C. Switch positioner to proper action unit.
D. Actuator has a leak.	D. Manually load actuator to test for pressure integrity. Replace diaphragm and O-ring if either is leaking.

7. Instability.

Possible Cause	Remedy
A. Insufficient dampening.	A. Recalibrate and set dampening adjustment of positioner.

SECTION VIII

VIII. PARTS ORDERING INFORMATION

To obtain parts ordering information/numbers, utilize one of the following methods. The least expensive method is to utilize parts in kits where possible.

METHOD A – USE OF BILL OF MATERIAL

- Step 1. If available, obtain the 18 character product code number from the Bill of Materials sheet attached herein. (Confirm that it duplicates the 18-digit product code stamped on valve's metal name plate.)
- Step 2. Identify which parts are desired from the BOM sheet – reference the cross-sectional drawings.
- Step 3. Contact your local Cashco, Inc., Sales Representative and specify the product code number, and any part number(s) desired. Cost of parts can be given by the Sales Representative.

METHOD B – USE OF VALVE'S SST NAME PLATE

- Step 1. Obtain all available information from valve's metal tag.
- 18-Character product code.
 - Serial number.
 - Line size and port size.
 - Max. Work ΔP .
 - Fail Position
 - Supply pressure.
 - Bench Range
- Step 2. With the information from Step 1, contact your local Cashco, Inc., Sales Representative who will confirm with the factory to determine the original internal construction.
- Step 3. Factory will relay information to the Sales Representative who will advise you with correct part numbers and prices.

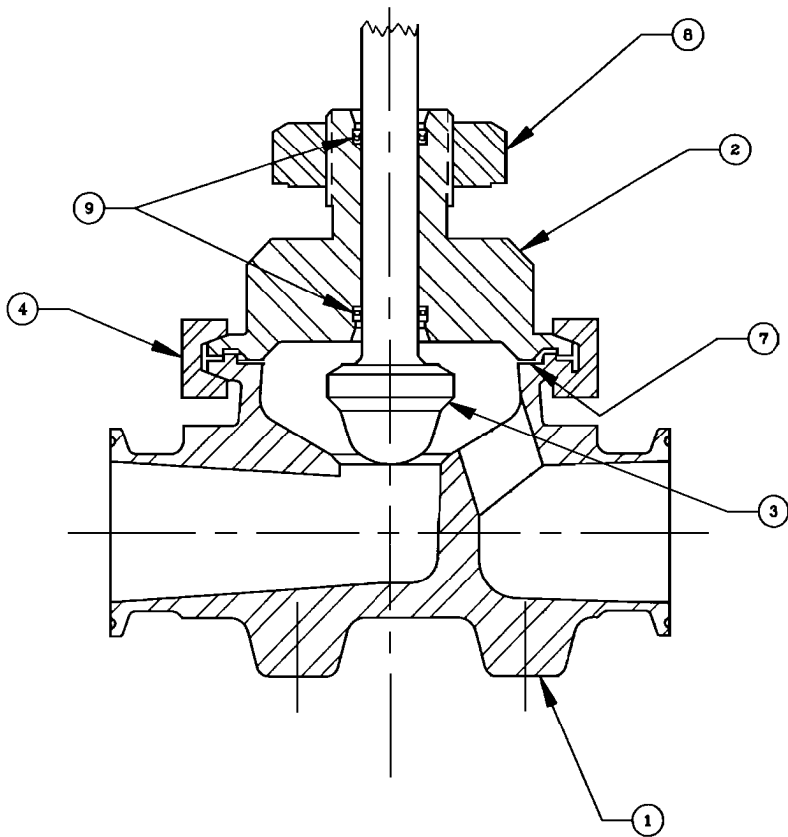

ITEM NO.	DESCRIPTION
1	Body
2	Bonnet
3	Plug
4	"Tri-Clover" Clamp
7	Gasket
8	Yoke Nut
9	Seals

FIGURE 6:
Body Assembly (BA), Straight-Globe

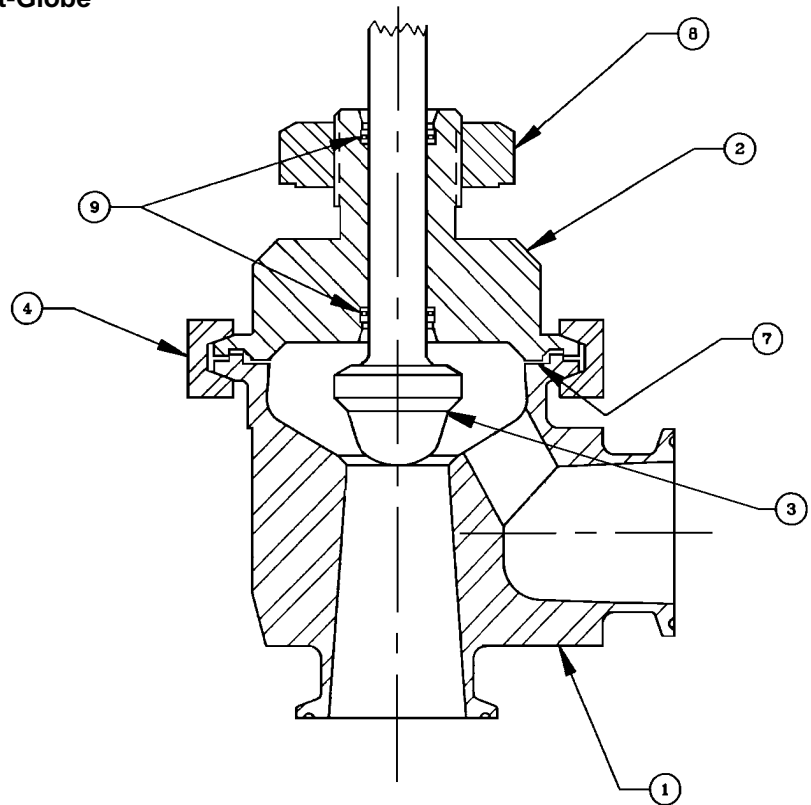

ITEMS NOT SHOWN

ITEM NO.	DESCRIPTION
5	Flow Arrow Tag
6	Drive Screw

FIGURE 7:
Body Assembly (BA), Angle-Globe