



MODEL 764T

PNEUMATIC TEMPERATURE CONTROLLERS

SECTION I

I. DESCRIPTION AND SCOPE

The Model 764T is a temperature controller with integral, rigid insertion bulb used for sensing temperature, and outputting a pneumatic signal proportional to the deviation from the setpoint.

This IOM-764T does not cover use of oxygen as the "instrument air" fluid. Such an application is outside the scope of this IOM.

With proper materials and pipe sizes, the 764T can be used to measure the temperature of liquid, gaseous, or vapor service. The installation of the thermal bulb can be direct or indirect using a thermal well. Refer to Technical Bulletin 764T-TB for design and selection recommendations.

Abbreviations Utilized:

IAS - Instrument Air Supply
SIG - Signal
P/P - Pneumatic-to-Pneumatic
TC - Temperature Controller
TI - Temperature Indicator
SRV - Safety Relief Valve

ES - Electrical Supply
TCV - Temperature Control Valve
P1 - Inlet Pressure
P2 - Outlet Pressure
TR - Condensate Trap
PB - Proportional Band

CW - Clockwise
CCW - Counter Clockwise
REV - Revolution or Reverse
DIR - Direct
FS - Flow Switch
SOV - Solenoid Valve

SECTION II

II. INSTALLATION

1. Location of the thermal bulb into the medium being controlled is critical.
 - a. Always insert the maximum bulb length into the medium.
 - b. Always locate the bulb at a point downstream of a heat exchanger to assure a near-equal distribution of the temperature across the containment cross-section.
 - c. Always locate the control valve doing the temperature control no further than 6-10 feet (2-3 meters) away from the controller when the control valve does not have a positioner.
 - d. Do not use a thermal well unless the Owner's process conditions, safety considerations or maintenance procedures require such; a thermal well enters an extra time response delay (i.e. reduction in sensitivity) to the closed loop.
 - e. If a thermal well is required, to maximize heat transfer efficiency, locate on the top of a pipe (vertical or at a 45° angle), duct, or at a 45°

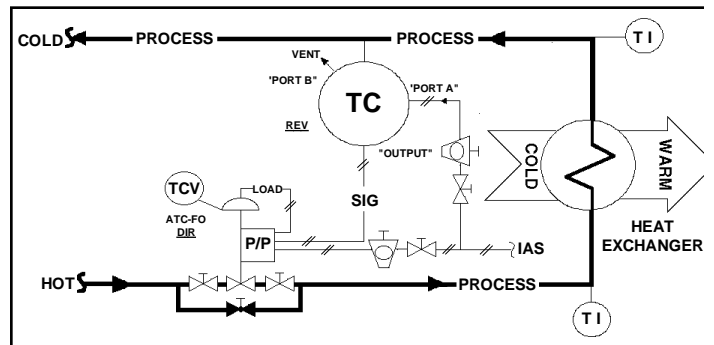

Figure 1: Typical Direct Cooling Application

- f. If a thermal well must be installed in a horizontal orientation, attempt to "pack" the "void space" with steel or SST wool at bulb insertion. Use of the well packing will increase thermal efficiency (reduce time constants) above that of a "dead air" space in the "void space"; i.e. dead air space acts as an "insulator" to heat transfer.

- g. Indoors, controllers without a thermal well may be oriented in any position.
- h. Outdoors, controllers without a thermal well should be mounted with the main longitudinal axis horizontal or below. Make sure that the vent port (either A or B) will not take in rainwater; use an angle fitting, if necessary.
- i. Indoors, controllers with a thermal well should be mounted as recommended in Article 1.e.
- j. Outdoors, controllers with a thermal well should be mounted at a 45° angle to main pipe or duct axis, when possible. Make sure that the vent port (either A or B) will not take in rainwater; use an angle fitting if necessary. The controller can be installed at any angle below 45° at reduced thermal sensitivity.

2. As the indicator dial of a 764T only acts to give an approximate temperature setpoint, it is recommended that a thermometer be installed very near the location of the 764T. If the 764T utilizes a thermal well, then the thermometer should also use a thermal well. If the 764T does not use a thermal well, then the thermometer should not use a thermal well.
3. Recommended pipe tap size is 1/2" NPT for a thermal bulb without a thermal well.
4. Recommended pipe tap size is 3/4" NPT for a thermal bulb with a thermal well.
5. If the pipe tap size is greater than the size required by either the thermal bulb or thermal well, a pipe bushing fitting is recommended rather than bell reducers to bring the tap size to that required.

6. Use suitable pipe thread sealant when installing a thermal well or a 764T thermal bulb.

CAUTION: When engaging the threaded bulb connection into its coupling or thermal well, **DO NOT GRASP THE PNEUMATIC HOUSING OR KNURLED LOCK NUT AND MANUALLY ROTATE THE CONTROLLER; ONLY USE A WRENCH (1-3/8") AND TIGHTEN AT THE HEX SURFACE PROVIDED!!** Failure to comply may cause the factory-set calibration to be altered, requiring shop recalibration. Rotate the unit CW (viewed from housing end) to engage threads.

7. Clean the piping and tubing of all foreign materials including chips, burrs, dirt, etc. prior to use. Use care in applying thread sealant or TFE tape to prevent excess material from entering the flow path.

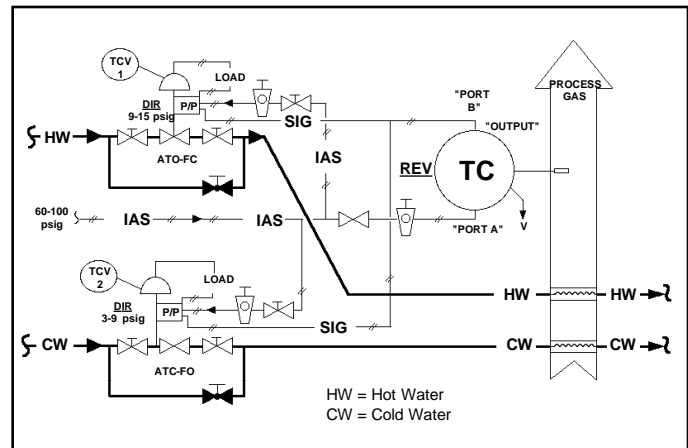

Figure 3: Alternating Heating/Cooling System with Split-Range Pneumatic (P/P) Positioners- "Fail" to Cooling Mode on Loss of Air Supply

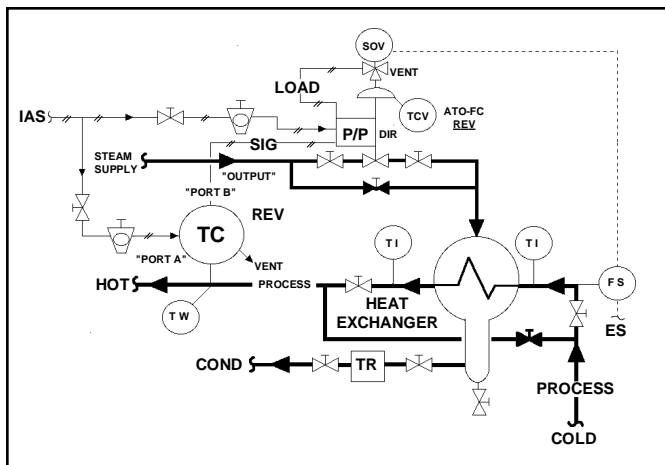

Figure 2: Typical Indirect Heating Application

8. **KEEP CANTILEVERED PIPE, AIRSET, OR OTHER APPURTENANCES TO A MINIMUM.** It is recommended that the airset supplying instrument air be independently mounted elsewhere and tubed to the controller. Failure to comply with this recommendation may result in the eventual loosening of the housing from the thermal bulb, causing the unit to go out of calibration.
9. Connect piping/tubing per Tables 1 and 2. Do not plug or restrict the open (unused) port (A or B) vent connection. Port "A", Port "B" and "OUTPUT" are identified on the housing casting.
10. 764T's can operate with a lubricated, non-dried air supply; however, good practice and other system components (airsets, positioners, relays, etc.) require the use of the highest quality air supply available; i.e. non-lubricated compressed air source and desiccant dried air.

TABLE 1

Controller	Model 764T	
IAS to Port	Action	
	Direct	Reverse
A	Exhaust	Supply
B	Supply	Exhaust
PROCESS TEMPERATURE	Increase in temperature <u>increases</u> output signal.	Increase in temperature <u>decreases</u> output signal.

11. Instrument air exposed to outdoor freezing temperatures must be desiccant dried. Refrigerated drying is not adequate.
12. Instrument air exposed to indoors and/or no-freezing temperatures is recommended to be refrigerant dried as a minimum.
13. If the air supply is at a remote location, and can not be practically dried and bears oil (i.e. plant air), coalescing filters must be utilized to remove as much oil and water as possible, as well as particles over 15 microns size.

TABLE 2

Controller	"Heating" Applications	
IAS to Port	Actions	
	Control Valve	Controller
A	ATO-FC (Reverse)	<u>Reverse</u> Increase in temperature decreases output signal. Valve "fails" to "cooler" process temperature.
B	ATC-FO (Direct)	<u>Direct</u> Increase in temperature increases output signal. Valve "fails" to "hotter" process temperature.
	"Cooling" Applications	
	Actions	
B	ATO-FC (Reverse)	<u>Direct</u> Decrease in temperature decreases output signal. Valve "fails" to "hotter" process temperature.
A	ATC-FO (Direct)	<u>Reverse</u> Decrease in temperature increases output signal. Valve "fails" to "cooler" process temperature.

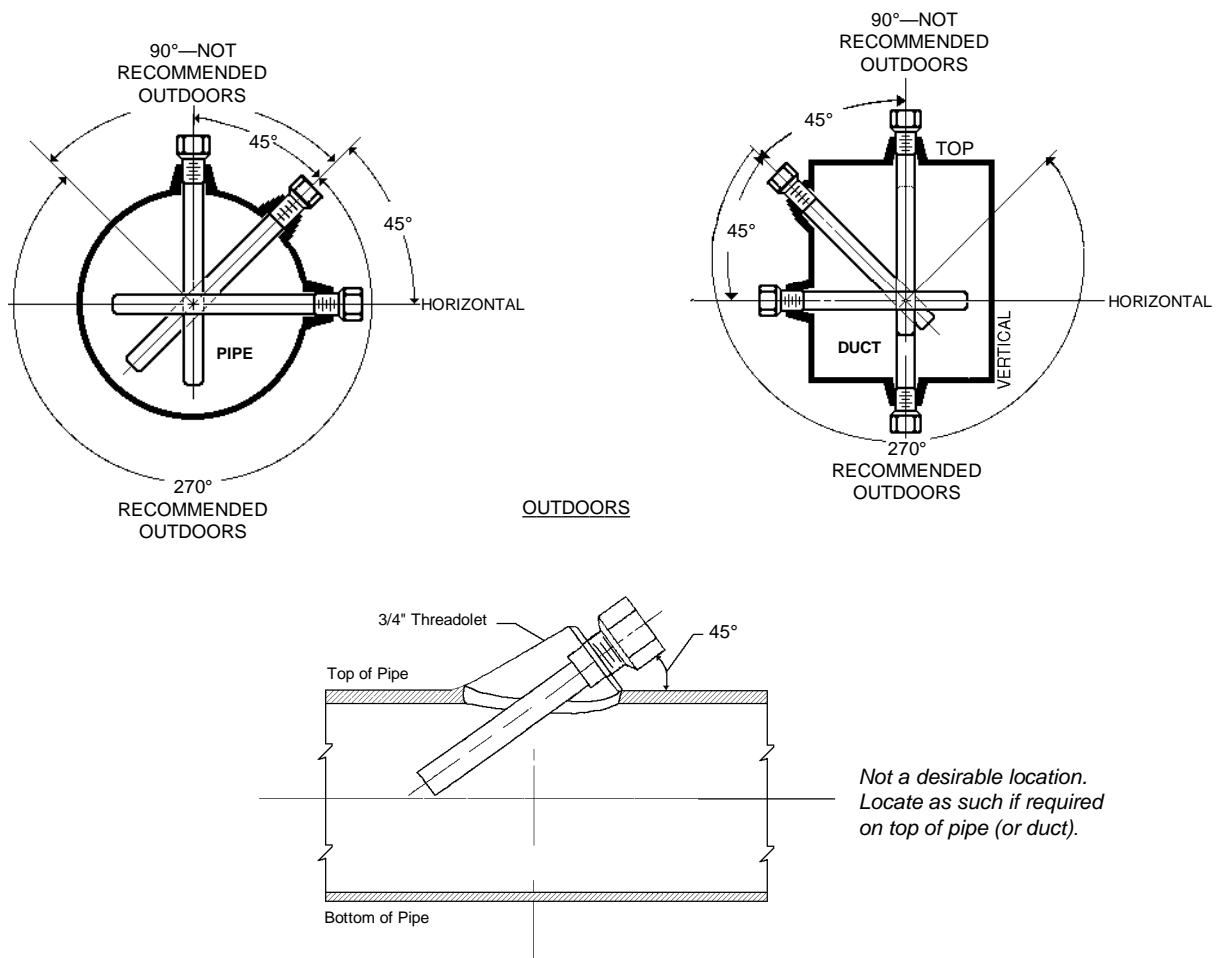

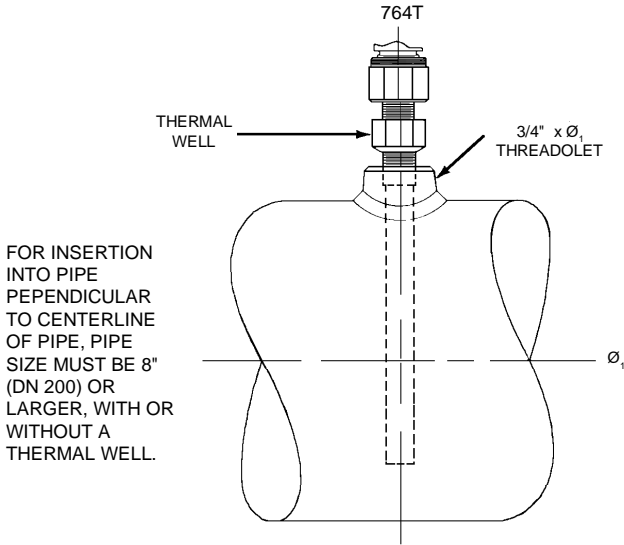

(a): Pipe 8" (DN 200) ϕ & Larger

ϕ_1		ϕ_2		Nipple Length L_2	
Inch	(mm)	Inch	(mm)	Inch	(mm)
1/2"	(DN 15)	1"	(DN 25)	6"	152
3/4"	(DN 20)	1-1/4"	(DN 32)	6"	152
1"	(DN 25)	1-1/4"	(DN 32)	6"	152
1-1/4"	(DN 32)	1-1/2"	(DN 40)	6"	152
1-1/2"	(DN 40)	2"	(DN 50)	6"	152
2"	(DN 50)	2"	(DN 50)		NR
2-1/2"	(DN 65)	2-1/2"	(DN 65)		NR

NR = Not Required

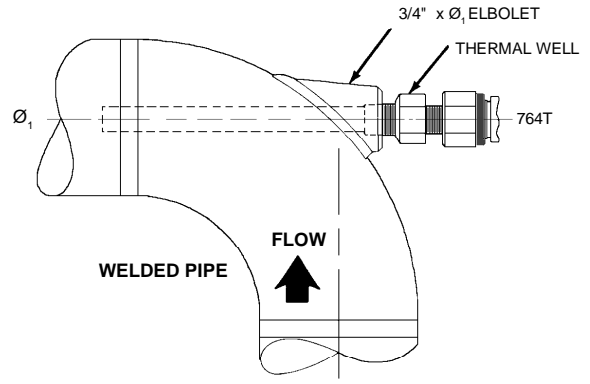

(b): Req'd: 2-1/2" (DN 65) Thru 6" (DN 150)
Optional: 8" (DN 200) or Larger

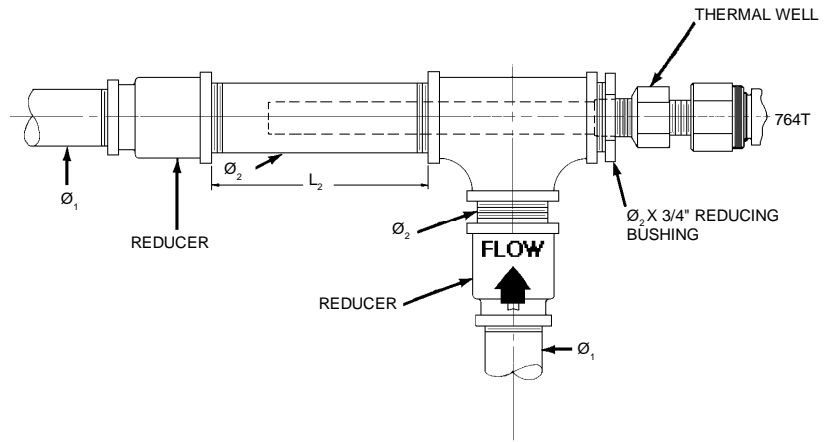

(c): Thru 2-1/2" (DN 65) Screwed Pipe Sizes.

Figure 5: Recommended Thermal Well (Opt. 64) Installation

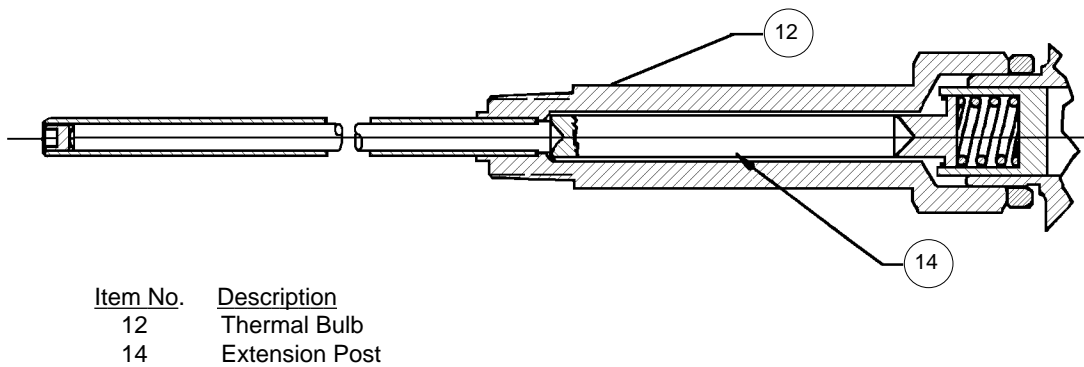

Figure 6: High Temperature Thermal Bulb (Opt. 63)

SECTION III

III. PRINCIPLE OF OPERATION

1. The 764T controller employs laminar flow to develop the 3-15 psig (nominal 0.2 - 1.0 Barg) output signal. Laminar flow was chosen because it eliminates the need for range springs, levers, pivots and other parts that produce friction and lost motion.
2. A bimetallic thermal bulb is used to measure temperature. It is immersed in the fluid whose temperature is to be controlled. A temperature variation changes the length of the outer tube more than it changes the length of the Invar rod. This difference produces a minut movement of the end of the Invar rod that contacts the sensor plate. The sensor plate, in turn, throttles the flow of instrument air through the sensor to develop the 3-15 psig (0.2 - 1.0 Barg) output signal.
3. On direct acting controllers, see Figure 7, the supply enters PORT B. With an increase in the sensed temperature the supply air flowing through the sensor orifice increases, which elevates the output signal. The proportional band restriction regulators the flow of exhaust through PORT A.
4. On reverse acting controllers the supply enters PORT A and passes through the proportional band restriction. With an increase in the sensed temperature the flow through the sensor orifice is increased, which reduces the output signal. PORT B is the exhaust port.
5. Closing the proportional band adjusting screw reduces the proportional band. Opening the screw increases the proportional band.
6. The setpoint adjustment moves the sensor closer to, or further away from, the sensor plate to change the controlled temperature.

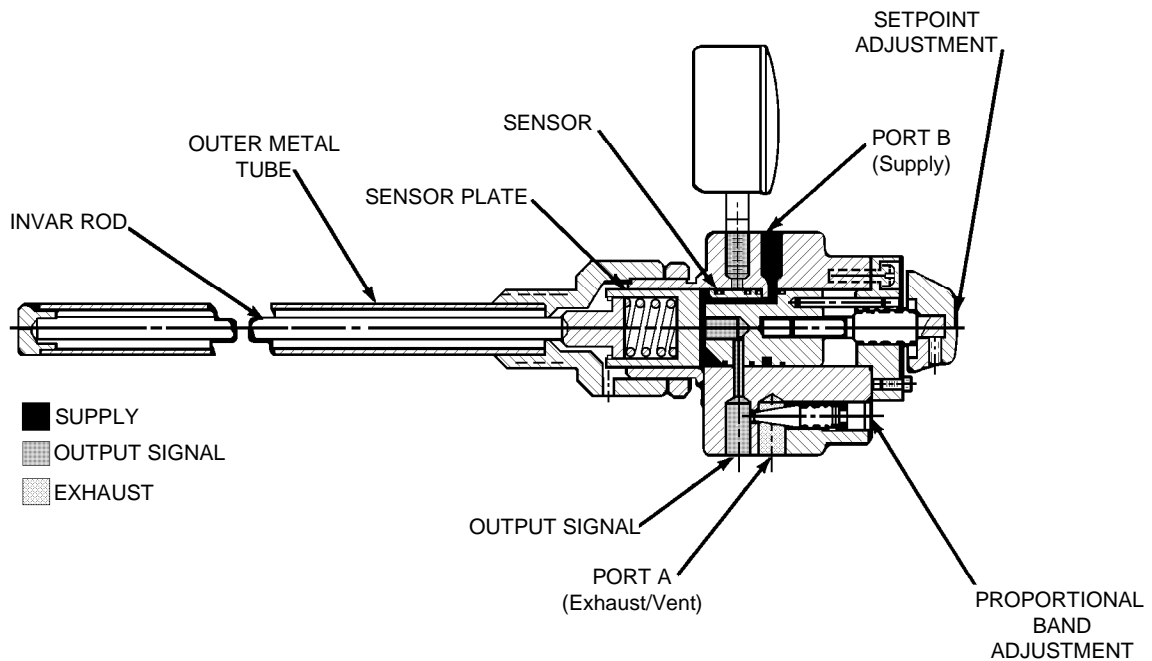

Figure 7: 764T Direct Action View Shows Port A & B Rotated From Actual Position

SECTION IV

IV. START-UP

1. Prior to pressurizing thru the airset, disconnect the IAS at the airset inlet, open the IAS block valve and air-blow the supply piping/tubing to clear of any debris, moisture, etc. Re-connect to the airset.
2. Disconnect IAS tubing at the 764T, open the IAS block valve at the airset and air-blow. Repeat for IAS to the positioner, if supplied.
3. Set airset to 18 psig (1.24 Barg) outlet pressure. Blow down the airset dripwell.
4. Establish flow past the bulb, allowing the bulb to "sense" the actual temperature.
5. It is recommended that the control valve that receives the output SIG of the 764T be manually isolated at "cold" start-up. To prevent initial temperature overshoot/undershoot while the system reaches thermal stability, initiate flow in the control valve loop by manually bypassing.
6. Observe actual temperature of the fluid being temperature controlled utilizing a separate thermometer instrument. As the control temperature approaches the "setpoint" temperature, begin to manually close the control valve bypass. Attempt to establish steady-state manual control. **NOTE:** *It may take a time frame of 15 minutes or greater to establish any level of steady-state manual control; DO NOT MOVE TOO FAST!*
7. Observe the action of the control valve in response to the action of the 764T temperature controller. Confirm that the proper combined "loop action" is occurring. If not correct, review the required action desired, and reverse action of either the control valve or 764T. To reverse action of a 764T, the IAS to the 764T must be removed from the "as installed" 764T port, and re-connect in reverse; i.e. if IAS was installed to Port "B", change to Port "A", and vice versa. (See Tables 1 and 2).

NOTE: *The 764T is factory calibrated to approximately mid-range; i.e. a 50-220°F (10-104°C) temperature range will have setpoint at approximately 135°F (57°C). It is recommended that the unit be shop calibrated, if required, in the field. Field calibration is, in most cases, not practical. See Section VI.*

8. Adjust setpoint by rotating the setpoint knob (4) until the pointer of knob (4) indicates the desired temperature indicated on the temperature dial (10).

NOTE: *The temperature dial (10) will only give an approximation of the actual temperature, and may be inaccurate by $\pm 5\%$ scale. The PB and setpoint adjustments are "interacting", meaning that to change one will likely cause the other to have to change. With each of these adjustments, the temperature dial (10) and the pointer of the knob (4) may be growing apart, although the actual setpoint may not be changing. [If this setpoint deviation is objectionable, determine the deviation after all the adjustments have been completed on the 764T. Remove knob (4) by loosening set screw (4.1), remove dial screw (9), and remove temperature dial (10). Drill a new offset 1/8" (3 mm) hole with the deviation equal to the offset. Obtain a small flat washer to hold the dial (10), reinstall the dial (10) using the new hole, and reinstall the knob (4).]*

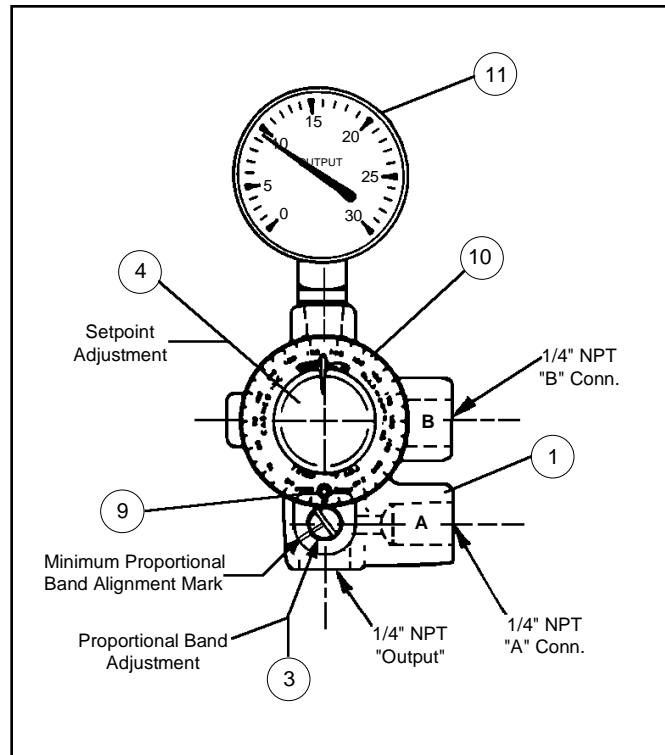

Figure 8: 764T End View

NOTE: *The 764T is shipped with the proportional band (PB) set at a minimum value of approximately 3%. Matchmarks are factory placed on the housing (1) and needle valve (3) head corresponding to the 3% PB value.*

CAUTION: *Do not rotate the needle valve (3) CW below the 3% PB value, as the unit will be rendered inoperative.*

9. Rotate needle valve (3) CCW approximately 1/4 of a full revolution; this corresponds to approximately 6% PB.

NOTE: *The needle valve (3) may be adjusted only 1-1/2 revolutions CCW from the initial 3% PB minimum value until the maximum 20% PB is reached. Do not rotate needle valve (3) beyond the 1-1/2" revolution limit.*

10. By observing the output SIG of the 764T as indicated on instrument gage (11), and manually varying control valve bypass flow upwards and downwards, the setpoint can be confirmed as approximately the point where output SIG pressure is at 9 psig (0.62 Barg).
11. Increase or decrease 764T setpoint to drive the control valve closed. Remember the ΔT change adjusted.
12. Open the block valves isolating the control valve.
13. Begin to manually close the control valve bypass valve while simultaneously changing the 764T setpoint back towards the desired setpoint prior to Article 11, this section. Attempt to simultaneously

change the setpoint and further close the bypass in proportional increments; i.e. close the bypass about 10% while changing the setpoint by about 10% of the ΔT change of Article 11.

NOTE: *Many temperature control system loops have sizeable time constants; i.e. flywheel effect. Make adjustments in small increments and wait for the results to stabilize.*

14. If the control valve and 764T becomes unstable, leave the setpoint adjustment as is and increase PB adjustment by rotating needle valve (3) approximately 1/8 revolution CCW. Wait for results to stabilize.
15. Continue Articles 13. and 14. slowly until the control valve bypass valve is fully closed, and the 764T controller is regulating flow.
16. It is recommended that an "upset" be imposed onto the system, and observe the capability of the controller to stabilize the upset. If instability results, PB should be increased in 1/8 CCW revolutions until stability is within the 764T's capability.

SECTION V

V. MAINTENANCE

A. General:

1. Refer to Figure 10 for cutaway view of 764T temperature controller and Figure 6 for cutaway view of the high temperature thermal bulb with extension post (Opt. -63).
2. Maintenance procedures hereinafter are based on removal of the controller with the thermal bulb (12) as a unit from the thermal well (17) or piping system.
3. When removing the tubing to/from the controller, tag the tube utilized with either Port "A" or "B".
4. There is no maintenance performable to the thermal well (17) for the controller. If the thermal well (17) is corroded, a liquid pressure test may be performed at the following maximum pressure levels:

SST Thermal Well —9,300 psig (641 Barg)
Brass Thermal Well —1,500 psig (103 Barg)
5. There is no maintenance performable to the thermal bulb (12) portion of the controller. If

the thermal bulb (12) is corroded, a liquid pressure test may be performed at the following maximum pressure levels to assure pressure integrity.

SST Thermal Bulb — 9,300 psig (641 Barg)
Brass Thermal Bulb — 1,500 psig (103 Barg)

6. Lightly grease all O-rings upon replacement with lithium grease; cloth wipe all excess grease.
7. Place thermal bulb (12) into a vise and grip on the hex surfaces of the thermal bulb assembly (12). Orient the pneumatic section upwards.

B. Pneumatic Circuit Overhaul:

1. Remove output pressure gage (11) and test calibration. If gage (11) is off ± 2 psi (± 0.14 Bar), replace gage (11).
2. Using channel lock pliers or similar tool, loosen knurled lock nut (16) by rotating CCW (viewed from knob (4) end). Back lock nut (16) away from thermal bulb (12) until it is stopped by contact with the sensor housing (1). Keep track of the number of revolutions loosened

2. (cont.) for lock nut (16) in table below:

Number of revolutions lock nut is "loosened" from thermal bulb: _____ Number of revolutions to remove housing from thermal bulb: _____

3. Place a marking on the temperature dial (10) at the point where the "tip" of the knob (4) is located. Remove knob (4) by loosening set screw (4.1) and lifting.
4. Remove temperature dial (10) by removing screw (9) and lifting.
5. Remove four sensor end plate screws (8).
6. Grasp sensor end plate (2.2) and withdraw vertically from housing (1). Lay sensor sub-assembly (see Figure 9) on work surface; take care to not lose sensor pin (2.4) in handling.
7. Hand-grasp housing (1) and rotate CCW (viewed from knob end) to removal. Keep track of the number of revolutions to removal in table of Step 2, previous. Take care not to invert and drop the sensor plate subassembly (15) from the housing (1) internals in handling.
8. Remove thermal bulb (12) from vise, taking care not to invert and drop Invar rod (13) (also extension post (14)) of the thermal bulb (12) and cause end damage to rod (13) (also post (14)). Examine bulb (12) interior for signs of leakage; recommend complete 764T replacement if leakage is discovered.
9. Holding the housing (1) in a vise, remove the sensor plate O-ring (6) using an awl-type tool, and discard. **DO NOT DAMAGE METAL SURFACES!**
10. Remove the housing (1) from the vise, invert housing (1) with hand covering knob-end to allow sensor plate subassembly (15) to drop/slide out of the housing (1); it may be necessary to push adapter (15.2) to remove the sensor plate subassembly (15).
11. Pick up sensor subassembly (2). Allow sensor pin (2.4) to be removed. Rotate sensor (2.1) CCW (viewed from sensor end) to removal. Keep track of the number of rotations to remove the sensor (2.1) from the adjusting screw (2.3) in the following table:

Number of revolutions to remove sensor from adjusting screw: _____ Number of revolutions to remove sensor end plate from adjusting screw: _____
--

12. Rotate sensor end plate (2.2) CCW (viewed from sensor end) to removal. Keep track of the number of rotations to remove the end plate (2.2) from the adjusting screw (2.3) in the table of Step 11.
13. Remove three O-rings (5) from sensor (2.1).
14. Pick up housing (1). Using a suitable screwdriver, rotate needle valve (3) CW until it seats. Keep track of the number of revolutions required to seat the needle valve (3) and record in table below:

Number of revolutions required to seat the needle valve: _____

15. Reverse the rotation of the needle valve (3) and fully remove. Remove needle valve O-ring (7).
16. Solvent clean and air blow all internal parts.
17. Install new O-rings on the needle valve (7), and three on sensor (5).
18. Place thermal bulb (12) back into a vise. Insert Invar rod (13) (also extension post (14)) into thermal bulb (12).
19. Re-assemble sensor subassembly (2) end plate (2.2), adjusting screw (2.3), and sensor (2.1) per the recorded number of revolutions of Step 11, this sub-section; this will give "preliminary" adjustment. See Figure 9 for "final" adjustment dimensions of the sensor subassembly (2). Rotate sensor (2.1) as

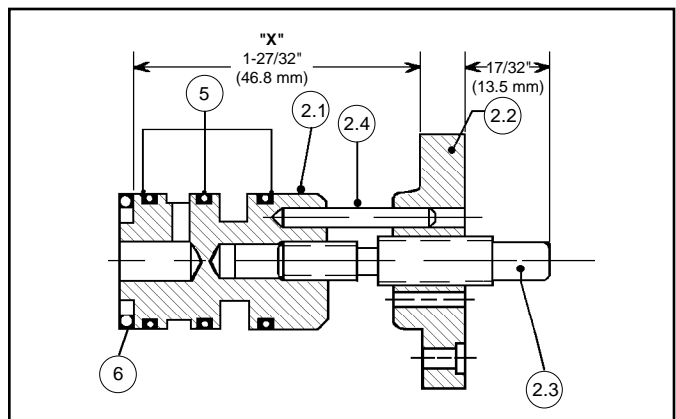

Figure 9: Sensor Sub-Assembly Dimensions
(Assemble per these instructions)

required to the closest hole available to allow sensor pin (2.4) to be inserted; insert pin (2.4). **(NOTE: A temporary piece of tape may be used to cover the hole the pin is inserted into, to prevent the pin from becoming lost.)**

20. Pick up housing (1) and insert sensor plate subassembly (15) back into the housing (1). Insert new sensor plate O-ring (6) up against the sensor plate (15.1).
21. Holding the housing (1) with the cavity upwards, re-insert sensor subassembly (2) into the housing (1) cavity. Push firmly until the sensor subassembly (2) end plate (2.2) reaches the mating face of the housing (1). **DO NOT FORCE INSERTION OF THE SENSOR SUBASSEMBLY (2). IF NOT CENTERED IN HOUSING (1) CAVITY, DAMAGE MAY OCCUR TO SENSOR O-RINGS (5)!**
22. Rotate sensor end plate (2.2) until the threaded hole for dial screw (9) is directly above the proportional band needle valve (3) opening. Holes should align for the four end plate screws (8); rotate as required. Insert screws (8) and fully tighten in a cross pattern.
23. (Remove temporary tape of Step 19 previous this sub-section.) Re-position temperature dial (10) onto sensor end plate (2.2) and align dial screw (9) hole; insert and tighten dial screw (9).
24. Insert housing (1) threaded end into thermal bulb (12), rotating the number of revolutions recorded in Step 2, this sub-section.
25. Rotate knurled locknut (16) the same number of revolutions recorded in Step 2, this sub-section. **NOTE:** Lock nut (16) should be nearly/already tight; if lock nut (16) is not tight, fully tighten. If more/less than 1/2 revolution of the number recorded in Step 2 is required to tighten lock nut (16), it is recommended that the housing (1) be removed from the bulb (12) and that Steps 24 and 25 be repeated.
26. Insert PB needle valve (3) into housing (1) and rotate CW until seated. Back out the needle valve (3) the number of revolutions recorded in table of Step 14, this sub-section.
27. Re-position the knob (4) back onto the adjusting screw (2.3) such that the notch in the adjusting screw (2.3) aligns with the knob set screw (4.1). Tighten knob set screw (4.1). Rotate knob (4) until the "tip" on the knob (4) is at the marking on the temperature dial (10) of Step 3, this sub-section; rotate the knob (4) the least amount to align to the marking.
28. Following the above procedure should bring the re-assembled unit "close" to the disassembled setpoint. Regardless, shop calibration is recommended.
29. Reinstall output pressure gage (1) using suitable pipe thread compound or teflon tape. **DO NOT APPLY EXCESS THREAD SEALANT!!**

SECTION VI

VI. SHOP CALIBRATION

1. The Model 764T is a "blind controller"; i.e. non-indicating. The temperature dial gives only an approximate actual setpoint temperature. When installed in the process each adjustment of the PB needle valve (3) and/or the knob (4) will affect the setpoint; i.e. the adjustments are inter-acting.
2. Install a 1/4" pipe plug in the "OUTPUT" port of the unit.
3. Provide an 18 psig (1.2 Barg) IAS to the proper port as determined by Table 1, Section II.
4. Leave PB as set in Section V.B.26.
5. Provide a known temperature bath that is equal to the desired setpoint temperature. The bath must be steady in its temperature.
6. Loosen knurled lock nut (16) 1-2 revolutions.
7. Insert the thermal bulb (12) such that it is immersed to the underneath side of the hex surface of the bulb (12). Place locking pliers on the hex surface of bulb (12) to hold firmly.
- 8.1. FOR DIRECT ACTION:
 - a. Set the "tip" of the knob (4) to the desired setpoint temperature.
 - b. If the output pressure gage (11) is at 15 psig (1.03 Barg) or more, decrease the setpoint temperature by holding the thermal bulb (12) locking pliers, and rotating housing (1) CW (viewed from knob-end) until the output pressure decreases to 9 psig (0.62 Barg).
 - c. If the output pressure gage (11) is at 0 psig (0.0 Barg), increase the setpoint temperature by holding the thermal bulb (12) locking pliers, and rotating housing (1) CCW (viewed from knob-end) until the output pressure increases to 9 psig (0.62 Barg).

- d. Using channel locking pliers, tighten knurled lock nut (16), to allow removal from the bath without the housing-to-thermal bulb joint changing with respect to each other.
- e. Place the thermal bulb into a vise and secure. Wrench tighten knurled lock nut (16) without allowing the housing (1) to "move".
- f. Re-insert the bulb (12) into the bath, and vary the position of the "tip" of the knob (4) a few degrees to cause the calibration setpoint to be repeated. If setpoint is in error, repeat Sub-Steps a. through f. until correct.

8.2. FOR REVERSE ACTION:

- a. Set the "tip" of the knob (4) to the desired setpoint temperature.
- b. If the output pressure gage (11) is at 15 psig (1.03 Barg) or more, increase the setpoint temperature by holding the thermal bulb (12) locking pliers, and rotating housing (1) CCW (viewed from knob-end) until the output pressure decreases to 9 psig (0.62 Barg).

- c. If the output pressure gage (11) is at 0 psig (0.0 Barg), decrease the setpoint temperature by holding the thermal bulb (12) locking pliers, and rotating housing (1) CW (viewed from knob-end) until the output pressure increases to 9 psig (0.62 Barg).
- d. Using channel locking pliers, tighten knurled lock nut (16), to allow removal from the bath without the housing-to-thermal bulb joint changing with respect to each other.
- e. Place the thermal bulb into a vise and secure. Wrench-tighten knurled lock nut (16) without allowing the housing (1) to "move".
- f. Re-insert the bulb (12) into the bath, and vary the position of the "tip" of the knob (4) a few degrees to cause the calibration setpoint to be repeated. If setpoint is in error, repeat Sub-Steps a. through f. until correct.

- 9. Remove plug of Step 2, and temporary IAS of Step 3.

SECTION VII

VII. TROUBLE SHOOTING GUIDE

- 1. No controller response.

Possible Cause	Remedy
A. Sensing thermal bulb loose at screwed connection to housing.	A. See remedy 5.A this section. Re-calibrate.
B. No air supply	B1. Check to see if air is available at airset. B2. Check to see if airset filter and/or dripwell is plugged.
C. Improper action; port "A" or "B" connections reversed.	C. Reference Tables 1 & 2 herein for desired action and proper port; reverse as required.
D. PB needle valve is fully closed.	D. Open at least to alignment of matchmarks on valve's screw head and housing.
E. Ice formation.	E. Use dry air as an IAS medium in cold weather. Thaw as necessary by use of air heater. Trace as necessary.
F. Final element operation problem; i.e. control valve, positioner, solenoid, etc.	F. Reference instructions for operation of final element.

- 2. Improper control valve action.

Possible Causes	Remedy
A. Mismatch of pneumatic hardware.	A. Check bench set of actuator. Consider positioner or booster.
B. Improper action; port "A" or "B" connections are reversed.	B. Reference Tables 1 and 2 herein for desired action and proper port; reverse as required.

3. Erratic operation; rapid cycling.

Possible Cause	Remedy
A. Insufficient PB.	A. Increase PB in 1/8 rev. increments by turning the needle valve CCW. Reset set point as required (Max PB at 1-1/2 revs.)
B. Improper air supply.	B1. Supply pressure too high. Reduce airset output supply pressure to 15-18 psig. B2. Air supply unsteady. Replace airset.
C. Pulsing process.	C1. Poor location of process temperature tap. Evaluate and consider relocation. C2. Steady process, if possible.
D. Non-correctable process dynamics.	D1. Bypass control valve positioner and directly load actuator. D2. Review sizing and characteristic of control valve, may be oversized. Use restricted trim, if necessary. D3. Consult factory.

4. Sluggish operation; slow action.

Possible Cause	Remedy
A. Restricted flow(s)	A1. Disconnect tubing and blow sensing line. A2. Check equivalent output tubing line length against those indicated herein in Section II.1.c. Relocate controller, or consider adding an air booster or positioner at the control valve. A3. Check for mashed or pinched tubing. A4. Installation debris. Air-blow lines. A5. Ice in lines. Use dry air supply.
B. Insufficient air supply.	B. Increase supply up to 18-20 psig.
C. Too much PB.	C. Decrease PB in 1/8 rev. increments. Reset set point as required.
D. Poor sensing location of thermal bulb.	D1. Delete thermal well, if possible. Pack void space between bulb and well with heat transfer medium. D2. Evaluate and consider relocation.
E. Too large actuator.	E. Add on air booster or positioner at the actuator.
F. Use of alcohols, glycols in freezing weather; dissolved lubricant on O-rings.	F. Remove sensor sub-assembly and lubricate O-rings.

5. Calibration erratic; frequent setpoint adjustments.

Possible Cause	Remedy
A. Sensing thermal bulb loose at screwed connection to housing.	A. Piping weight is cantilevered off of instrument air connections causing unscrewing, and effecting internal clearances. Change piping or add supports as required. Recalibrate.
B. Air supply debris.	B1. Provide a cleaner air supply or piping source. B2. Ice in lines. Correct as necessary.

6. Leakage of process fluid.

Possible Cause	Remedy
A. Thermal bulb and/or thermal well failure.	A1. Chemical attack. Consult factory. A2. Severe over-temperature. Replace unit.

7. Cannot reach upper or lower temperature levels of stated range.

Possible Cause	Remedy
A. Improper sensor sub-assembly setting.	A. Remove sensor sub-assembly. Check dimension to those indicated in Figure 9. If dimension is correct, and high setting cannot be reached, decrease dim "X" by rotating sensor end plate 1/2 revolution CW; reverse for lower setting.

SECTION VIII

VIII. PARTS ORDERING INFORMATION

There are three methods to obtain parts ordering information/numbers. These methods are listed below, in order of ease of entering. The least expensive method is to utilize parts in kits where possible.

METHOD A — USE OF PRODUCT CODE

Step 1. If available, obtain the 18 character product code number from:

- a. The Bill of Materials sheet attached herein.
- b. The metal tag attached to the valve.

□ □ □ - □ □ □ 7 - □ □ □ □ □ □ □ □ □ □

***NOTE:** Some controllers may not have the product code located on a metal nameplate.*

Step 2. Identify the kit or parts from the following:

- a. The Bill of Materials sheet attached herein and Table 3.
- b. Kit "A" contains replacement O-rings.

Step 3. Contact your local Cashco, Inc. Sales Representative and specify the product code number, the kit designation/number, and any part numbers not included in the desired kit. Costs of required parts and kit can be given by the Sales Representative.

METHOD B — NO PRODUCT CODE AVAILABLE — DISASSEMBLED CONTROLLER.

Step 1. Determine all available information from valve's metal tag.

- a. Serial number.
- b. Controller "Type" or "Model" number
- c. Temperature Range

Step 2. With the information from Step 1, contact your local Cashco, Inc. Sales Representative for the proper identification numbers to use and the parts cost.

METHOD C — NO PRODUCT CODE AVAILABLE — ASSEMBLED CONTROLLER IN SERVICE

Step 1. Determine all available information from valve tag using Step 1, Method B.

Step 2. Contact your local Cashco, Inc. Sales Representative with the above information.

Step 3. Sales Representative will contact the factory to determine the original internal construction. Factory will relay information to the Sales Representative.

Step 4. Await the Sales Representative's return contact with the proper part numbers and cost.

**TABLE 3
PART KIT NUMBER
MODEL 764T TEMPERATURE CONTROLLER
(Kit No. Shaded)**

Wetted Construction	Kit Abbreviation	Temperature Range
		ALL
Brass and 316SST	A	CB1-000K-0A

NOTE: High Temperature Thermal Bulb (Opt. -63) sectional drawing and item number callouts may be found on page 4, Figure 6.

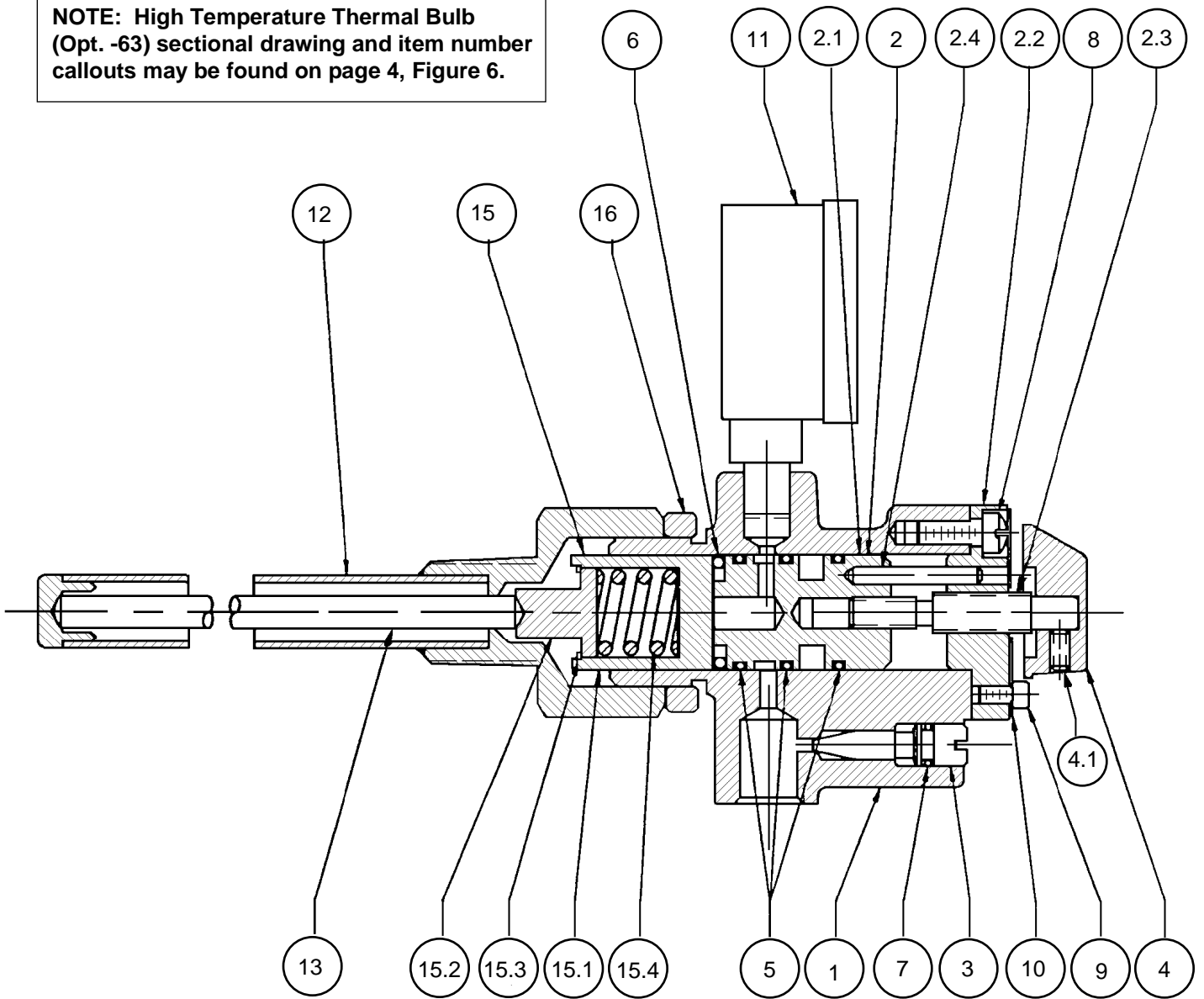

Figure 10

<u>Item No.</u>	<u>Description</u>	<u>Item No.</u>	<u>Description</u>
1	Housing	12	Thermal Bulb Assembly
2	Sensor Subassembly	13	Sensing Rod
2.1	Sensor	15	Sensor Plate Subassembly
2.2	End Plate	15.1	Sensor Plate
2.3	Adjusting Screw	15.2	Adaptor
2.4	Sensor Pin	15.3	Retaining Ring
3	Needle Valve	15.4	Spring
4	Knob	16	Lock Nut
4.1	Set Screw		
5	O-ring - Sensor		
6	O-ring - Sensor Plate		
7	O-ring - Needle Valve		
8	End Plate Screw		
9	Dial Screw		
10	Temperature Dial		
11	Gauge		
		Not Shown:	
		17	Thermal Well