



MODEL 9520R

I/P – ELECTRO-PNEUMATIC POSITIONER FOR ROTARY VALVES

SECTION I

I. DESCRIPTION AND SCOPE

Model 9520R is a single acting, compact, force-balance, electro-pneumatic (I/P) positioner used on rotary travel (rotary stem) control valves. This positioner is utilized to characterize the relationship between valve stem position and the system's control signal. This design is only suitable for nominal 4-20 mA input signals, or split range variations thereof.

The 9520R is CSA and FM approved as an intrinsically safe I/P positioner. (See Technical Bulletin 9520R-TB.)

Each unit comes complete with a set of gauges located on an external adapter/gauge block. A clear plastic lens covers the gauges to minimize damage and environmental effects. Gauges monitor air supply "IAS" and output "LOAD".

The Model 9520R I/P positioner may be utilized with the following current Cashco product models:

Ranger QCT
Premier EZO
Premier



**Model 9520R Mounted on a
Cashco Ranger QCT Control Valve**

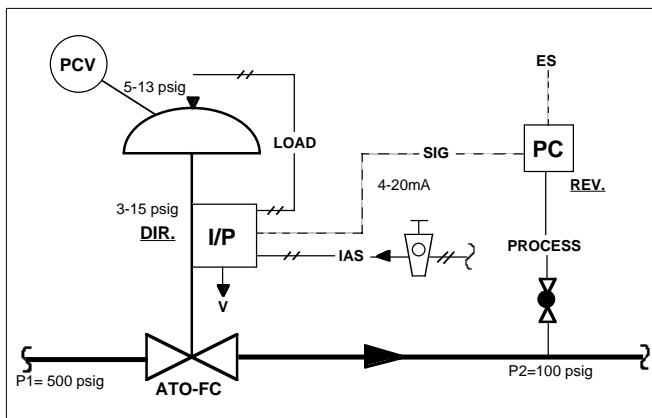

Figure 1: Typical Pressure Reducing Electronic/Pneumatic Control Loop - PCV with I/P Positioner

IAS - Instrument Air Supply
PC - Pressure Controller
PCV - Pressure Control Valve
ATO-FC - Air-to-Open, Fail Close
ATC-FO - Air-to-Close, Fail Open
I/P - Electric Current Input/Pneumatic Output
DIR - Direct Acting
REV - Reverse Acting
SIG - Controller Output Signal
V - Vent
ES - Electrical Supply
CW - Clockwise Rotation
CCW - Counter-Clockwise Rotation

SECTION II

II. METHOD OF OPERATION (See Figure 2)

The positioner operates with an electro-mechanical signal transducer and with the force balance principle: an electromagnetic coil internally converts the electronic input signal "SIG" (4-20mA) into a proportional pneumatic signal which acts on the input diaphragm (50). The stroke of the input diaphragm is transferred to the flapper lever (38). The resulting movement of the flapper varies the dynamic pressure at the nozzle (51). This pressure acts on the amplifier (53) and the change in output pressure causes a movement of the actuator/valve stem.

The rotary movement is back fed from the valve stem (55), through a characterization cam (24), to the feedback lever (13) of the positioner, and transferred to the stroke factor lever (19). The stroke factor lever (19) is connected to the flapper lever (38) by means of a range spring (41).

A force balance is created on the flapper lever (38) when the force generated by the input diaphragm (50) balances with the counter-force produced on the range spring (41). This ensures that the actuator/valve stem position is always characterized to the input signal.

Dynamic matching of the actuator (sensitivity, stability) is factory set by means of the throttle screw (42) and the damping throttles (44). The stroke range and zero are set by means of the stroke factor thumbscrew (40) and the zero thumbscrew (39). The changeover plate (15) is used to set either an increasing or decreasing output pressure for an increasing input signal, i.e. direct or reverse acting.

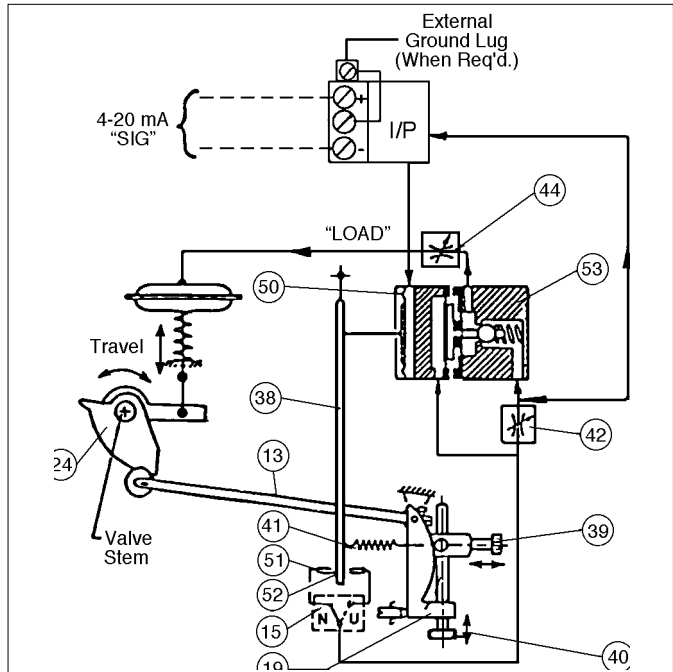

Figure 2: Single-acting I/P rotary positioner functional diagram.

SECTION III

III. MOUNTING TO SPRING DIAPHRAGM ACTUATORS

A. The following text applies to the field mounting of a positioner to a valve originally not supplied with a shaft-end positioner. (Refer to Appendix A if the valve has a Model 9000R P/P positioner installed.)

B. Mounting Kit:

1. A factory-supplied field mounting kit must be obtained. Request "Model 9520R I/P Field Installation Kit" (FIK) and indicate the following:
 - a. Unit's serial number
 - b. Product model; i.e. Ranger, Premier, or Premier EZO
 - c. Valve body size
 - d. Actuator bench range
 - e. Desired characteristic; i.e. =%, linear
 - f. ATO-FC or ATC-FO action.

2. An airset with gauge is required. Request separately from positioner FIK.
3. If a position indicating switch (by Bettis or Proximity Controls) is shaft-end-mounted, the use of the position switch(es) must be abandoned or replaced with probe-type Proximity switch(es) ("Go" Series 70) mounted on the yoke. **NOTE:** These units are available on 1"-4" Rangers and 3"-4" Premiers only.

C. Mounting Side:

When viewed from the valve stem end, with the actuator casing defined as upwards (above stem), the position indication portion should be to the "left", and the positioner section should be to the "right".

D. Existing Control Valve Modifications:

1. Refer to IOM #M93002 for instructions for the rotary actuators used on Ranger QCT, Premier EZO and Premier (unlined).
2. All indicated Item Numbers that are with respect to IOM #M93002 will be in parenthesis and underscored; i.e. (32). All part Item Numbers that are with respect to this IOM-9520R are not underscored; i.e. (32).

NOTE: *If no handwheel (58) or adjusting screw assembly is provided with the actuator, it is recommended that the rod end (9) be uncoupled from the arms (5) by removal of bolt (40). See IOM #M93002. Use of air loading into the actuator casing (1) is possible, but introduces safety considerations; i.e. use "tools" and not "fingers" inside the arm housing (4) area.*

3. Remove cover plate (20).

#48 Actuator: (See Figure 3)

- 4a. Turn actuator handwheel CW to remove stem windup torque. The linkage from the actuator stem (9) will become slack. May require 1-3 revolutions. This will ease removal of cap screws (31).
- 4b. Remove three cap screws (31), dial lens (14), travel indicator dial (15), cover plate (13), cap screw (32), travel indicator (16), lock washer (55) and pin (51).
- 4c. Discard removed dial lens (14), travel indicator dial (15), cover plate (13), cap screw (32), travel indicator (16), washer (55) and pin (51). Save only cap screws (31) for re-use.
- 4d. Install new drive coupling (32) into the stem (7) end. Use Loctite #242 removeable thread sealant, or equal, to assure that threaded connection will not loosen.
- 4e. Place new cover plate (13) over drive coupling (32). Position cover plate (13) so that the "notch" moisture drain is at the 11 o'clock position. Using handwheel and an awl, align tapped openings in arm housing (4), bearing retainers (19), and housing cover (13). Install all three cap screws (31) prior to tightening of any one cap screw to assure ease in alignment. Tighten cap screws (31).

#148 or #148X Actuators: (See Figure 3)

- 4a. Turn actuator handwheel (58) CW to remove stem windup torque. The linkage from the actuator stem (9) will become slack. May require 1-3 revolutions. This will ease removal of cover plate (13).
- 4b. Remove four cap screws (34), two cap screws (31), dial lens (14), travel indicator dial (15), cap screw (32), travel indicator (16), expansion pin (50), lock washer (55) and pin (51).
- 4c. Remove cover plate (13) carefully, prying out with a screwdriver or similar instrument. Shaft-end bearing (18) may slide out when cover plate (13) is removed; if so, remove bearing (18) and reposition over indicator spacer (17).
- 4d. Discard removed dial lens (14), travel indicator dial (15), coverplate (13), two cap screws (31), travel indicator (16), expansion pin (50), cap screw (32) and pin (51). Save only four cap screws (34) for re-use.
- 4e. Install new drive coupling (32) with washer (W) into the stem (7) end. Use Loctite #242 removeable thread sealant, or equal, to assure that threaded connection will not loosen.
- 4f. Place new cover plate (13) over drive coupling (32). Using handwheel, align female opening in arm housing (4) until the male portion of cover plate (13) can be inserted and pushed over the outer edge of bearing (18). When aligned, re-install four cap screws (34) assuring of even drawdown and flush mating of machined surfaces between arm housing (4) and cover plate (13).
- 4g. Rotate handwheel CCW until handwheel torque/tension is released.
5. Mount rotary positioner baseplate (26) to housing cover (13) using three cap screws (A1). Align baseplate (26) to be parallel with bottom of valve's arm housing (4). See III.C.
6. Determine characterization cam's (24) proper orientation as indicated in Figures 8 thru 15; cut a spacer from wood or heavy cardboard to the dimension "X" indicated.

NOTE: Whether air-to-open (ATO) or air-to-close (ATC), Cashco's Ranger QCT, Premier (unlined) or Premier EZO all rotate clockwise (CW) to "close" valve, or counter clockwise (CCW) to "open" valve, when viewed from stem (7) end.

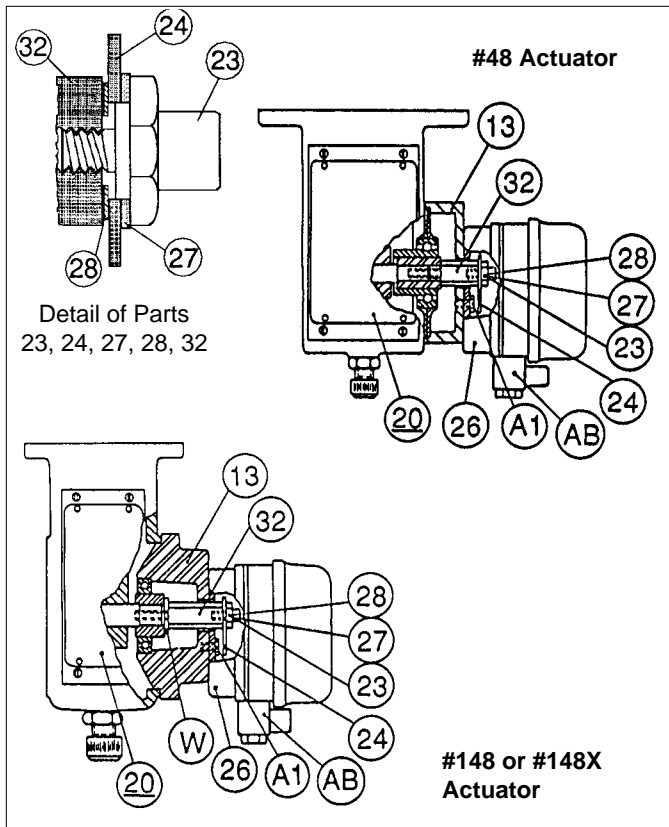

Figure 3

7. Place a thin film of adhesive, glue or pipe thread sealant on the "back" side of cam (24) to secure toothed lock washer (28) to cam (24). Use post end screw (23) to correctly align centers of these three parts (24, 27 & 28); do not allow the post-end screw (23) to adhere to these parts.
8. Using the spacer of step 6., position cam (24) with adhered parts (27 & 28) up to the end of drive coupling (32). Carefully screw-in post-end screw (23) while holding cam (24) in its approximate position. Hand-tighten post-end screw (23) until certain that the washers (27 & 28) have remained in alignment. (If washers (27 & 28) are misaligned, the cam (24) will not be able to be secured.)
9. Using the spacer of Step 6. above, wrench-tighten post-end screw (23) into a preliminary position.
10. As shown in Figure 4, attach the feedback lever (13) onto the positioner unit's main shaft (17) by hand-tightening socket cap screw (21). DO NOT WRENCH TIGHTEN SCREW (21).

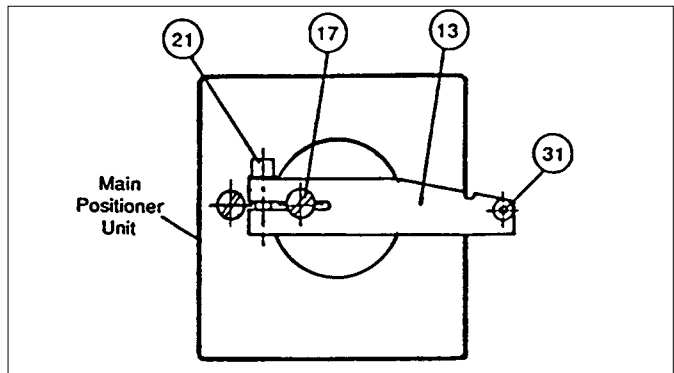

Figure 4 - Rear View

11. Remove the two plastic screws in the right-side of the main positioner unit where cap screws (11) would be inserted. (See Figure 5.)
12. Begin to set the main positioner unit near its final position on baseplate (26). Using needle nose pliers grasp compensating spring (18) and "hook" the end of the spring (18) under the lower side of the feedback lever (13) as indicated in Figure 5.

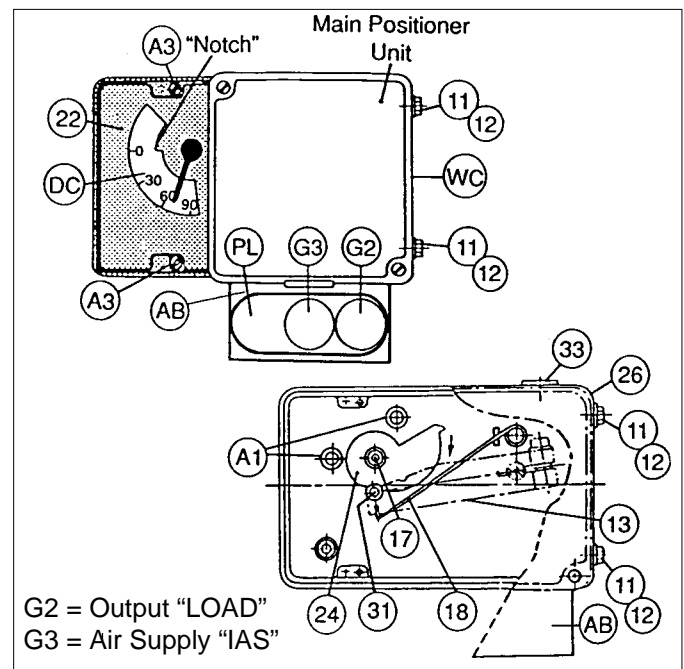

Figure 5

13. Position the positioner unit onto baseplate (26), assuring that the feedback lever's (13) roller is placed into contact with characterization cam (24) into the approximately proper location. (See Figures 8 thru 15.)
14. Fasten the positioner unit to the baseplate (26) inserting two cap screws (11) with lock washers (12) thru the side of baseplate (26).
15. Remove the positioner cover (WC). Remove plastic plug (33) from the upper edge of baseplate (26), allowing access to the socket cap screw (21).

16. Press the stroke factor lever (19) (See Figure 6) of the positioner's internals against the travel stop pin (20) and hold firmly in place. Using the #5 Allen wrench provided, securely tighten socket cap screw (21) to the main shaft (17) while holding the stroke factor lever (19). Replace plastic plug (33).
17. Install adapter/gauge block (AB) with four O-rings (OR) to main positioner unit, with the connections oriented to the rear, and the gauges (G2 & G3) facing the front. A clear plastic lens (PL) covers the gauges
18. Install tubing fittings with acceptable thread sealant and tubing from the unit's 1/4" NPT (female) "OUTPUT 1" port of the adapter/gauge block (AB) up to the connection port of the actuator casing. **NOTE - Thread Sealants:** *If TFE tape is used, make sure that small pieces of tape will not be "pinched off" and enter the pneumatic internals. (Liquid thread sealants are not recommended.)*
19. Place temporary fittings and tubing so that the positioner is able to be supplied with a 20-44 psig air supply to the "SUPPLY AIR" port of the adapter/gauge block (AB). Supply pressure depends upon actuator bench setting; see Table 1.

Table 1

Actuator Bench Setting (psig)	Supply Pressure, psig	
	Recommend	Maximum
5-13	20	25
7.5-19.5	27	30
10-26	36	40
14-30	44	45

20. (See Section VII, Figure 21 and Figure 22.) Remove the terminal block cover (TBC), exposing the terminal connections +, -, and Ground. Connect an electric signal generator power supply to the proper terminal to provide a 4-20 mA current supply. Polarity may vary from signal generator to signal generator; however, polarity is normally as indicated in Figure 20.
21. For units with a 4-20 mA span, vary the signal generator output thru the 4-20 mA span. This should stroke the valve through its full travel. Observe the feedback linkage to assure that the linkage does not bind and does not experience overtravel. At a 12 mA signal input, the feedback lever should be approximately horizontal. (For split range signals the midpoint value would be halfway between the lower and upper values; i.e. 4-12 mA span, midpoint at 8

mA.) **NOTE:** *If no response comes from the positioner/valve when the "SIG" is varied from 4-20 mA, reverse the polarity of the wiring and re-attempt.*

IMPORTANT NOTE: *If the feedback lever (13) is turned forcibly against the travel stop pin (20), the stroke factor lever (19) will be released from rigid connection (unscrews) to the positioner main shaft (17). If this occurs, the positioner unit must be removed from the rotary baseplate (26). Using a screwdriver, hand tighten the main shaft (17) by turning CW (as viewed from main shaft (17) end) as tightly as able while holding the stroke factor lever (19) firmly against the travel stop pin (20).*

22. Place decal (DC) onto indicator cover (22) backside as indicated in Figure 5. Trim the decal to remove the "120°" indication. Align the "0°" position to the notch of the indicator cover (22); the "0°", "30°", "60°" and "90°" tick-marks should touch the outside arc of the clear portion of indicator cover (22).
23. Check the valve's actual position of the plug. Place plastic red pointer (34) just barely onto post-end screw (23). Calibrate pointer (34) to indicator cover (22) by repositioning pointer (34) as required. When calibration is satisfactory, press pointer (34) firmly down over post-end screw (23).
24. Fasten clear indicator cover (22) into place using two cap screws (A3).
25. Leave temporary air source and signal generator as installed for final calibration, Section V, but turn off the air supply and current supply so that no pressure or electrical source are induced to the internals.

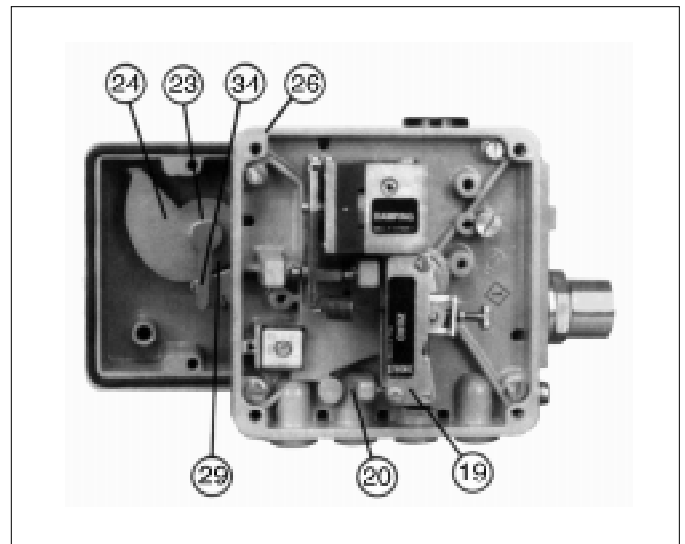

Figure 6

SECTION IV

IV. BASIC ADJUSTMENTS / SETTINGS

B. Action Setting:

A. Required Tools:

The following tools are required for the basic adjustment:





1. Screwdriver
2. Open-end wrench - 6 mm
3. Feeler gauge 0.6 mm (.024 in)
4. (2) test gauges-30 psig (for 20 psig max bench range); (1) test gauge -30 psig and (1) test gauge -60 psig (for 30 psig max bench range)
5. Manual loader/airset
6. Open-end wrench - 10mm
7. Needle-nose pliers; small
8. #5 Allen wrench (5mm provided)
9. Current (4-20 mA) signal generator

1. Refer to Table 2 to see the graphical indicated position of the changeover plate (15). The indicator arrow is located on the edge of the baseplate (BP). There are two positions for this pneumatic switch to be in:

“N” - Direct action
“U” - Reverse action



2. The “N” and “U” are labels cast into the surface of the changeover plate (15). If necessary, to change action loosen CP screw (4) to removal. Lift the changeover plate (15) and its CP gasket and replace them to align the label with the arrow as desired. Replace and re-tighten changeover plate screw (4).

TABLE 2

Control Valve Action/Fail Position	Positioner		Stem Travel Direction	Plug Action With Signal Increasing
	Action	Changeover Plate Setting		
ATO-FC	Direct		CW to Close CCW to Open	Opens
ATC-FO	Direct		CW to Close CCW to Open	Closes
ATC-FO	Reverse		CW to Close CCW to Open	Opens
ATO-FC	Reverse		CW to Close CCW to Open	Closes

**TABLE 3
RANGE SPRING SELECTION**

Input “SIG” psig	Product & Cam Character	P/N *	Color Code	Product & Cam Character	P/N *	Color Code
4-20	Ranger - = %	-08000-	Light Yellow	Ranger - Linear or Premier - = %	-08001-	Olive Green
4-12		-08000-	Light Yellow		-08001-	Olive Green
12-20		-08000-	Light Yellow		-08001-	Olive Green
4-9.3		-08001-	Olive Green		-08002-	Light Gray
9.3-14.7		-08001-	Olive Green		-08002-	Light Gray
14.7-20		-08001-	Olive Green		-08002-	Light Gray

PART NO.	COLOR CODE	NO. COILS
 830-69-5-08002-00	Light Gray	7-1/4
 830-69-5-08001-00	Olive Green	6-3/4
 830-69-5-08000-00	Light Yellow	5-3/4

* Complete Cashco part number (P/N) is as shown in Figure 7. Table 3 indicates the missing numbers of the complete P/N; general P/N = 830-69-5-_____-00.

Figure 7

**CHARACTERIZATION CAM SELECTION & ORIENTATION
VS. CONTROL VALVE ACTION –
RANGER & PREMIER PRODUCTS**

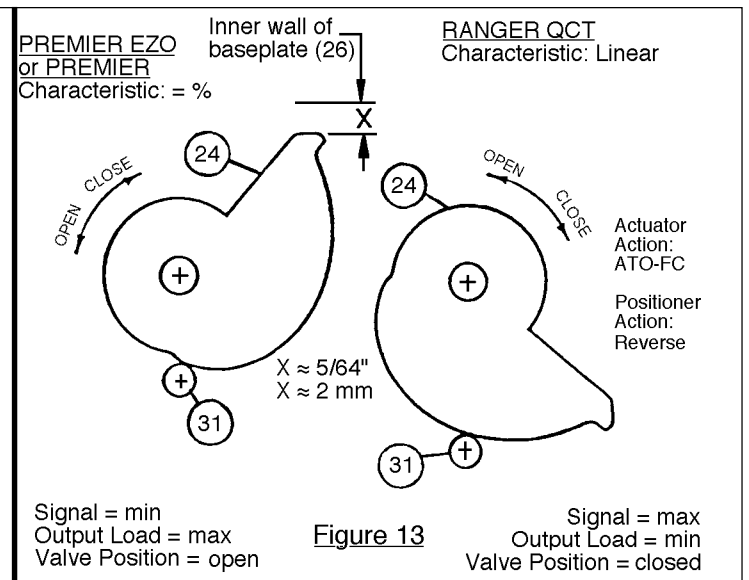
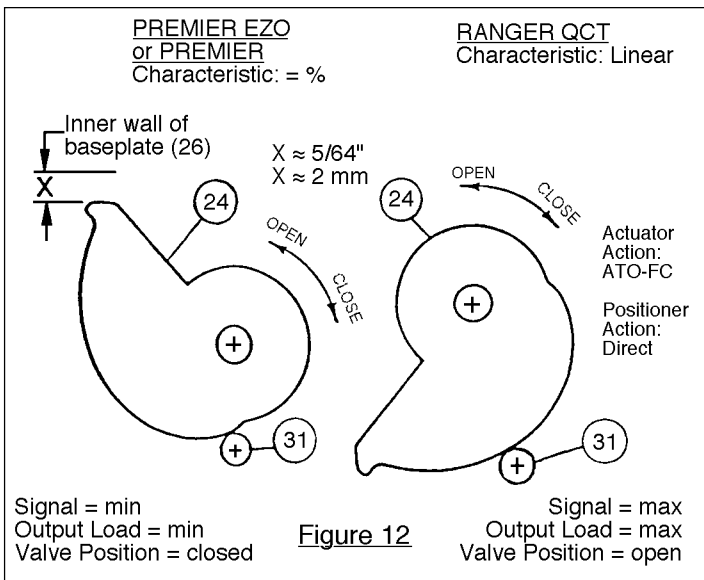
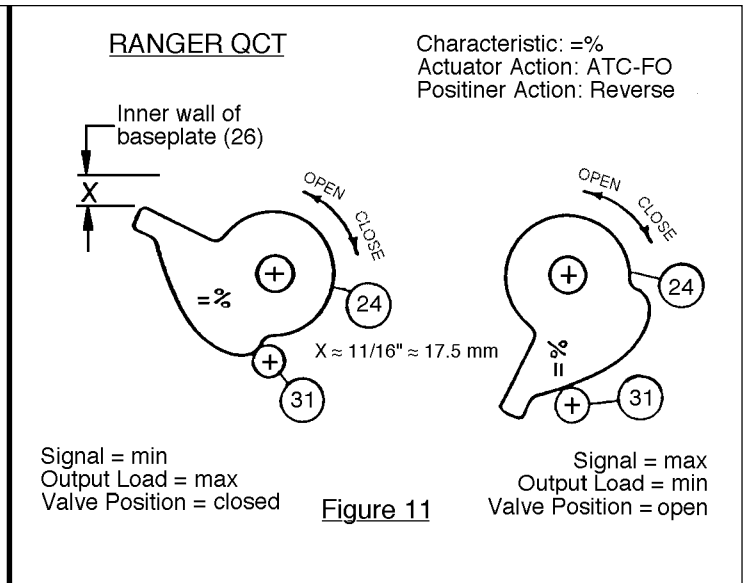
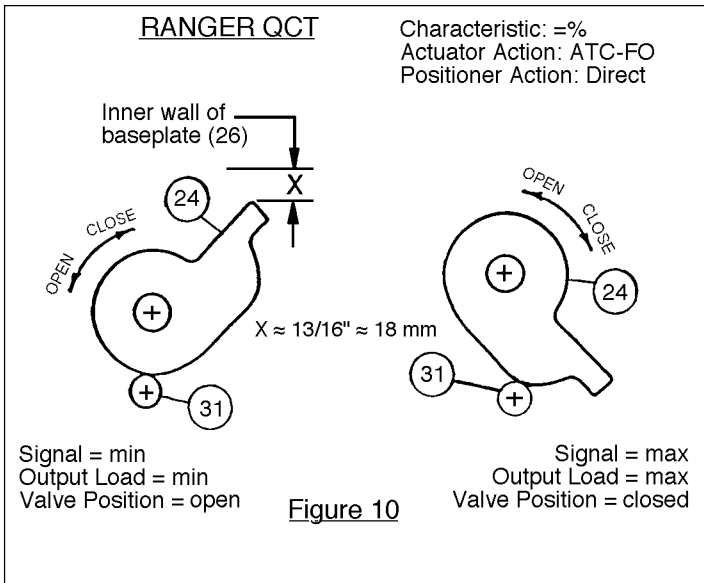
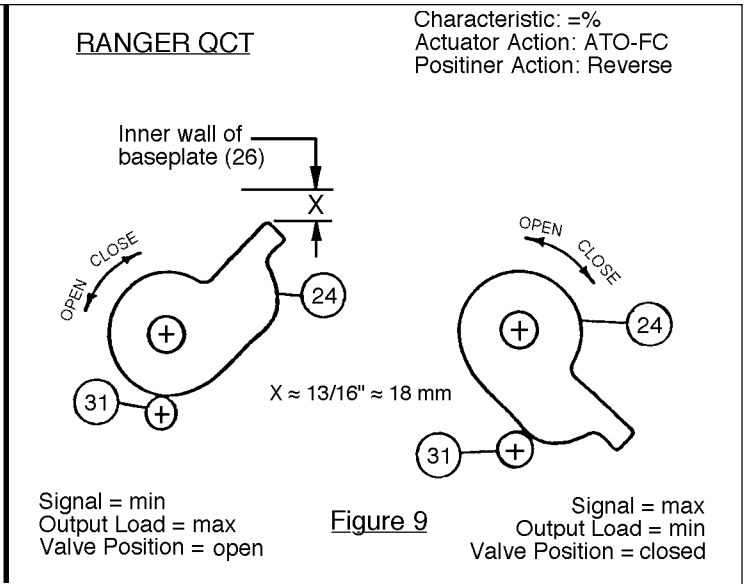
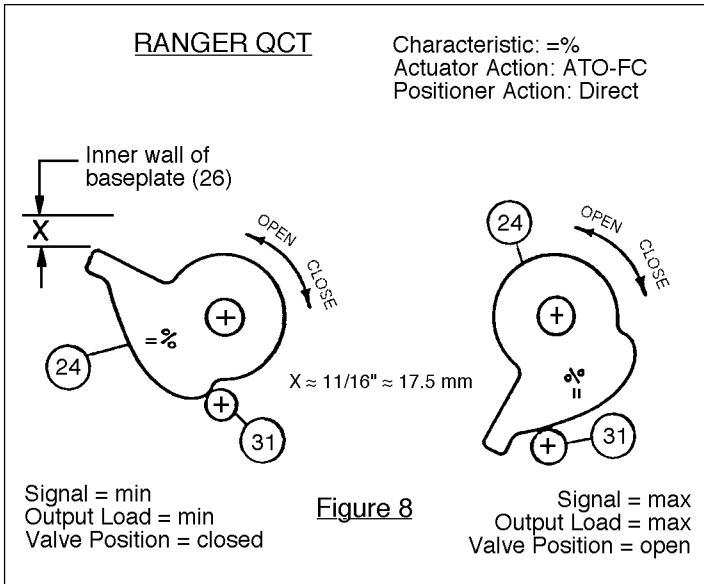

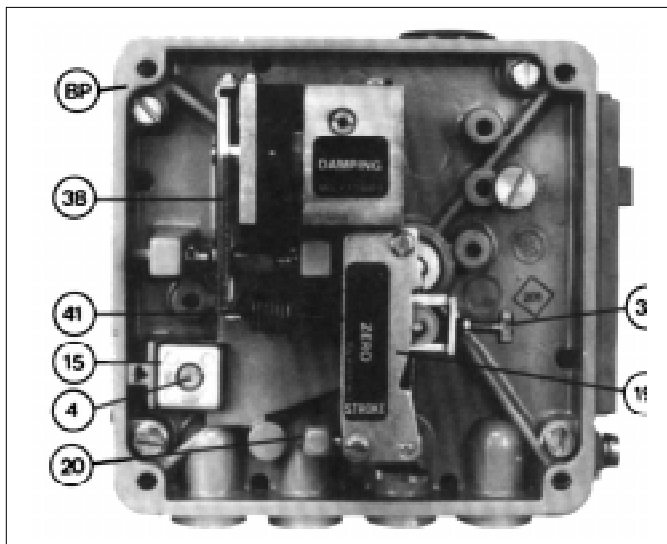
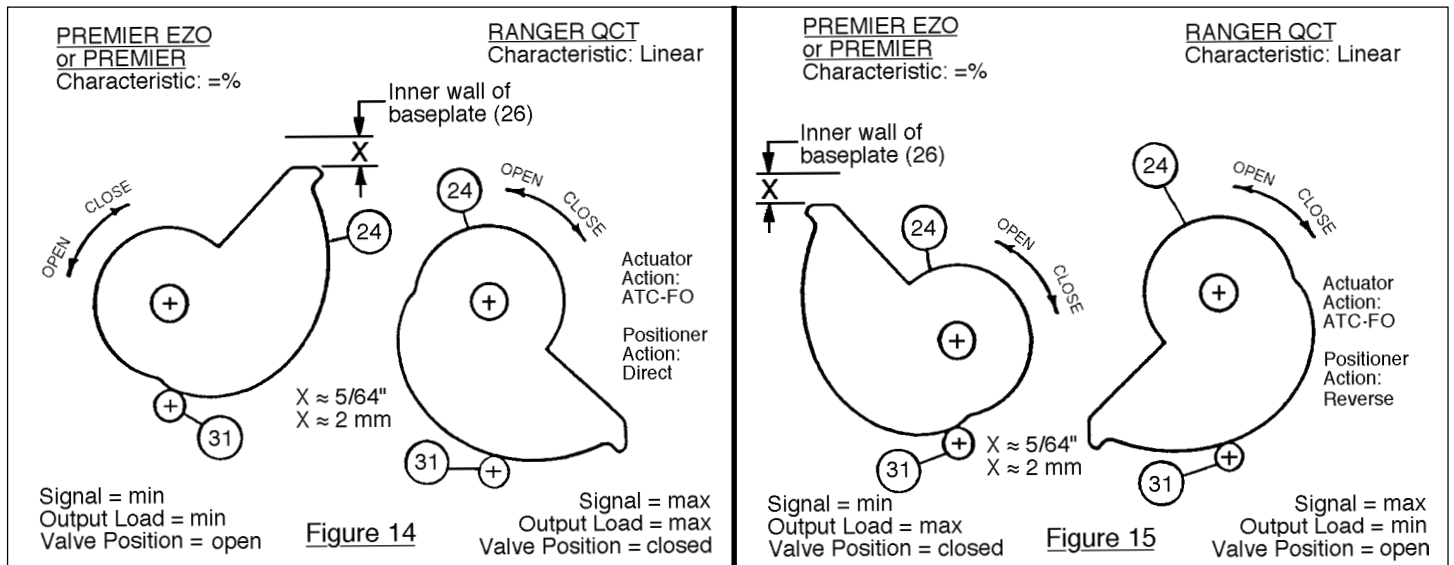

Figure 16

C. Range Spring Selection:

1. Each positioner unit is supplied with a color-coded range spring(41). Figure 7 shows the springs; identification is also by the number of coils. The range spring (41) to be utilized is indicated in Table 3.
2. To remove/change the range spring (41), hold stroke factor lever (19) against the travel stop pin (20) and simultaneously hold the zero thumbscrew (39). Using needle nose pliers, remove the end of the range spring (41) hooked to the flapper lever (38); then remove from the zero mechanism. Reverse the procedure with the new/different range spring (41). Always make sure that the range spring's (41) coils are closest to the flapper lever (38).
3. After removal/change of the range spring (41), recalibration is required. See Section V.

SECTION V

V. CALIBRATION / ADJUSTMENTS

A. ZERO and STROKE Setting: (See Figure 17)

1. Re-introduce the instrument air supply "IAS" and electronic current signal generator "SIG" set up in Section III previous.
2. Recheck character cam (24) position carefully. Loosen post-end screw (23) and retighten as required to maintain dimension "X" spacing per Figures 8 thru 15. Valve may need to be stroked to "full open" or "full closed" position to allow measurement of "X". (**NOTE: Do not locate cam follower (31) in "valley" of the equal % or linear cams (24) at either end of stroke; follower (31) will always be slightly out of the "valley".**) Stroke valve thru full travel to assure proper cam (24) orientation.
3. If the valve is to start travel with a signal of *less than 9.33 mA*, go to Step 5. If the valve is to start travel with a 9.33 mA or *greater* signal, proceed to Step 4.

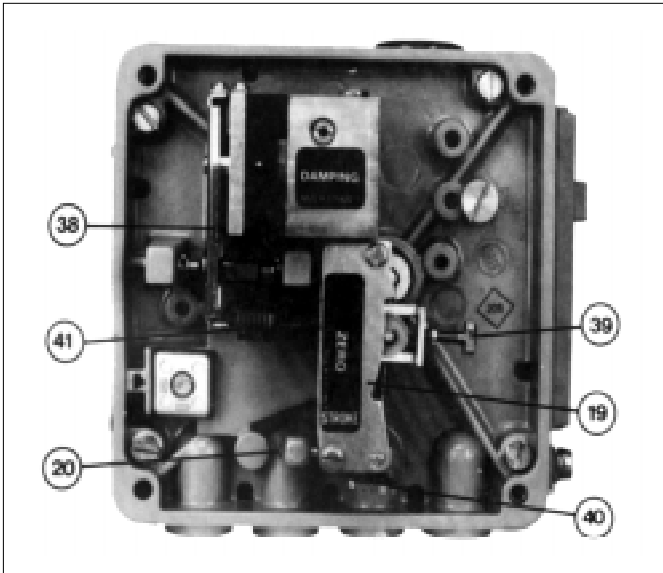

Figure 17

4. If the positioner is split ranged for 9.33-14.67, 14.67-20, or 12-20 mA "SIG" input (i.e. zero stroke is at a 9.33 mA, 14.67 mA or 12 mA "SIG" respectively for DIRECT action; full stroke is at a 9.33 mA, 14.67 mA, or 12 mA "SIG" respectively for REVERSE action), then follow this procedure:

- a. Shutoff supply air ("IAS", i.e. 0 psig).
- b. Release all tension on range spring (41) by turning zero thumbscrew (39) CCW.
- c. See Figure 4; loosen screw (21) securing the feedback lever (13) on the backside of the unit to the main shaft (17) using a #5 Allen wrench. Manually move the stroke factor lever (19) away from the tip of the stop pin (20) a distance of approximately 1/4"-3/8" using some form of spacer; i.e. folded cardboard, etc. Retighten feedback lever (13) to main shaft (17). Remove the temporary 1/4"- 3/8" spacer.
- d. Introduce an air supply ("IAS") to the positioner as required by Table 2.
- e. Press the flapper lever (38) several times to the left and right until the flappers are correctly aligned.
- f. Set the minimum input "SIG" with the signal generator; i.e. 12 mA for 12-20 mA span, 9.33 mA for 9.33-14.67 mA span, or 14.67 mA for 14.67-20 mA span.
- g. Turn zero thumbscrew (39) CW, increasing tension of range spring (41), until the

actuator begins to move away from its zero (shelf) position. (If adjustment does not cause valve response, turn off air supply ("IAS") and return to 4.c. left; increase the temporary spacer thickness in increments of 1/8" and repeat steps until the valve does move). Care should be taken to assure that the stroke factor lever (19) does not overtravel from the starting point to the point where the stroke factor lever (19) will hit the housing cover (WC), before reaching its end position - approximately 39° rotation.

- h. Induce the maximum input "SIG" with the signal generator; i.e. 20 mA for 12-20 mA span, 14.67 mA for 9.33-14.67 mA span, or 20 mA for a 14.67-20 mA span.
 - i. Turn the stroke factor thumbscrew (40) CW; this shortens the valve stroke with respect to the "SIG" change; i.e. less air pressure required to reach valve's maximum stroke position. Once valve stem moves with each CW adjustment of the stroke factor thumbscrew (40), reverse to CCW rotation of stroke factor thumbscrew (40) and precisely adjust up to the maximum stroke position of the control valve.
 - j. Repeat Steps e. and h. a minimum of three times, as under this adjustment of Steps b. and c. above, the STROKE and ZERO adjustments are mutually dependent; i.e. interacting.
 - k. If procedures of Step 4 above have been completed, skip Step 5 following, and go to next paragraph V.B.
5. Press the flapper lever (38) several times to the left and right until the flappers are correctly aligned.
- a. Induce the minimum value of the input signal ("SIG") using the electronic signal generator. (This corresponds to the start of the valve's stroke.)
 - b. Turn the zero thumbscrew (39) either CW or CCW until the actuator begins to cause valve stem travel. Precisely adjust to the point where travel just begins.
 - c. Induce the maximum value of the input "SIG". (This corresponds to the end of the valve's stroke.)

- d. Turn the stroke factor thumbscrew (40) first CCW until observing the shortening of the valve's stroke. Turn the stroke factor thumbscrew (40) CW until the valve travel is precisely at its full stroke.
- e. Recheck the ZERO and STROKE settings. They should be repeatable. Under this procedure for adjustment, the ZERO and STROKE calibrations are mutually independent (i.e. non-interacting, when the feedback lever (13) and travel stop pin (20) are properly installed and positioned).

B. Setting GAIN: (See Figure 18)

1. Increasing GAIN increases the sensitivity of the positioner to a change in the input "SIG". GAIN is normally factory set when mounted by the factory, and should not require field adjustment.
2. The open loop gain varies with the supply "IAS" pressure, and the values represent linear amplification. Table 4 is a guide to the gain available for each range spring (41) utilized:

TABLE 4

Supply Pressure (psig)	Adjustable Range
20	150:1
27	140:1
36	124:1
44	113:1

3. A change in GAIN is normally indicated when instability/sluggishness shows up at steady state operating conditions. If the positioner output "LOAD" seems to rapidly oscillate (psst-psst-psst-....) too much gain is present and GAIN setting should be reduced until stability is reached. If the positioner output "LOAD" does not react to small changes in the "SIG", insufficient GAIN may be present; increase GAIN until instability (psst-psst-psst-....) is present, then reduce as described previously. This procedure allows the gain of the control loop to match the dynamic requirements of the control system.
4. Determine whether GAIN should increase or decrease based on above text. To increase GAIN, rotate throttle screw (42) CW; to decrease GAIN, rotate the throttle screw (42)

CCW. To prevent overadjustment the throttle screw (42) is located within the limiting screw (43). This allows the throttle screw (42) to only be adjustable a total of approximately one revolution from maximum to minimum. Thus, GAIN should be adjusted slowly in very small increments.

5. If GAIN is adjusted, ZERO resetting may be required. Check and use Procedure V.A.



Figure 18

C. Setting DAMPING: (See Figure 18)

1. Increasing DAMPING introduces extra time constant to the output "LOAD" of the positioner. DAMPING should be increased/decreased depending on the time observed for the positioner to respond to a large change in input "SIG" during a non-steady state operating condition.
2. DAMPING is factory set, and normally requires minimal/no adjustment. However, if determined as required, DAMPING is adjustable from a minimum - to - maximum ratio of 1: 2.5. In its normal factory set position, the damping screw (44) is set approximately flush with the amplifier housing (53); this position is minimum DAMPING. As the damping screw (44) is screwed CW -inwards, DAMPING increases. DAMPING may be increased by up to approximately three full revolutions of the damping screw (44), which will represent maximum DAMPING.

SECTION VI

VI. MAINTENANCE

A. Adjustment of the Positioner: (See Figure 19)

1. Component adjustment is only required when the positioner has been disassembled or subassemblies have been exchanged. All settings performed in order to match the positioner to the actuator are described in Sections IV. and V.
2. See Section IV.A. for a list of required tools.

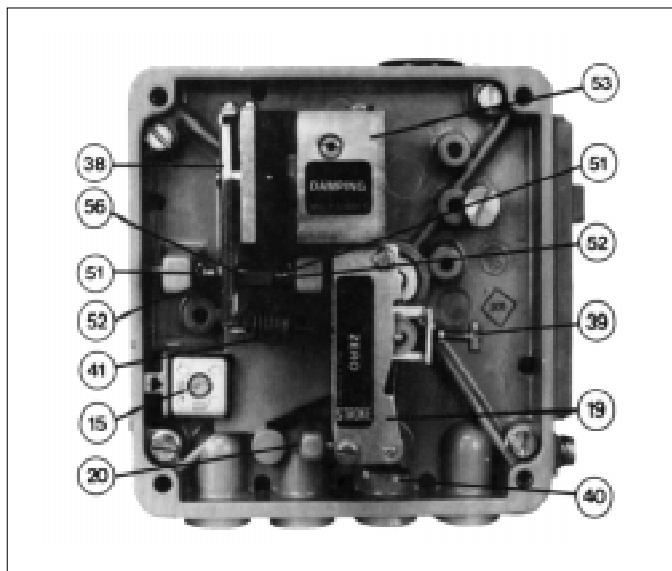

Figure 19

3. If adjustments are made with the positioner mounted on the control valve, the feedback lever (13) on the main shaft (17) of the positioner must be loosened. (See Section III:8-9.)
 - a. Set the changeover plate (15) to "N".
 - b. Turn the throttling screw (42) CW to its stops (maximum GAIN).
 - c. Unhook the range spring (41) from the flapper lever (38).
 - d. Check that the flappers (52) are aligned concentrically with the nozzles (51). (If necessary, loosen the AMPLIFIER mounting screws on the rear of the positioner and align the amplifier (53) sub-assembly accordingly.)
 - e. Press the flapper lever (38) several times alternately to the left and right, so that the ball-and-socket mounted flappers (52) are aligned parallel to the nozzles (51).

- f. Press the flapper lever (38) to the left. Set the clearance between the nozzle (51) and the flapper (52) to 0.6 mm (0.024 in.) with the aid of a feeler gauge by turning the hexagonal adjustor (56) with a 6 mm wrench. Then secure the nut against further turning using sealing paint.
- g. Connect the positioner as shown in the test circuit in Figure 20. Provide an "IAS" per Table 1.

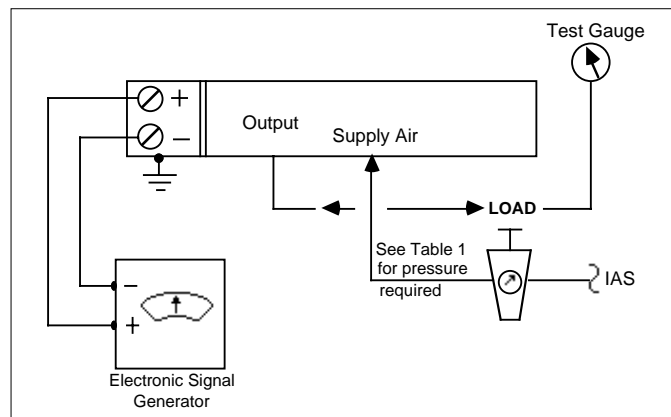

Figure 20

- h. Press the flapper lever (38) to the left. If the output does not rise to the level of the supply air pressure, either leaks are present or the flapper (52) is not correctly aligned (repeat e.).
 - i. Hook the range spring (41) onto the flapper lever (38), and provide a mid-range input "SIG" (12mA for 4-20mA, etc.).
4. The following procedure must be observed in order to achieve a no-feedback adjustment of the zero and stroke settings:
 - a. Press the stroke factor lever (19) against the travel stop pin (20).
 - b. Set the stroke factor thumbscrew (40) to a high stroke factor (approx. 5/64" before the upper stop).
 - c. Turn the zero thumbscrew (39) until the output pressure is mid-range of bench range (i.e. 6-30 psig bench setting, output \approx 18 psig) and make a note of this value.
 - d. Set the stroke factor thumbscrew (40) to a low stroke factor (approx. 5/64" before the lower stop). The output pressure may not vary by more than \pm 0.003 psig as compared with the setting described in c. above.

- e. In case of excessive deviations the travel stop pin (20) should be adjusted. Whenever the travel stop pin (20) is adjusted, the settings described in b. to d. should be repeated until the deviation is less than ± 0.003 psig.
 - f. Seal the travel stop pin (20) with sealing paint.
5. For mounting see Section III.
 6. Return the changeover plate (15) to its original position if it was "U". Re-tighten the feedback (13) lever onto the main shaft (17) of the positioner (See Section III.B.8 & 9.).

B. Cleaning The Throttle Screw: (See Figure 18)

1. Unscrew CCW the limiting screw (43). If you can't pull it out by hand, unscrew CCW the throttle screw (42) and remove both by hand.
2. Pull the throttle screw (42) out of the limiting screw (43).
3. Place the throttle screw (42) in a solvent (e.g. benzene) and blow through it carefully. It is best to clean in an ultrasonic solvent bath.
4. Turn the throttle screw (42) in again as far as it goes CW.

5. Turn the limiting screw (43) in as far as it goes CW; then back it out CCW by about half a revolution.
6. Secure the limiting screw (43) with sealing paint.

C. Replacing the Amplifier: (See Figure 19)

1. Unhook the range spring (41) from the flapper lever (38).
2. Unscrew and remove the amplifier (53) sub-assembly; the two amplifier mounting screws are accessible from the rear of the positioner.
3. Install a new amplifier (53). Do not forget the o-rings between the amplifier and the main unit's base-plate (BP) (air baffle). Before tightening, carefully align the mounting screws, position the amplifier (53) in such a way that the flappers (52) are concentrically aligned with the nozzles (51). **NOTE:** *It is recommended that the mounting screw be sealed from the back with a silicone sealant.*
4. Hook the range spring (41) onto the flapper lever (38).
5. Perform a maintenance basic adjustment and recalibrate per Section IV, V and VI.

SECTION VII.

VII. FIELD ELECTRICAL CONNECTIONS

(See Figures 21 and 22)

- A.** All field wiring and conduit must meet requirements of any/all locally prescribed codes (i.e. ANSI/ISA RP12.6). Such installation is the owner's responsibility.
- B.** Connecting rigid conduit is not recommended directly to the positioner; a 12"-18" length of flexible conduit is recommended. Conduit connection 1/2" size, female.
- C.** Interconnecting wiring should be 2-wire 16-22 AWG wire size, insulated and shielded as re-

quired. A fuse should be provided in the completed circuit. (No fuse is supplied with the positioner.)

- D.** Remove terminal block coverplate (TB) to gain access to the terminal connections +, - (38) and Internal Ground (36).
- E.** An external casing ground connection (37) is supplied, and may be used as an external ground if required by appropriate codes.
- F.** Instrument signal wiring is recommended to not be installed within conduit carrying power wiring. Shielded cable will help prevent stray induced currents from being imposed.

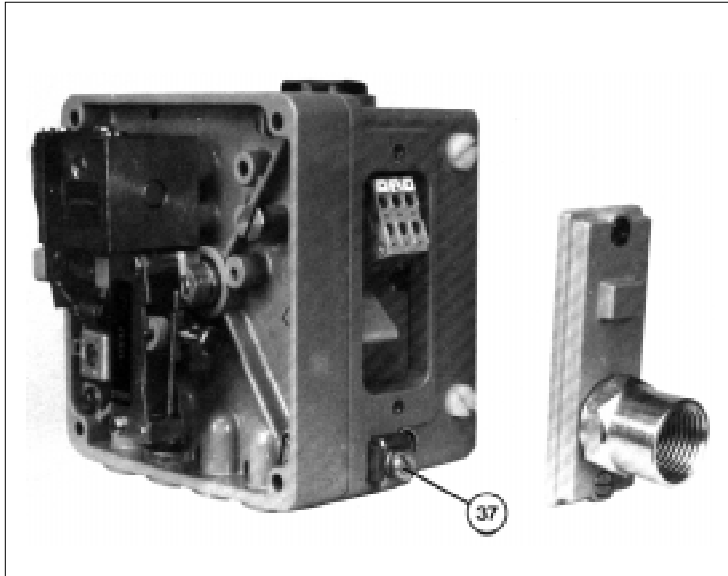

Figure 21

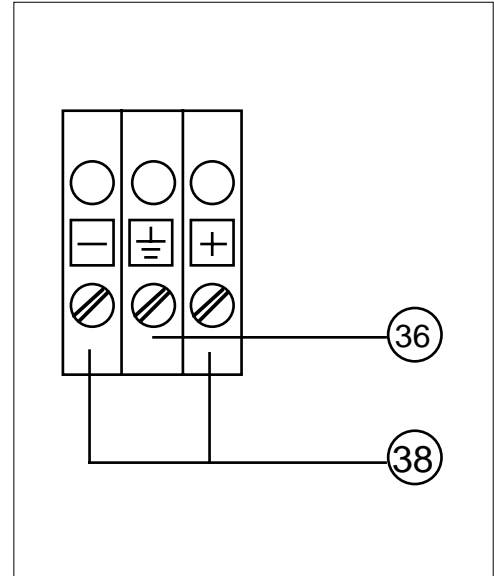

Figure 22

SECTION VIII.

VIII. TROUBLE SHOOTING GUIDE

1. Actuator does not respond to applied input signal.

Possible Causes	Remedies
A. Amplifier defective	A1. Replace positioner unit.
B. Pneumatic connections reversed	B1. Check connections.
C. Feedback lever not tightened	C1. Screw feedback lever tight (See III.B.9.)
D. Stroke factor lever is loose on the shaft	D1. Tighten shaft
E. Positioner mounted on the wrong side	E1. Check mounting side in accordance with table in Section III.
F. Changeover plate in the wrong orientation	F1. Check setting in accordance with table in Section III.
G. I/P transducer defective	G1. Replace positioner unit.

2. Output pressure does not reach its maximum.

Possible Causes	Remedies
A. Amplifier throttle dirty	A1. Remove and clean throttle (See VI.B.).
B. Supply air too low	B1. Check supply air pressure.
C. Flappers not parallel with nozzles	C1. Align flappers (See VI.A.d. - f.).
D. Supply air filter dirty	D1. Replace filter.

3. Actuator moves to end position.

Possible Causes	Remedies
A. Feedback lever not tightened	A1. Tighten feedback lever
B. Stroke factor lever loose on shaft	B1. Tighten shaft (See III.B.)

4. Unstable behavior; non-steady state in control loop.

Possible Causes	Remedies
A. Amplification too high	A1. Reduce amplification
B. Gland friction on the valve too high	B1. Loosen gland packing somewhat or replace

5. Stroke range cannot be adjusted.

Possible Causes	Remedies
A. Wrong range spring	A1. Replace range spring (See IV.D.)
B. Positioner does not completely reduce pressure	B1. Check supply air pressure. B2. Check amplification. B3. Adjust clearance between nozzle and flapper.

NOTE: Field repair to the electronics portion of the unit is **NOT RECOMMENDED**. Return to factory for repair or completely replace the unit.

REPAIR PARTS KITS

Kit A: Includes gaskets, O-rings and small parts.
Order P/N **295-08-5-07400-00**

Kit B: Replacement pneumatic amplifier
Order P/N **653-75-5-09542-00**

APPENDIX A

Removal of Model 9000R P/P Positioner

1. Reference Section III.D. Existing Control Valve Modifications, paragraphs 1. and 2.
2. Remove positioner unit (101) by removing four socket cap screws (33).
3. Remove range spring (102).
4. Remove both machine screws (37).
5. Remove feedback pivot link shaft (108), both spacers (109), and feedback linkage assembly (106, 107, 110, 111 and 112).
6. Install new cover plate (22), re-using socket cap screws (33).
7. Re-install both machine screws (37).
8. Discard unused parts at user's discretion.

NOTES

Cashco, Inc
P.O. Box 6
Ellsworth, KS 67439-0006
PH (785) 472-4461
Fax (785) 472-3539
E-mail: sales@cashco.com
 exportsales@cashco.com
Printed in U.S.A. IOM-9520R

-gh

IOM-MODELS

“9520R” & “9540R”-ADDENDUM

Applies to the following IOM: IOM-9520R, 10-93, Model 9520R, I/P - Electro-pneumatic Positioner & IOM-9540R, 8-89, MODEL 9540R, P/P - Pneumatic Positioner for Rotary Valves.

Subject of Addendum: Change in mounting and stem interconnection between valve end-of-shaft and positioner unit. Changes bring positioner into compliance with NAMUR Standard VDI/VDE #3845.

Replaces: Nothing previously issued; new issuance.

Reference: Section III, Sub-Section D, Article 4., page 3.

Replace the entirety of Article 4, for both the #48 Actuator and the #148 or 148X Actuators with the text below:

#48 Actuator: (See Figure 3)

- 4a. Turn actuator handwheel CW to remove stem windup torque. The linkage from the actuator stem (9) will become slack. May require 1-3 revolutions. This will ease removal of cap screws (31).
- 4b. Remove three cap screws (31), dial lens (14), travel indicator dial (15), cover plate (13), cap screw (32), travel indicator (16), lock washer (55) and pin (51). Remove bearing (18), both bearing flanges (19) and indicator spacer (17).
- 4c. Discard removed dial lens (14), travel indicator dial (15), cap screw (32), travel indicator (16), washer (55), pin (51) and indicator spacer (17). Save only cover plate (13), bearing (18) and both bearing flanges (19) for re-use.
- 4d. Position the new positioner spacer (17) over the valve stem (7 - Ranger, 3.2 - Premier) end, oriented as shown below in Figure 2.5.
- 4e. Put Loctite #242 thread locking sealant, or equal, onto the set screw (77). Engage the set screw (77) into the tapped end of the spacer (17), until the set screw (77) is projecting out of the spacer (17) 3/16" – 1/4" (5 – 6 mm).
- 4f. Position positioner baseplate (26) to positioner mounting bracket (76) properly oriented such that positioner baseplate (26) bottom edge is parallel to the bottom edge actuator arm housing (4). Opposite side boltholes of bracket (76) must also align with boltholes of actuator arm housing (4) and cover plate (13). Use four cap screws (79) to secure the baseplate (26) to the bracket (76). Place connected parts (26, 76, 79) aside.
- 4g. Position bearing flanges (19) with retainer ball bearing (18) over the spacer (17). Align the bearing flange (19) bolt holes with the arm housing (4) bolt holes.
- 4h. Position cover plate (13) over the bearing flanges (19) aligning the cover plate (13) bolt holes with those of the bearing flanges (19). Hold cover plate (13) on outer edge with fingers. **NOTE:** Ensure that the three tapped holes in the cover plate (13) used to mount the bracket (76) are near the 1 o'clock, 5 o'clock and 9 o'clock positions. Engage three cap screws (31) to secure spacer (17), bearing flanges (19) and cover plate (13) securely to arm housing (4). **NOTE:** It may be necessary to rotate the actuator manual handwheel operator (58) downwards, or alternately supply a small level of air pressure (5-7 psig, 0.35 - 0.50 Barg) to assist in aligning bolt holes for cap

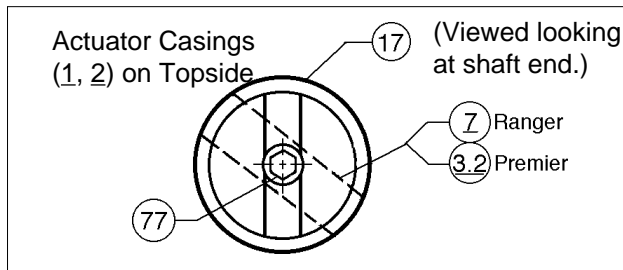

Figure 2.5 - Spacer Orientation

screws (31). Do not tighten one cap screw (31) until all three cap screws are partially thread-engaged.

- 4i. Position connected parts (26, 76, 79) of Step 4f., above, with the bracket (76) up and pressing against the cover plate (13), engaging the tongue-and-groove joint between the positioner baseplate rotary shaft (32) and the spacer (17) with its protruding set screw (77). Engage new cap screws (78) to secure the bracket (76) to the cover plate (13).

#148 or #148X Actuators: (See Figure 3)

- 4a. Turn actuator handwheel (58) CW to remove stem windup torque. The linkage from the actuator stem (9) will become slack. May require 1-3 revolutions. This will ease removal of cover plate (13).
- 4b. Remove four cap screws (34), two cap screws (31), dial lens (14), travel indicator dial (15), cap screw (32), travel indicator (16), lock washer (55) and pin (51).
- 4c. Remove cover plate (13) carefully, prying out with a screwdriver or similar instrument. Shaft-end bearing (18) may slide out when cover plate (13) is removed; otherwise, remove bearing (18).
- 4d. Remove indicator spacer (17).
- 4e. Discard removed dial lens (14), travel indicator dial (15), coverplate (13), two cap screws (31), travel indicator (16), cap screw (32), indicator spacer (17), pin (51) and washer (55). Save only four cap screws (34) for re-use.
- 4f. Position the spacer (17) over the valve stem (7 Ranger, 3.2 Premier) end, oriented as shown in Figure 2.5.
- 4g. Put Loctite #242 thread locking sealant, or equal, onto the setscrew (77). Engage the setscrew (77) into the tapped end of the spacer (17), until the setscrew (77) is projecting out of the spacer (17) 3/16"-1/4" (5-6 mm).
- 4h. Position bearing (18) over the spacer (17) and push fully inwards.
- 4i. Position cover plate (13) over bearing (18) ensuring that cover plate (13) gets properly centered and shouldered within the arm housing (4). Align the four bolt holes within the arm housing (4). Engage the cap screws (34) to secure the cover plate (13) to the arm housing (4), tightening cap screws (34) evenly.
NOTE: It may be necessary to rotate the actuator manual handwheel operator (58) downwards, or alternately supply a small level of air pressure (5-7 psig), (0.35-0.50 Barg) to assist in properly shoulder-

ing the cover plate (13) within the arm housing (4).

5. Rotate handwheel operator (58) until slack, or release all air pressure from the actuator.
6. Position mounting bracket (76) onto the positioner base plate (26) and secure with four cap screws (79). The bracket should end up with four holes to mount the positioner unit and its baseplate (26) as shown in Figure 2.8.

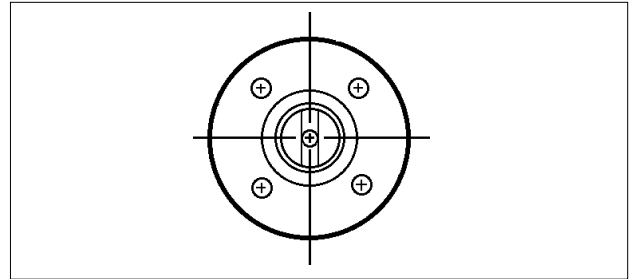

Figure 2.8

VDI/VDE #3845 Positioner Mounting Bracket

7. Attach the baseplate and mounting bracket (76) assembly to housing cover (13) using four cap screws (78). Align baseplate (26) to be parallel with bottom of valve's arm housing (4). See III.C. **NOTE:** Engage the tongue-and-groove joint between the positioner baseplate rotary shaft (32) and the spacer (17) with its protruding set screw (77).
8. Determine characterization cam's (24) proper orientation as indicated in Figures 8 thru 15; cut a spacer from wood or heavy cardboard to the dimension "X" indicated.
NOTE: Whether air-to-open (ATO) or air-to-close (ATC), Cashco's Ranger QCT, Premier (unlined) or Premier EZO all rotate clockwise (CW) to "close" valve, or counter clockwise (CCW) to "open" valve, when viewed from stem (7) end.
9. Place a thin film of adhesive, glue or pipe thread sealant on the "back" side of cam (24) to secure toothed lock washer (28) to cam (24). Use post end screw (23) to correctly align centers of these three parts (24, 27 & 28); do not allow the post-end screw (23) to adhere to these parts.
10. Using the spacer of Step 8., position cam (24) with adhered parts (27 & 28) up to the end of positioner rotary shaft (32). Carefully screw-in post-end screw (23) while holding cam (24) in its approximate position. Hand-tighten post-end screw (23) until certain that the washers (27 & 28) have remained in alignment. (If washers (27 & 28) are misaligned, the cam (24) will not be able to be secured.)
11. Procedure now follows IOM-9520R (10-93) or IOM-9540R (8-89), starting with III.D.9.

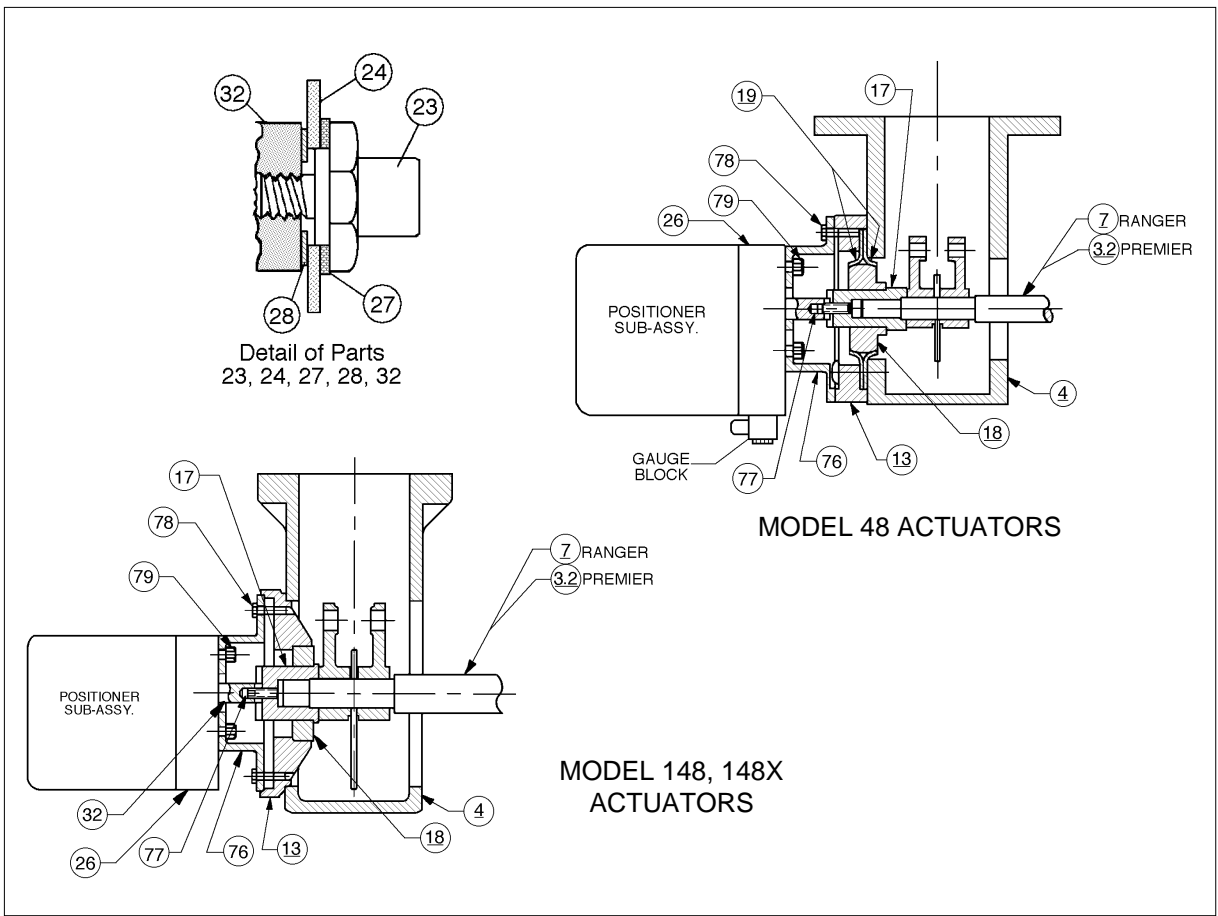

Figure 3