

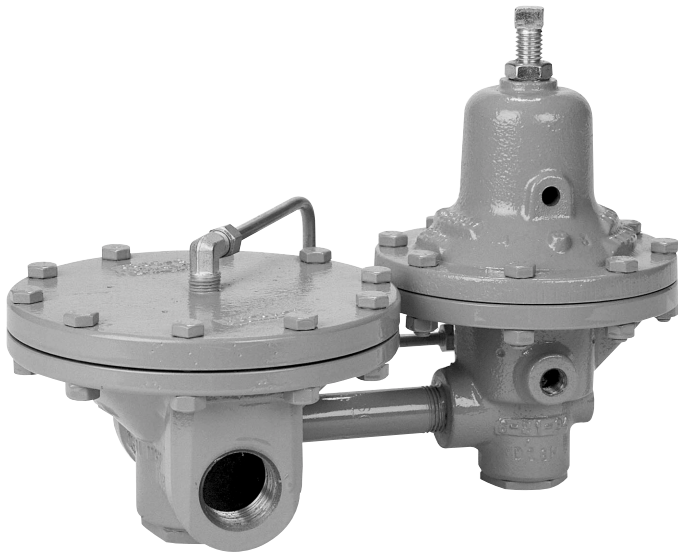

MODEL POSR-1

PRESSURE REDUCING REGULATOR PILOT OPERATED



MODEL POSR-1

The Model POSR-1 is a pilot operated regulator primarily for use with steam. The external pilot valve is supplied from a main valve body tapped connection. Sizes are 1/2", 3/4" and 1" (DN15, 20 and 25). Handles pressure drops up to 200 psi with adjustable outlet pressures between 5 and 150 psig. Also available without the pilot as a pressure loaded regulator.

FEATURES

- Hardened Trim:** 416 SST hardened pilot and main valve trim for long life.
- Bellows Seal:** The pilot uses a bellows as a frictionless seal for the pilot valve plug. It was incorporated to ensure that the pilot maintains its sensitivity and smooth operation in older steam systems that are chemically treated and systems that are used intermittently.
- High Sensitivity:** Four pilot range springs provide high sensitivity and contribute to the valve's excellent stability.
- Two Body Materials:** Ductile iron or cast steel.
- Easy to Install:** A 1/4" NPT sensing line and the valve body are the only connections required.

APPLICATIONS

Primarily used in steam heating in hospitals, hotels, motels, office buildings, factories, apartment buildings, warehouses, shopping malls, green houses, university buildings, sport complexes and airports.

Used on stills, cookers, dryers, presses, pasteurizers, purifiers, sterilizers, mangles, washers, rendering machines, bleachers, vulcanizers, oil heaters, molding machines, steam jacketed equipment, kilns, retorts, heat exchangers, paper and board machines, steam driven auxiliaries, blowers, pumps and centrifuges.

**STEAM SERVICE
ONLY**

STANDARD/GENERAL SPECIFICATIONS

Body Sizes: 1/2", 3/4" and 1" (DN15, 20 and 25).

End Connections: NPT female.

Unit Materials: See Table 1 for material specifications.
Main Valve – DI or CS.
Pilot Valve – DI body, CI or CS spring chamber.

CI = Cast Iron
 CS = Carbon Steel
 DI = Ductile Iron

Maximum Inlet Pressure: 300 psig (20.7 Barg), all materials.

Maximum Inlet Temperature: 450°F (232°C).

Outlet Pressure Range: 5-150 psig (0.34-10.3 Barg) in four range springs. See Table 2.

Pressure Drop Limits: Maximum – 200 psid (13.8 Bard).
Minimum – 15 psid (1.0 Bard)

Maximum Emergency Outlet Pressure: Function of spring range –
 5-15 psig (0.34-1.03 Barg),
 100 psig (6.9 Barg).
All other spring ranges –
 200 psig (13.8 Barg).

Capacity: See Table 5. Up to 5.5 Cv (4.7 Kv), with Droop @ 10%.

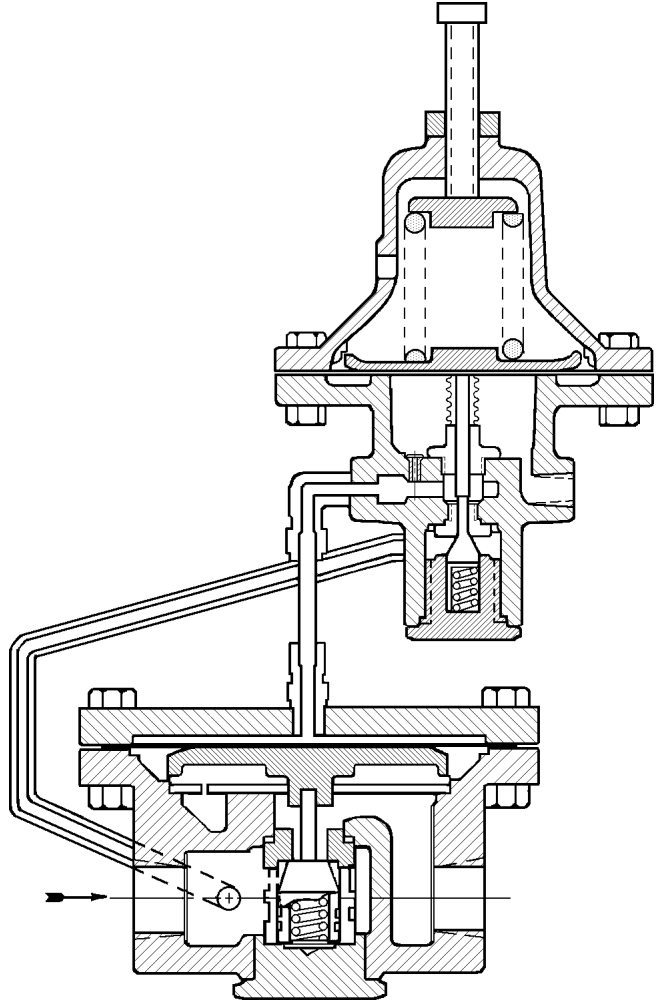

Figure 1: POSR-1

MAIN VALVE MATERIAL SPECIFICATIONS

Body: DI – ASTM A395
 CS – ASTM A216, Gr. WCB.

Loading Chamber: DI – ASTM A395.

Body Cap: SST – ASTM A582, Tp. 416.

Diaphragm Bolting: Plated steel.

Diaphragm Gasket: Graphite NBR.

Interconnection Pipe & Fittings: Pipe: ASTM A53, Gr. B, or ASTM A106, Gr. B carbon steel.
Fittings: 300# malleable iron, per ANSI B16.3.

Tubing & Fittings: Annealed copper tube and brass "bite-type" compression fittings.

Internal Trim: See Table 4. Trim Designation No. "S2".

PILOT VALVE MATERIAL SPECIFICATIONS

Body:	DI – ASTM A395.	Pressure Plate:	Cast iron.
Spring Chamber:	CI – ASTM A126, Class B. CS – ASTM A216, Gr. WCB.	Spring Button:	Cast iron.
Body Cap:	SST – ASTM A582, Tp. 416.	Range Springs:	Epoxy coated steel.
Diaphragm Bolting:	Plated steel.	Adjusting Screw & Lock Nut:	Plated steel.
Diaphragm Gasket:	Graphite NBR.	Internal Trim:	See Table 4. Trim Designation No. "S2".

OPTION SPECIFICATIONS

- Option -3:** HAND WHEEL & LOCKING LEVER. Utilize when pressure setting changes are frequent.
- Option-20:** PRESSURE LOADED REDUCER. Main valve body only; i.e. no pilot valve. Allows for remote control or programmed control in batching operations. May even be loaded with air from an I/P transducer. See Table 6 for flow capacity. **NOTE:** There is an inlet (P_1) pressure influence on the outlet pressure if the P_1 pressure varies. See Figure 2.

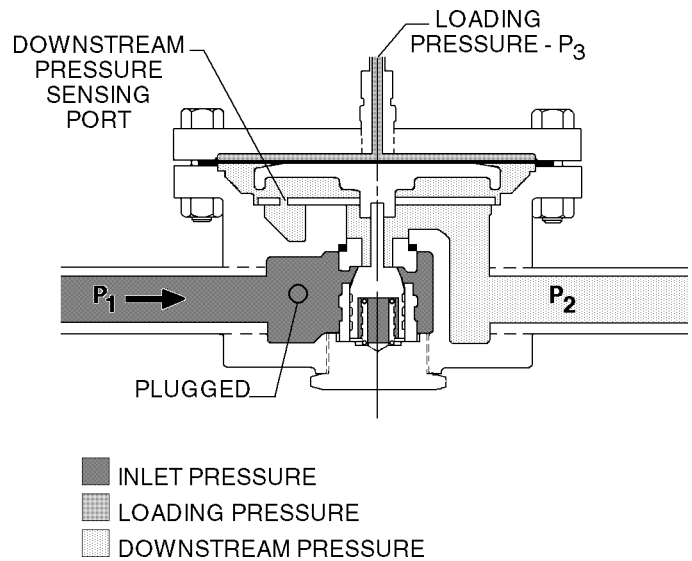

Figure 2: POSR-1-20

Outlet Pressure - P_2 psig (Barg)		Loading Pressure - P_3 , psig (Barg)			
		@ P_1 Minimum		@ P_1 Maximum	
5	(0.34)	15	(1.03)	25	(1.7)
50	(3.45)	60	(4.1)	70	(4.8)
100	(6.90)	110	(7.6)	120	(8.3)
130	(8.97)	145	(10.0)	150	(10.3)
135	(9.31)	150	(10.3)	—	—

Option-56: SPECIAL CLEANING. Cleaning per Cashco Spec #S-1542. Higher degree of cleaning than the standard commercial cleaning.

Option-95: EPOXY PAINTED. Two-step epoxy coated for severe ambient conditions to minimize external corrosion. Applied to all exposed parts except those of SST, copper and brass. Procedures and specifications per Cashco spec #S-1547.

PRINCIPLES OF OPERATION

The POSR-1 pilot obtains its operating medium from the main valve body inlet pressure P_1 of the regulator. Downstream pressure P_2 registers on the underside of the main valve's diaphragm and the pilot valve's diaphragm.

The loading pressure on the main valve's diaphragm is higher than the downstream P_2 pressure by the sum of the pressures required to overcome the main valve's plug unbalance force and the plug's spring force.

The pilot has a downstream bleed orifice that bleeds part of the loading medium downstream. In operation, the pilot valve's plug can flow more medium than is bled downstream. This increases the loading pressure on the main valve's diaphragm which increases the opening of the valve's plug. Partially closing the pilot valve's plug will reduce its flow to less than the amount bleeding downstream, and allows the loading pressure on the main

valve's diaphragm to decay, causing the diaphragm to rise and allowing partial closing of the main valve's plug.

The pilot valve's diaphragm senses the downstream P_2 pressure and compares the force generated to the force developed by the pilot's range spring.

If during operation the downstream P_2 pressure falls below the setpoint, the main valve's diaphragm senses the reduced pressure on its underside and instantly moves down. This opens the main valve's plug further. At the same time, the pilot senses the reduced pressure and the pilot valve's plug increases its opening. This action elevates the loading pressure on the upper side of the main valve's diaphragm, opens the main valve's plug more and increases flow enough to restore the downstream P_2

pressure to the setpoint.

If the downstream P_2 pressure rises above the setpoint, the main valve's diaphragm instantly moves upward and allows the plug's spring to partially close the main valve's plug. Meanwhile, the pilot valve's plug partially closes and allows the loading pressure to decay. The main valve's diaphragm moves upward with the reduced loading pressure and closes the main valve's plug enough to restore the downstream P_2 pressure to the setpoint.

Pressure setpoint is adjusted by changing the compression of the pilot's range spring. Compressing the range spring will increase the downstream P_2 pressure. Relaxing the range spring decreases the downstream P_2 pressure. See Figure 3.

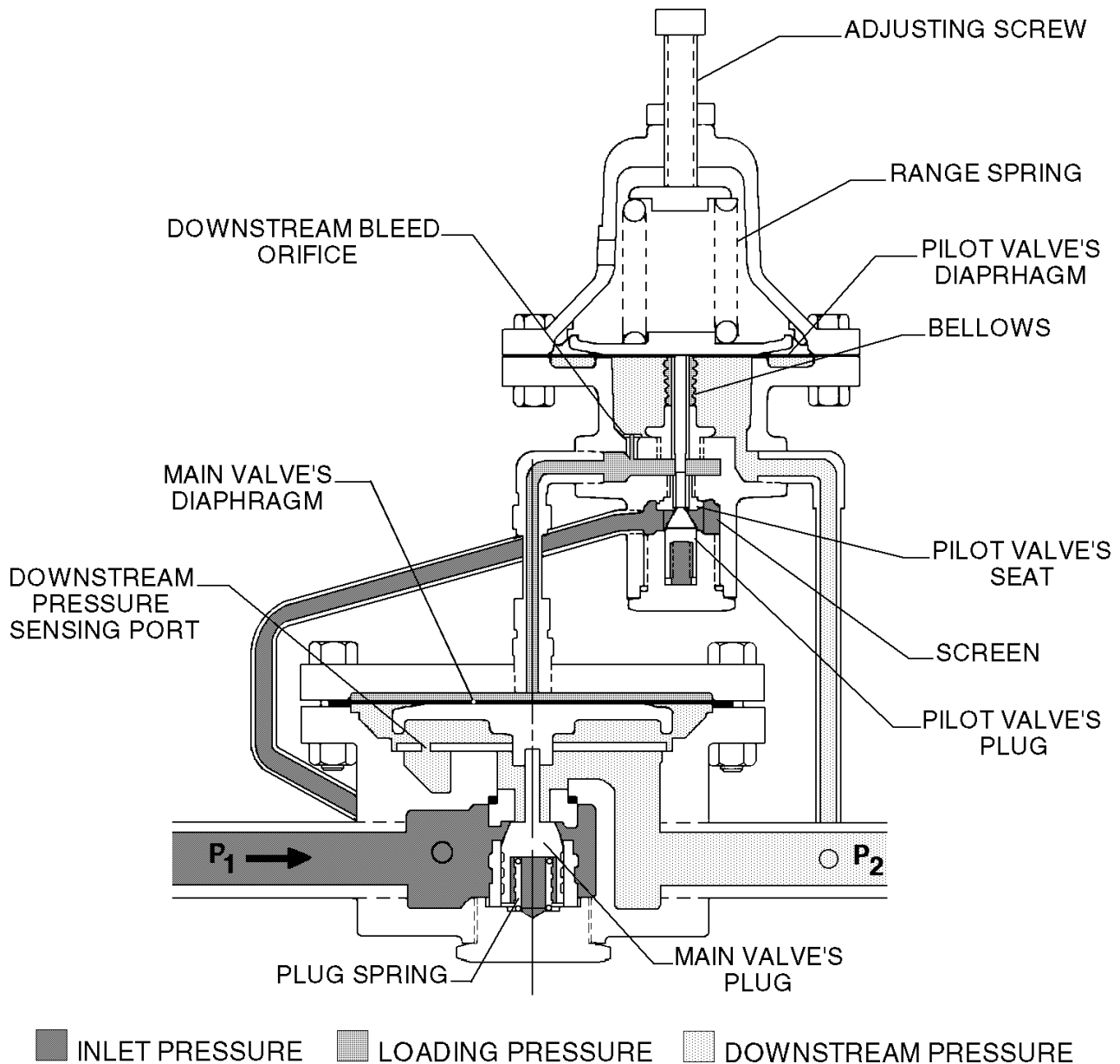

Figure 3

PRINCIPLES OF OPERATION

The following procedure will help determine a suitable selection for an application.

- STEP 1. **FOUR KNOWNs.** The following minimal parameters/data must be available before a selection procedure can begin:
- a. Inlet Pressure – P_1 (upstream pressure), weight density.
 - b. Outlet Pressure – P_2 (downstream pressure). How much can P_2 vary as flow varies; i.e. acceptable “droop”.
 - c. Desired Capacity – C_v , #/Hr; minimum and maximum.
 - d. Steam Temperature – T_1 , saturated, degrees superheat, actual temperature; weight density.

- STEP 2. **INLET PRESSURE AND TEMPERATURE.** Ensure that the actual design inlet pressure and temperature limits do not exceed the limits established in Table 1 for the materials being applied.

- STEP 3. **OUTLET PRESSURE.** There is a separate P vs. T rating for outlet of the POSR-1, with the outlet rating being lower; see limits established in Table 1.

All pilot operated pressure reducing regulators “droop” or “falloff” from a setpoint pressure level at a given flow as the flow rate increases. This deviation in setpoint is described as “% droop”. Droop is expressed on increasing flow, starting from a minimum flow level.

The “% droop” must be known to enter the capacity tables. The acceptable level of setpoint deviation should be known for the min-to-max flow variations.

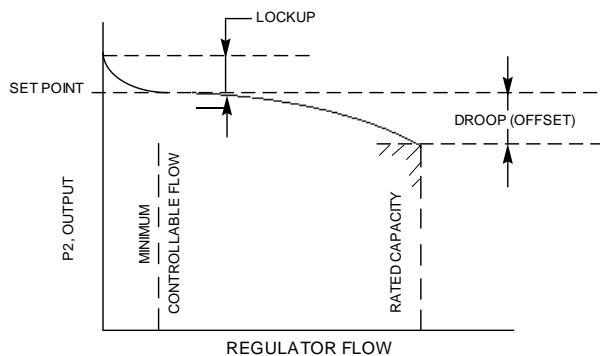

A regulator may have a setpoint up to 15% below the lower stated range spring level. (Tags will show the standard ranges.) A setpoint above the higher range spring level is not recommended. Setpoint at the upper limit of a range spring is acceptable. If final setpoint is questionable and expected near the upper limit, the next higher range spring should be utilized. Best performance will be obtained when the lowest range spring is utilized.

See Table 1 for outlet pressure, operating pressure and emergency overpressure levels. Reaching the emergency overpressure levels may cause internal damage to the pilot or main valve, requiring maintenance.

- STEP 4. **PRESSURE DROP.** Maximum $\Delta P = 200$ psid (13.8 Bard) for all body sizes. Minimum $\Delta P = 15$ psid (1.03 Bard) for all body sizes. Do not exceed or go below these limits.

- STEP 5. **CAPACITY.** With the four knowns of Step 1, calculate the C_v Required. Consult your Cashco Sales Representative for sizing, selection and noise prediction by computer. **Alternate** – Using the flow rate and pressures, enter Table 5 to find the body size capable of passing the required flow rate.

For pressure loaded (Opt-20, no pilot valve) applications, use Table 6 to find the body size capable of passing the required flow rate.

- STEP 6. **SAFETY RELIEF VALVE.** A downstream safety relief is recommended for main or pilot valve internals failure. If flow is isolated downstream (not recommended), a sentinel relief valve must be provided to relieve seat leakage buildup.

TECHNICAL SPECIFICATIONS

TABLE 1 DESIGN PRESSURE-TEMPERATURE MATERIAL SPECIFICATIONS

Material Specifications				Main Valve End Conns.	Inlet		* Operating Pressure	Outlet	
								** Emergency Overpressure Spring Range	
Main Valve		Pilot Valve			Pressure	Temp		10-40 psig 30-80 psig 70-150 psig	5-15 psig
Descrip. (Abbr.)	ASTM No.	Descrip. (Abbr.)	ASTM No.	psig (Barg)	°F (°C)	psig (Barg)	psig (Barg)		
DI/DI	A395/ A395	DI/CI	A395/ A126, Cl. B	300# NPT	300 (20.7)	450 (232)	1.10 x UVRS up to 150 psig (up to 10.3 Barg)	150 (10.3)	100 (6.9)
CS/CI	A216, Gr. WCB/ A126, Cl. B	DI/CI	A395/ A126, Cl. B	300# NPT	300 (20.7)	450 (232)	1.10 x UVRS up to 150 psig (up to 10.3 Barg)	150 (10.3)	100 (6.9)
		DI/CS	A395/A216, Gr. WCB	300# NPT	300 (20.7)	450 (232)		200 (13.8)	100 (6.9)

* Limit is the lower pressure value of 125/150 psig (8.6/10.3 Barg), or the factor x UVRS (UVRS - "Upper Value of Range Spring"). Example: Steel body – for a 30-80 psig (2.1-5.5 Barg) standard range spring, the 1.10 x UVRS value = 1.10 x 80 = 88 psig; 88 < 150, therefore pressure limit = 88 psig (1.10 x 5.5 = 6.1 Barg; 6.1 < 10.3, therefore pressure limit = 6.1 Barg).

** Emergency Overpressure: Safety relief valve $P_{setpoint} + P_{accumulation}$ must not exceed this pressure level.

NOTE: All outlet temperature levels are thermodynamically determined by the maximum inlet pressure/temperature conditions.

TABLE 2 RANGE SPRINGS

Outlet Range		Emergency Overpressure	
psig	(Barg)	psig	(Barg)
5-15	(.34-1.03)	100	(6.9)
10-40	(.69-2.8)	200	(13.8)
30-80	(2.1-5.5)		
70-150	(4.8-10.3)		

TABLE 3 MAXIMUM Cv WITH PLUG WIDE OPEN (Use for Safety Relief Valve Sizing)

Body Size		Max Cv
in	(mm)	
1/2"	(DN15)	3.4
3/4"	(DN20)	3.8
1"	(DN25)	5.8

TABLE 4 TRIM MATERIALS - TRIM DESIGNATION NOS.

Trim Designation No.	Valve Portion	Part Description	Trim Material
S2	Main	Plug	416 SST – hardened *
		Cylinder (seat)	416 SST – hardened *
		Plug Spring	302 SST
		Diaphragm(s)	302 SST
		Cylinder Gasket	Grafoil
		Pusher Plate	Cast Iron
		Shield & Screw	18-8 SST
	Pilot	Plug	416 SST – hardened *
		Seat	416 SST – hardened *
		Plug Spring	302 SST
		Stem Extension	416 SST
		Bellows Assembly	Brass/Bronze
		Screen	316 SST
		Diaphragm(s)	302 SST
Seat Gasket	Annealed Copper		

* Hardness – Rc ≈ 35 to 39.

**TABLE 5
STEAM CAPACITIES IN LBS/HR; SATURATED STEAM**

OUTLET PRESSURE P2, psig	INLET PRESSURE P1, psig	PRESSURE DROP psi	#/HR @ 1/2" BODY SIZE				#/HR @ 3/4" BODY SIZE				#/HR @ 1" BODY SIZE			
			DROOP				DROOP				DROOP			
			2.5%	5.0%	7.5%	10.0%	2.5%	5.0%	7.5%	10.0%	2.5%	5.0%	7.5%	10.0%
10	25	15	47	93	140	187	54	109	163	218	86	171	256	342
	50	40	82	165	247	329	96	192	288	384	151	302	453	604
	75	65	115	231	346	461	135	269	404	538	211	423	634	846
	100	90	210	450	510	600	245	525	595	700	385	825	935	1100
	125	115	327	654	691	727	382	763	806	848	600	1199	1266	1333
	150	140	392	783	819	853	458	913	955	995	719	1435	1501	1563
	175	165	461	916	950	980	537	1069	1109	1143	844	1679	1742	1796
200	190	520	1035	1074	1107	607	1207	1252	1291	954	1897	1968	2029	
15	50	35	81	162	243	324	95	189	283	378	148	297	445	594
	75	60	114	227	341	454	133	265	398	530	208	416	625	833
	100	85	208	445	504	593	242	519	588	692	381	816	924	1088
	125	110	327	654	691	727	382	763	806	848	600	1199	1266	1333
	150	135	392	783	819	853	458	913	955	995	719	1435	1501	1563
	175	160	461	916	950	980	537	1069	1109	1143	844	1679	1742	1796
	200	185	520	1035	1074	1107	607	1207	1252	1291	954	1897	1968	2029
20	50	30	79	157	236	315	92	184	275	367	144	288	433	577
	75	55	113	226	339	452	132	264	395	527	207	414	621	828
	100	80	202	434	492	578	236	506	573	675	371	795	901	1060
	125	105	326	651	688	724	380	760	802	844	597	1194	1261	1327
	150	130	392	783	819	853	458	913	955	995	719	1435	1501	1563
	175	155	461	916	950	980	537	1069	1109	1143	844	1679	1742	1796
	200	180	520	1035	1074	1107	607	1207	1252	1291	954	1897	1968	2029
25	50	25	75	150	225	301	88	175	263	351	138	276	413	551
	75	50	112	223	335	447	130	261	391	521	205	409	614	819
	100	75	202	433	491	577	236	505	572	673	370	794	899	1058
	125	100	318	636	671	706	371	742	783	824	583	1166	1230	1295
	150	125	392	783	819	853	458	913	955	995	719	1435	1501	1563
	175	150	461	916	950	980	537	1069	1109	1143	844	1679	1742	1796
	200	175	520	1035	1074	1107	607	1207	1252	1291	954	1897	1968	2029
35	50	15	63	127	190	254	74	148	222	296	116	233	349	465
	75	40	107	214	321	428	125	250	375	499	196	392	589	785
	100	65	142	285	427	569	166	332	498	664	261	522	783	1044
	125	90	245	524	594	699	285	611	693	815	448	961	1089	1281
	150	115	370	740	781	822	432	863	911	959	678	1356	1432	1507
	175	140	445	887	928	967	519	1035	1083	1128	815	1627	1701	1772
	200	165	520	1035	1074	1107	607	1207	1252	1291	954	1897	1968	2029
50	75	25	93	186	279	372	109	217	326	434	171	341	512	683
	100	50	135	271	406	542	158	316	474	632	248	496	745	993
	125	75	240	513	582	684	279	599	679	798	439	941	1066	1255
	150	100	367	734	775	816	428	857	904	952	673	1346	1421	1495
	175	125	434	866	905	943	506	1010	1056	1100	795	1587	1659	1728
	200	150	501	997	1035	1067	585	1164	1207	1244	919	1828	1897	1956
	250	200	651	1316	1337	1357	760	1536	1560	1583	1194	2413	2451	2488
75	100	25	108	216	324	433	126	252	379	505	198	397	595	793
	125	50	156	311	467	622	182	363	544	726	285	570	855	1141
	150	75	272	583	661	778	318	680	771	907	499	1069	1212	1426
	175	100	414	828	874	920	483	966	1019	1073	759	1517	1602	1686
	200	125	485	967	1012	1054	566	1129	1180	1229	889	1774	1855	1932
	250	175	615	1223	1269	1308	717	1427	1481	1526	1127	2243	2327	2399
100	125	25	121	242	364	485	141	283	424	566	222	444	667	889
	150	50	173	347	520	693	202	404	606	808	318	635	953	1270
	175	75	302	647	733	862	352	755	855	1006	553	1186	1344	1581
	200	100	456	913	963	1014	532	1065	1124	1183	837	1673	1766	1859
	250	150	606	1206	1251	1290	707	1407	1460	1505	1112	2211	2294	2365
	300	200	744	1503	1526	1549	868	1753	1780	1807	1363	2755	2798	2840
125	150	25	133	266	398	531	155	310	465	620	243	487	730	974
	175	50	190	379	569	758	221	442	663	885	348	695	1043	1390
	200	75	329	705	799	940	384	823	932	1097	603	1293	1465	1724
	250	125	575	1147	1199	1249	671	1338	1399	1458	1054	2103	2199	2291
	300	175	718	1428	1481	1527	837	1666	1728	1781	1316	2617	2715	2799
150	175	25	144	287	431	574	168	335	503	670	263	526	790	1053
	200	50	205	409	614	818	239	477	716	955	375	750	1125	1500
	250	100	532	1064	1123	1182	620	1241	1310	1379	975	1950	2058	2167
	300	150	698	1389	1441	1486	815	1621	1681	1733	1280	2547	2642	2724

NOTE: Shaded values indicate that the outlet flow has reached/exceeded Mach 0.35.

**TABLE 6
PRESSURE LOADED POSR-1-20 MAIN VALVE
STEAM CAPACITIES IN LBS/HR
SATURATED STEAM**

Flowing Outlet Pressure * psig	Inlet Pressure psig	1/2" Body	3/4" Body	1" Body
5	20	140	150	220
	30	180	220	250
	50	210	260	270
	75	210	290	330
	100	210	300	360
	150	210	300	360
10	200	210	300	360
	25	180	190	270
	30	200	200	310
	50	240	260	310
	75	240	300	360
	100	240	300	400
15	150	240	300	440
	200	240	300	460
	30	190	200	260
	50	240	280	340
	75	240	330	420
	100	250	360	440
25	150	270	360	500
	200	320	360	500
	40	230	240	340
	50	260	300	390
	75	270	360	450
	100	310	400	520
35	150	340	400	580
	200	340	400	600
	225	340	400	630
	50	260	270	420
	75	340	370	490
	100	340	450	610
50	150	380	460	680
	200	400	460	680
	225	400	460	680
	65	300	310	510
	75	370	390	610
	100	400	510	720
75	150	450	600	840
	200	500	640	920
	250	570	660	920
	100	400	460	780
100	150	730	860	1100
	200	730	910	1100
	250	730	920	1100
	125	500	530	870
	150	720	740	1300
100	200	910	1000	1400
	250	950	1200	1400
	300	980	1200	1400

NOTE: Many of the above capacities meet or exceed the velocities recommended for piping. Use reducers and larger pipe to reduce the velocities to acceptable limits.

* Pressure increases 20% when flow is reduced to 2% of published figures, except the 5 to 15 psig range has an increase of 4 psig.

DIMENSIONS & WEIGHT

POSR-1, Sizes 1/2", 3/4" and 1" (DN15, 20 & 25)

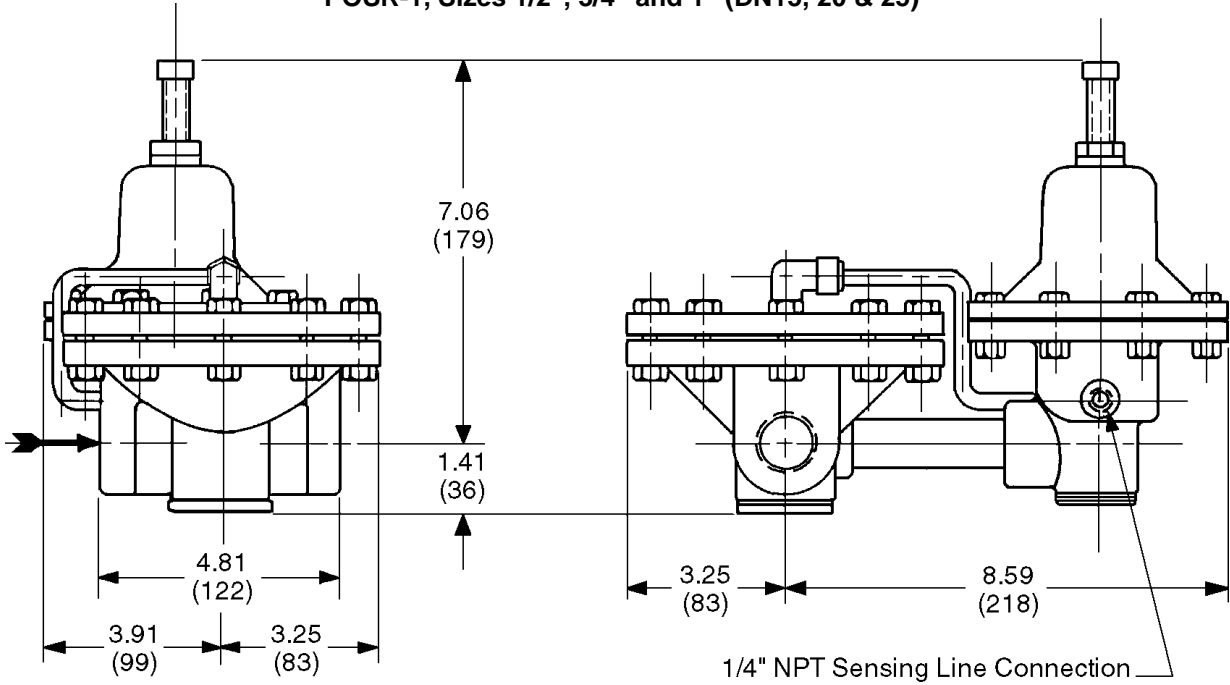

WEIGHT FOR POSR-1 IS APPROX. 27 LBS. (12 KG)

All dimensions in inches with mm in ()

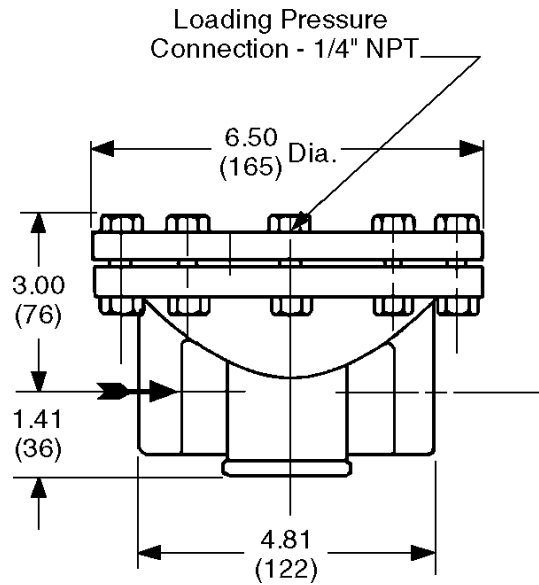

POSR-1-20
Pressure Loaded Main Valve

WEIGHT FOR POSR-1-20 IS APPROX. 18 LBS (8.2 KG)

NOTES

NOTES

TABLE 3

MAIN VALVE BODY/LOAD CHAMBER	PILOT VALVE BODY/SPRING CHAMBER	CODE
DI/DI	DI/IR	1
CS/DI	DI/IR	2
CS/DI	DI/CS	5

TABLE 2

SIZE	CODE
1/2"	4
3/4"	5
1"	6

TABLE 1

SERVICE*	GASKETS	OPTIONS	CODE
Basic (Above -20°F)	Std. - Non-Asbestos	—	B

* Refer to Tech Bulletin for complete temperature range.

Materials

Service &
Gaskets

Size

Trim
Designation

NPT
Connections

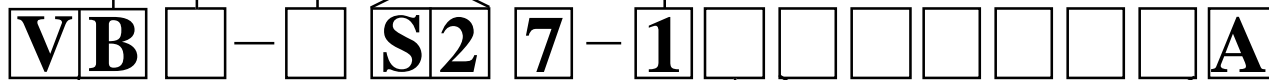

**MODEL "POSR-1" PILOT OPERATED
PRESSURE REDUCING REGULATOR**

Options

TABLE 4

RANGE SPRING (psig)	CODE
5-15	1
10-40	2
30-80	3
70-150	4
Option-20 * Pressure Loaded	Y

* Must specify in Table 5.

Range Spring

ASSIGNMENT OF "OPTION" CODES

1. When ordering a valve per one of Cashco's special drawings, the code "X" and the 5-digit number following override all other options. Otherwise, proceed with the following.
2. NUMERIC digits assigned first in "ascending" order.
3. ALPHA designations are assigned second (excluding the "X") in "alphabetical" order.
4. Left justify.
5. Add "0" to all unused squares.
6. If insufficient quantity of squares, consult factory for proper code.

TABLE 5

DESCRIPTION	OPT.	CODE
Special Construction	—	X
Handwheel & Lock Lever	-3	3
Pressure Loaded	-20	B
Special Cleaning #S-1542	-56	N
Epoxy Paint	-95	W

Cashco, Inc.
P.O. Box 6
Ellsworth, KS 67439
PH: (785) 472-4461
FAX: (785) 472-3539
E-mail: sales@cashco.com
exportsales@cashco.com