



MODEL POSR-2

PILOT OPERATED PRESSURE REDUCING REGULATOR

SECTION I

I. DESCRIPTION AND SCOPE

The POSR-2 is a pilot operated pressure reducing regulator used to control downstream (P_2) pressure. Sizes are 1", 1-1/2", 2", 3" and 4" (DN25, 40, 50, 80, 100). The unit is suitable for steam service only. Refer to Technical Bulletin POSR-2-TB for design conditions and selection recommendations. **NOT RECOMMENDED FOR DEAD END SERVICE.**

SECTION II

II. INSTALLATION

A. General:

WARNING

Do not dead end (no flow demand) downstream of POSR-2 if P_1 - Inlet Pressure is greater than maximum allowable outlet design pressure.

| Spring Range | Max. Allowable Outlet Pressure |
|-----------------------------|--------------------------------|
| 5-15 psig (0.34–1.03 Barg) | 100 psig (6.9 Barg) |
| 10–40 psig (0.69–2.8 Barg) | 200 psig (13.8 Barg) |
| 30–80 psig (2.1–5.5 Barg) | 200 psig (13.8 Barg) |
| 70–150 psig (4.8–10.3 Barg) | 200 psig (13.8 Barg) |

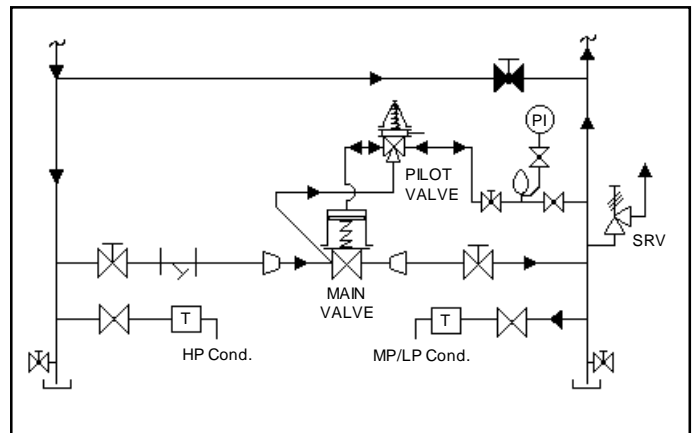

FIGURE 1
Recommended Piping Schematic for POSR-2

B. Piping the Valve:

1. An inlet block valve should always be installed.
2. If service application is continuous such that shut down is not readily accomplished, it is recommended that an inlet block valve, outlet block valve, and a manual bypass valve be installed.
3. Pipe unions are recommended for NPT screwed installations to allow removal from piping.
4. An outlet pressure gauge should be located approximately ten pipe diameters downstream, and within sight.
5. All installations should include a downstream relief device if the inlet pressure could exceed the pressure rating of any downstream equipment or the maximum allowable outlet pressure rating of the unit.
6. Clean the piping of all foreign material including chips, welding scale, oil, grease and dirt before installing the regulator. Strainers are recommended.





CAUTION

DO NOT HYDROSTATIC TEST THROUGH AN INSTALLED UNIT, INCLUDING PILOT; ISOLATE BOTH PILOT AND MAIN VALVE FROM TEST. The upper range spring pressure level listed on the nameplate is the recommended "upper operative limit" for the sensing diaphragm(s) in the pilot. Higher pressures could cause internal damage. In addition, note on the nameplate that the Inlet and Outlet pressure and temperature ratings are at different levels.

7. In placing thread sealant on pipe ends prior to engagement, assure that excess material is removed and not allowed to enter the regulator upon start-up.
8. Flow Direction. Install so the flow direction matches the flow arrow on the body.
9. The POSR-2 comes factory piped between the pilot supply and pilot loading. Install an external sensing line from the 1/4" NPT connection opposite the factory piped pilot loading port to a point downstream at gauge location; use 1/4" OD metal tubing for distances 4 ft (1.2 m) or less, and 3/8" OD metal tubing (requires 1/4" x 3/8" tubing adapter) for distances greater than 4 ft. (1.2 m). The sensing line should always be sloped downward so that condensation will drain away

from the pilot. If regulator pipe line is expanding to a larger pipe line, always connect sensing line to the larger pipe line.

10. See Figure 2 for installation orientation for horizontal or vertical piping. For best performance Cashco recommends installing in a well drained horizontal pipe, properly trapped.

Position "H": Horizontal Pipe. Requires user to install sensing line on downstream piping.

Position "VD": Vertical pipe with downwards flow direction. Requires user to install sensing line on downstream piping.

Position "VU": Vertical pipe with upwards flow direction. Pilot valve and main valve shipped as separate units. Requires user to install pilot valve at downstream pipe tap with a pipe nipple (not provided), provide and install tubing (4 tube fittings and two 4 ft (1.2 m) lengths of 1/4" OD copper tubing supplied) to loading chamber tap and to P₁ body tap from pilot valve.

11. Recommended installation is with pilot valve spring chamber vertical upwards. Orient such that the spring chamber vent hole does not collect rainwater or debris.
12. Regulators are not to be buried underground.
13. For insulated piping systems, recommendation is to not insulate regulator.

SECTION III

III. PRINCIPLE OF OPERATION

A. General:

1. The POSR-2 pilot obtains its operating medium from the main valve body inlet. Downstream pressure (P₂) registers on the underside of the main valve's piston and the pilot valve's diaphragm(s).
2. The loading pressure on the top side of the main valve's piston is an intermediate pressure higher than the downstream (P₂) pressure by the sum of the pressures required to overcome the main valve's plug unbalance force and the piston spring's force.
3. The pilot has a bleed orifice that continuously

bleeds part of the loading medium downstream. In operation, the pilot valve's plug can flow more medium than is bleeding downstream. This increases the loading pressure on the main valve's plug and opens valve. Partially closing the pilot valve's plug will reduce its flow to less than the amount bleeding downstream, and allows the loading pressure on the main valve's piston to decay, allowing partial closing of the main valve's plug. This continues until steady-state is developed.

4. The pilot valve's diaphragm(s) senses the downstream (P₂) pressure and compares the force generated to the force developed by the pilot's range spring.

_____ Pipe or tubing installed by customer/installer.
 _____ Pipe or tubing installed by Cashco.

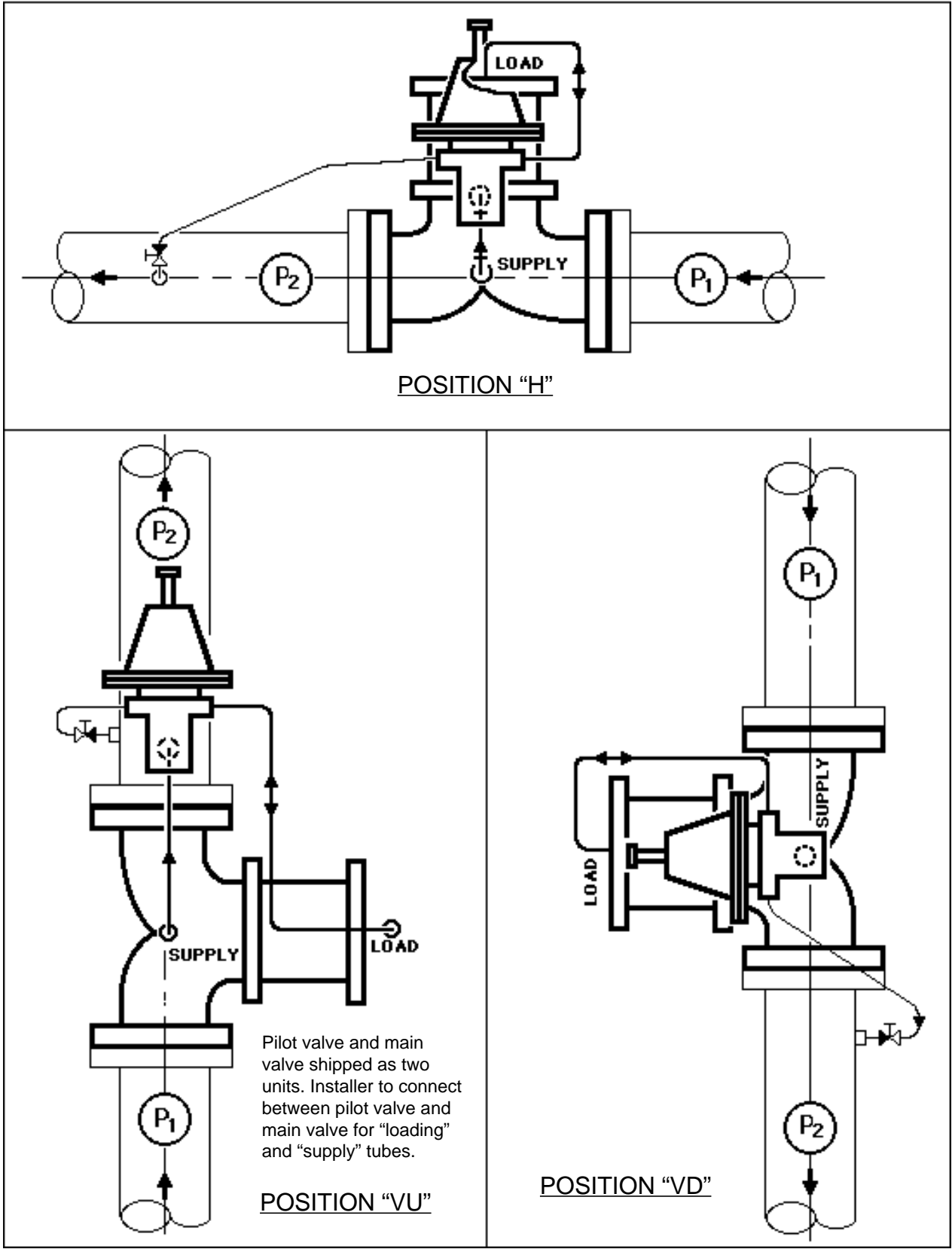

FIGURE 2
Orientation/Arrangement

5. If, during operation, the downstream (P_2) pressure falls below the pilot valve's setpoint, the main valve's piston senses the reduced pressure on its underside and instantly moves down, increasing the flow through the main valve. At the same time, the pilot valve senses the reduced pressure and the pilot valve's plug increases its opening, elevating the loading pressure on the upper side of the main valve's piston. The combined actions increase flow enough to restore the downstream (P_2) pressure to the setpoint.
6. If the downstream (P_2) pressure rises above the setpoint, the force developed by the increased pressure on the underside of the piston instantly moves it upward and partially

closes the main valve's plug. Simultaneously, the pilot valve's plug partially closes and allows the loading pressure to decay through the bleed orifice. The reduced loading pressure on the upper side of the piston closes the main valve's plug enough to restore the downstream (P_2) pressure to the setpoint.

7. Pressure setpoint is adjusted by changing the compression of the pilot's range spring by turning the adjusting screw either clockwise (CW) or counter-clockwise (CCW). Turning the adjusting screw clockwise (CW) will increase the downstream (P_2) pressure. Turning the adjusting screw counter-clockwise (CCW) will decrease the downstream (P_2) pressure.

SECTION IV

IV. START-UP

A. General

1. Start with the block valves closed.
2. Ensure that the needle valve(s) on the sensing line is opened and downstream (P_2) pressure is indicating on pressure gauge.
3. Relax the pilot valve range spring by turning the adjusting screw counter clockwise (CCW) (viewed from above) a minimum of three (3) full revolutions. This reduces the outlet (downstream) pressure setpoint.
4. Slowly open the bypass valve to preheat the system piping and to allow slow expansion of the piping. Assure proper steam trap operation. Closely monitor outlet (downstream) pressure via gauge to assure not over-pressurizing. **NOTE:** *If no bypass valve is installed, extra caution should be used in starting up a cold system; i.e. do everything slowly.*

gauge. Determine if the regulator is flowing. If not, slightly close bypass valve, and then slowly rotate the pilot valve adjusting screw clockwise (CW) (viewed from above) until flow begins.

7. Continue to alternate slowly closing the bypass valve and then slowly opening the inlet (upstream) block valve, especially when the downstream piping system isn't pressurized. If the outlet (downstream) pressure exceeds the desired pressure, close the bypass valve until fully closed. If outlet pressure still remains above desired level, rotate pilot's adjusting screw CCW (viewed from above) in 1/2 revolution increments until outlet pressure reaches desired level. If outlet pressure is below desired level, rotate pilot's adjusting screw CW (viewed from above) until desired level is reached.
8. When flow is established steady enough that the inlet (upstream) block valve is fully open, begin to slowly close the bypass valve and continue until fully closed.
9. Develop system flow to a level near its expected normal rate, and reset the regulator setpoint by turning the pilot valve adjusting screw CW (viewed from above) to increase outlet pressure, or CCW to reduce outlet pressure.
10. Reduce system flow to a minimum level and observe setpoint. Outlet pressure will rise from the setpoint of Step 9. There should be no more than a 10% variation in outlet pressure over the maximum to minimum flow range.



CAUTION

Do not walk away and leave a bypassed regulator unattended when on manual bypass!

5. Slowly open the outlet (downstream) block valve until fully open. Slightly close the bypass valve at same time.
6. Slowly open the inlet (upstream) block valve observing the outlet (downstream) pressure

SECTION V

V. SHUTDOWN

A. General

1. On systems with a bypass valve, and where system pressure is to be maintained as the POSR-2 is shut down, slowly open the bypass valve while closing the inlet (upstream) block valve. Fully close the inlet (upstream) block valve. (When on bypass, the system pressure must be constantly observed and manually regulated.) Close the outlet (downstream) block valve. Close the needle valve on the pilot valve's sensing line.



CAUTION

Do not walk away and leave a bypassed regulator unattended!

2. If the regulator and system are to both be shutdown, slowly close the inlet (upstream) block valve. Close the outlet (downstream) valve only if regulator removal is required. Close the needle valve on the pilot valve's sensing line.

SECTION VI

VI. MAINTENANCE



WARNING

SYSTEM UNDER PRESSURE. Prior to performing any maintenance, isolate the regulator from the system and relieve all pressure. Failure to do so could result in personal injury.

A. General:

1. Maintenance procedures hereinafter are based upon removal of the regulator unit from the pipeline where installed, and maintenance performed in a workshop.
2. Owner should refer to owner's procedures for removal, handling, cleaning and disposal of non-reuseable parts, i.e. gaskets, etc. Cashco recommends not reusing any gaskets, but replacing with only new and factory supplied gaskets.
3. This regulator is supplied from the factory using a gasket sealing aid, Federal Process Company, PLS 2, or equal. Such compatible sealing aids may be utilized by the Owner, if desired.
4. All indicated item numbers that are with respect to the Pilot Valve will be in parenthesis and underscored, i.e. (14), (PV). All item numbers that are with respect to the Main Valve will **NOT** be underscored, i.e. (1), (MV).

5. Refer to Figures 6 through 12 for item number callouts.
6. Most pilot-operated valve operation problems center around the pilot valve (PV). Cashco always recommends full maintenance on any POSR-2 pilot valve (PV) once a POSR-2 is removed from the pipeline.

B. Separation:

1. Observe orientation of pilot valve (PV) with respect to main valve (MV) position "VD", "H", or "VU", Figures 6, 7 or 8, before disassembling.
2. Place main valve body (1) into a vise, oriented to allow rotation of pilot valve (PV) together with interconnecting pipe nipple (19).
3. Remove loading tubing (21) at both end fittings (20) by rotating nut CCW (viewed from tube-end). Disengage union (28) where applicable and remove pilot valve (PV).
4. Place pipe wrench on pipe nipple (19) and rotate CCW (viewed from pilot valve (PV) end) to removal. Remove main valve (MV) from vise and set aside.
5. Place pilot valve body (1) in vise. Remove pipe nipple (19) or other pipe fittings (20, 27, 30) as is applicable.
6. Inspect the inside of the pipe and fittings for corrosion, scaling, debris, or filming. Problems here will be an indication of improper condensate corrosion control which can

6. (Cont.) affect the overall operation of the POSR-2. Install an upstream strainer if scale or debris appears at this point.
7. Remove pilot valve (PV) from vise and set aside.

C. Pilot Valve (PV):

1. Securely install the pilot valve body (1) in a vise with the spring chamber (2) directed upwards.

Using a putty knife or similar tool, remove diaphragm(s) (12) and diaphragm gasket (13). Inspect diaphragm(s) (12) for cracks or deformation. Radial creases and cracks indicate over pressure. Cracks circumferentially indicate high cycles, and may be due to normal cycling, or pulsing or chattering if premature. Discard both diaphragm(s) (12) and gasket (13).

8. Using a 7/8" deep well socket, remove bellows (11) by rotating CCW (viewed from above). Count and record the number of revolutions required to remove the bellows (11) in the box below:

| |
|--|
| Number of revolutions required to remove bellows (11):_____. |
|--|

Inspect the bellows (11) for a crack or joint failure where leakage is occurring. Replace bellows (11) if leaking.

 **WARNING**

SPRING UNDER COMPRESSION. Prior to removing body flange bolts, relieve spring compression by backing out the adjusting screw. Failure to do so may result in flying parts that could cause personal injury.

2. Loosen locknut (20) by rotating CCW (viewed from above) ONLY two revolutions. Relax range spring (15) by turning adjusting screw (19) CCW (viewed from above) until removed from spring chamber (2). Set adjusting screw (19) with locknut (20) aside.
3. Draw or embed a match mark between body casting (1) and spring chamber casting (2) along flanged area.
4. Remove all diaphragm flange nuts (18) and bolts (17).
5. Remove spring chamber (2) by lifting upwards. Remove range spring (15) and spring button (16).
6. Remove pressure plate(14). Inspect to ensure that the pressure plate (14) has not been deformed by overpressure by placing a thin, straight bar or ruler across the side that touches the diaphragm (12). If the pressure plate (14) does not touch the bar at its center (i.e. a depression in center), the pressure plate (14) is deformed and must be replaced.
7. NOTE: Pilot valves (PV) supplied with a 5–15 psig (0.34–1.03 Barg) range spring (15) have only one diaphragm (12) supplied; all other spring ranges use two diaphragms (12).

9. Remove protruding stem extension (10).
10. Using a flat, sharp-edged tool, clean body (1) flange where diaphragm gasket (13) seals.
11. Using a wire gauge tool, clean the 0.068" (1.73 mm) diameter bleed orifice located in the body cavity (smaller of two holes) of any film or other buildup material that might be restricting flow.

NOTE: Any significant blockage of the bleed orifice will downgrade a POSR-2's performance. If a buildup is forming, attempt to determine the cause and remove the source.

12. Remove body (1) from vise and reorient with body cap (9) on top; resecure body (1) in vise.
13. Remove body cap (9) by rotating CCW (viewed from above) with hex-end wrench. Hammer-rapping the wrench may be necessary, as the body cap (9) has a metal-to-metal shoulder joint with the body (1). **NOTE:** Plug (4.2) and plug spring (Z) may come out with body cap (9) removal.
14. Remove plug spring (Z) and plug (4.2) from body (1) recess.
15. Using needle nose pliers, carefully remove the screen (6) from the body (1) recess.

16. Inspect body cap (9), screen (6), plug spring (7), and plug (4.2) for buildup or filming. If parts are “sticking” together, then improper condensate corrosion treatment is likely. If scale or other debris is present, then an upstream strainer is recommended.
17. Using a 5/8" deepwell socket, rotate valve seat (4.1) CCW (viewed from above) to removal.
18. Remove seat gasket (8) using a tool with a bent sharp end. Discard the seat gasket (8).
19. Using a sharp edged tool, clean all gasket surfaces, and metal-to-metal contact surfaces of body (1), valve seat (4.1) and body cap (9).
20. Lap plug (4.2) with valve seat (4.1) using a suitable lapping compound. Do for new replacement plug (4.2) and seat (4.1) also.
21. Solvent clean all loose internal parts of pilot valve (PV). Inspect the valve seat (4.1) and plug (4.2) for wear. Replace the valve seat (4.1) and plug (4.2) together, even if only one piece shows significant wear. Solvent clean body (1).
22. Place body (1) into vise with body cap (9) opening upwards.
23. Place seat gasket (8) into recess.
24. Put thread lubricant onto valve seat (4.1), and rotate valve seat (4.1) into threaded recess by rotating CW (viewed from above) until seat (4.1) shoulders against body (1).
25. **NOTE: Replace screen (6) only if necessary.** Using a 3/4" (19 mm) round bar, form and interlock the flat screen (6) similar to the removed screen (6) being replaced. Slide formed screen (6) off of bar. Insert the screen into the body recess and over the hex points of the valve seat (4.1). Ensure concentricity of positioned screen (6).
26. Place plug spring (7) into recess of plug (4.2), and position plug's (4.2) stem-end through the valve seat (4.1).
27. Place thread lubricant on threads of body cap (9). Capture protruding plug (4.2) end and plug spring (7) with body cap (9) recess. Rotate body cap (9) CW (viewed from above) until shouldering on body (1). Hammer rap wrench handle to ensure tightness.
28. Remove body (1) from vise and reposition with diaphragm flange oriented on top.
29. Place thread sealant/lubricant onto threads of bellows (11). Insert flat-end of stem extension (10) into the center of the bellows (11); chamfered end of stem extension (10) should be protruding bellows (11). Invert bellows (11) with stem extension (10) into body (1) recess. Allow stem extension (10) to “fall” into threaded opening for bellows (11). Align threaded portion of bellows (11); rotate CW (viewed from above) the same number of engaged revolutions recorded in article 8. previous, this subsection.
30. Place diaphragm gasket (13) onto body's (1) flange aligning cutouts of gasket (13) with bolt hole openings.
31. Place diaphragm(s) (12) onto body (1) positioned concentrically. **NOTE: Reassemble pilot valve (PV) ONLY with the number of diaphragms (12) disassembled with; the 5–15 psig (0.34–1.03 Barg) spring range uses only one diaphragm (12).**
32. Concentrically position pressure plate (14) onto diaphragm(s) (12).
33. Set range spring (15) over hub of pressure plate (14).
34. Place multi-purpose, high temperature grease into recess of spring button (16) where adjusting screw (19) bears. Place spring button (16) over top-end of range spring (15) with greased recess on top side.
35. Clean threads of diaphragm bolting (17) (18). Place thread lubricant on bolts (17). Engage two sets of bolting (17) (18) for ease in rotation; disengage.
36. Place the two bolts (17) of above approximately 180° across through body (1) diaphragm flange from underneath side. Hold bolts (17) with fingers of one hand to keep from falling downwards.
37. Set spring chamber (2) down over the two protruding bolts (17), aligning the matchmarks of article 3. previous, this subsection.

38. Place the two nuts (18) onto bolts (17) of above, and finger-tighten.
39. Place remaining bolts (17) through spring chamber (2) bolt hole openings. Engage all nuts (18) onto bolts (17) along underneath side of body (1) flange and finger-tighten.
40. Remove the two upside-down bolts (17) and nuts (18) and rotate to position of other bolts (17). Place nameplate tag (21) over one of the bolts (17) before replacing into bolt hole. Finger-tighten nuts (18).
41. Observe through opening in top of spring chamber (2) to ensure the concentricity of the recess in the spring button (16) with the top opening. It may be necessary to use an awl or similar tool to realign the spring button (16) as much as possible. The spring chamber (2) is not tightened down, and may be temporarily "shifted" to help ensure alignment for the adjusting screw (19) engagement.
42. Place lubricant onto the upper exposed threads of the spring chamber's (2) adjusting screw (19) opening. Place lubricant onto the adjusting screw (19) lower-end threads. Engage adjusting screw (19) back into spring chamber (2) by rotating CW (viewed from above). Engage only until resistance is made with the range spring (15) via the spring button (16).
43. Realign the spring chamber (2) flange with the body (1) flange, and wrench-tighten bolting (17, 18) in an alternating, crossing pattern. Final tightening should be done with a torque wrench to 15 ft.-lbs. (20 N-M).

revolutions as directed in article 2. previous, this subsection.

45. Reconnect pilot valve (PV) to main valve (MV). See Figures 6, 7 and 8 for correct orientation. Pressure leak test the complete assembly per Section VII.D.

D. Main Valve (MV):

1. General Note: The actuator/topworks section of the main valve (MV) is sufficiently "heavy" for the 3" and 4" (DN80 and 100) body sizes that the procedures following are written to include overhead hoisting. Additionally, following the procedure will ensure that the internals subassembly (IS) will not "fall from within the cylinder (3)" when the cylinder (3) is oriented vertically, when gravity overcomes seal (12) friction.



WARNING

Follow procedures given herein in handling main valve topworks! Failure to heed may result in internals sliding out of cylinder and falling downwards to impact on foot!

For the 1" through 2" main valve (MV) body sizes, the actuator/topworks is not so heavy that an overhead hoist is required. However, if an overhead hoist is not used, improper handling of the removed cylinder (3) and internals subassembly (IS) can still result in the internals subassembly (IS) "falling from within the cylinder (3)" by gravity, so the above "warning statement" is still valid.



WARNING

Never replace bolting (17, 18) with just any bolting if lost. Bolt heads and nuts are marked with specification identification markings. Use only proper grades as replacements.

44. Continue CW rotation (viewed from above) of adjusting screw (19) until locknut (20) touches spring chamber (2). Back adjusting screw (19) out by rotating CCW (viewed from above) two revolutions. This position will approximate the pressure setpoint prior to disassembly if the locknut (20) is only loosened two
2. Using an overhead hoist, rig the main valve (MV). Lift and securely place the main body (1) in a vise with the cylinder head (4) directed upwards.
3. Draw or embed a match mark between the cylinder head (4), cylinder (3), bonnet (2) and body (1).
4. Loosen elongated cylinder bolting (16, 17) by rotating each nut (17) CW (viewed from above) until fully removed. Withdraw each of the four elongated bolts (16). **NOTE**: Sizes 3" and 4" (DN80 and 100) have the body's (1) bonnet flange drilled and tapped so that no bottom nut (17) is required.

16. (Cont.) recess over end of piston (12). **NOTE:** *Seal (12) should be replaced with every disassembly.*
17. Remove piston (8) and piston spring (14).
18. While holding seat ring (5) with fingers, withdraw plug-stem assembly (7). Seat ring (5) will be released from capture.
19. Remove all three of the TFE gaskets (13) and discard. These gaskets may be stuck to the cylinder head (4), cylinder (3), bonnet (2) or body (1). If any of these gaskets (13) were leaking, determine by inspection the possible reason for the leakage.
20. Remove seat ring gasket (6) from body (1) cavity and discard.
21. Using a sharp, flat-edged tool, clean the gasket facings and all surfaces where a metal-to-metal joint occurs on the body (1), bonnet (2), cylinder (3) and cylinder head (4).
22. Remove body (1) and bonnet (2) from vises and solvent clean. Solvent clean all loose parts to be reused.
23. Inspect all surfaces for wear. Replace all parts that have excessive wear. Replace seat ring (5) and plug-stem assembly (7) as a set. Hone cylinder (3) if slightly grooved.
24. Lap plug-stem assembly (7) together with seat ring (5) using a suitable lapping compound. Do for new replacement parts as well as reused parts (5, 7). Clean parts of lapping compound with suitable solvent and let dry.
25. Place cleaned body (1) back into vise.
26. Place new seat ring gasket (6) into body (1) cavity.
27. Insert the plug-stem assembly (7) through the bonnet (2) and check clearance between stem (7) and hardened bushing (18) with a wire gauge. Normal clearance is .001–.002" (.025–.050 mm). If excess clearance is due to wear in stem (7), replace plug-stem assembly (7). If clearance is due to bushing wear, place bonnet (2) under a hydraulic press and “press out” the bushing (18); “press in” a replacement bushing. If new bushing seems “loose” after pressing in, place four small tack welds along the bushing (18) OD on top of bonnet (2)-to-bushing (18) joint, taking care to not overheat the bushing (18) and distort.
28. Place bonnet (2) back into the second vise held as previous.
29. Determine correct orientation of seat ring (5) from Figure 9 herein. (DO NOT INSTALL SEAT RING (5) UPSIDE DOWN.) Insert plug-stem assembly (7) threaded end through seat ring (5) and bonnet (2) bushing (18). Push seat ring (5) into the “cage” portion of the bonnet (2).
30. Place TFE ring gasket (13) onto upper side of bonnet (2) and onto shoulder.
31. Place a thin film of lubricant onto the cylinder (3) inside wall at the wear points of the piston seal (12). Wipe excess lubricant away with a clean, dry cloth.
32. Place cylinder (3) into a strap support and lift with an overhead hoist. Swing cylinder (3) over threaded end of plug-stem assembly (7) and lower into the shoulder of bonnet (2), taking care to protect ring gasket (13) of previous article 30., above. Align match marks and apply duct tape to hold cylinder (3) to bonnet (2).
33. Place piston (8) with recess for piston spring (14) face down on flat surface.
34. Position a small section of the seal (12) circumference around the top recess of the piston (8). Apply an equal amount of thumb pressure on opposing sides of the seal (12) as the seal (12) is pressed around and over the top of the piston (8) into the recess. **NOTE:** *Install seal (12) with opening of U-Cup facing upwards.*
35. Place piston spring (14) into recess of piston (8).
36. Rotate stem (7) until the tool of previous article 13., this subsection, can be inserted through hole of stem (7). Leave the tool in the hole.
37. Carefully slide piston (8) with captured piston spring (14) into cylinder (3). Insert a rod or similar tool into the center hole of the piston (8), and simultaneously lift and move into the cylinder (3) deeper. Using fingers of one hand, push the plug-stem assembly (7) together from the plug (7) end. Lift piston (8) onto threaded portion of plug-stem assembly (7) as far as possible, removing tool when necessary. Place hand into cylinder (3) and push the piston (8) until the piston spring (14) begins to compress.

38. Place temporary eyenut onto threaded end of plug-stem assembly (7). Finger-tighten eyenut until piston spring (14) is slightly under compression.
39. Place a rope, cable, etc., through the eyenut and rig for overhead lifting. Simultaneously, loosen the grip of the vise on the bonnet (2), lift the cylinder (3) with its hoist, and lift the partial internals subassembly (IS) with its hoist. Continue the lifting slowly until the internals subassembly (IS) is vertical. Release the strap support from the cylinder (3). Fully release the vise's grip.
40. Place a round wooden peg about 2" (50 mm) tall with flat ends, and small enough to fit within the seat ring (5) onto a flat work surface. Swing partial assembly of previous article above until centered over the peg. Lower partial assembly down onto peg until weight is resting on peg. Place spacers near outside diameter of bonnet (2) 180° across to stabilize partial assembly from tipping over. See Figure 4.

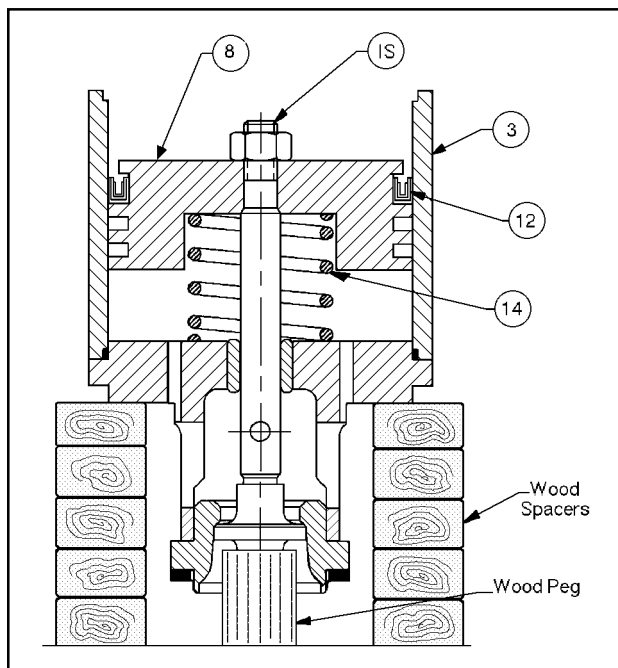

FIGURE 4
Wooden Pegs and Spacers

41. Remove overhead support from eyenut. Remove eyenut.
42. Engage stem nut (15) with stem (7) end and rotate nut (15) CW (viewed from above) about two revolutions while restraining with tool to prevent stem (7) rotation.

43. Remove the duct tape applied in previous article 32., this subsection. Grasp the cylinder (3) near its upper edge, and gently wiggle the stacked internals subassembly (IS) parts from several directions.
44. Continue to wrench-tighten stem nut (15).
45. Place duct tape 360° around the cylinder (3)-to-bonnet (2) joint.
46. Install temporary eyenut onto protruding threads of plug-stem assembly (7). Install cable, rope, etc., to overhead hoist.
47. Raise internals subassembly (IS) with cylinder (3) above wooden peg. Remove peg. Lower internals subassembly (IS) and cylinder (3) down onto the flat work surface.
48. Remove temporary eyenut.
49. Place wrench back onto stem nut (15). While grasping anti-stem rotation tool, hammer rap nut (15) tightly. Remove anti-rotation tool.
50. Place temporary eyenut back onto threaded end of plug-stem assembly (7). Re-rig to overhead hoist.
51. Lift the internals subassembly (IS) and cylinder (3). Place a suitable thread sealant in three or four places along the bottom shoulder of the bonnet (2) where the bonnet (2)-to-body (1) ring gasket (13) is located. Push the ring gasket (13) into the sealant expecting the sealant to hold the gasket (13) for final assembly and alignment; apply additional sealant if necessary.
52. Swing lifted internals subassembly (IS) and cylinder (3) over the body (1) in its vise. Align match marks and lower the internals subassembly (IS) downwards into the body (1) cavity, taking care to not damage the bonnet (2)-to-body (1) ring gasket (13). Remove overhead rigging and temporary eyenut.
53. Prepare cylinder head (4) for its ring gasket (13) similar to ring gasket (13) for bonnet (2) of previous article 33., this subsection.
54. Align match marks and lower cylinder head (4) down onto cylinder (3) upper shoulder, taking care to not damage cylinder (3)-to-cylinder head (4) ring gasket (13). Align the flat edges of the cylinder head (4) to be in the same plane as the flange of the body (1) below by rotating the head (4) as necessary.

55. Insert the four elongated cylinder bolts (16) through the bolt hole of the cylinder head (4) and downwards through the bolt hole of the body (1) flange. Install nuts (17) on the bolts (16) by rotating nuts (17) CCW (viewed from above). Finger tighten all nuts (17).

WARNING

Never replace bolting (17, 18) with just any bolting if lost. Bolt heads and nuts are marked with specification identification markings. Use only proper grades as replacements.

56. Using a torque wrench, tighten the bolting (16, 17) to the levels indicated in the following table in an alternating, crossing pattern in 1/4 revolution increments.

| Main Valve Body Size | Torque | |
|-------------------------|---------|-----------|
| | ft-lbs | (N-M) |
| 1" (DN25) | 25–30 | (33–40) |
| 1-1/2" (DN40) | 25–30 | (33–40) |
| 2" (DN50) | 70–75 | (94–101) |
| 3" (DN80) | 100–110 | (135–149) |
| 4" (DN100) | 150–160 | (203–216) |

57. Rig the reassembled main valve (MV) for overhead hoisting. Remove temporary duct tape. Lift and remove from vise.

E. Joining:

1. Place main valve body (1) into vise, oriented to allow correct positioning of pilot valve (PV) and interconnecting piping. See Figures 6, 7 & 8.
2. Place thread sealant on threaded ends of pipe nipples (19, 29 and 30) and on street elbow (27). Ensure that excess material is removed and not allowed to enter the regulator upon start-up.
3. Reconnect pilot valve (PV) to main valve (MV) using appropriate pipe nipple(s) and fittings (19, 26, 27, 28, 29 & 30). Using a pipe wrench, ensure that all connections are tight and in proper orientation.
4. Reinstall interconnecting tubing (21) between main valve (MV) cylinder head (4) and pilot valve (PV) body (1).
5. Leak test the combined unit per Section VII.D.

SECTION VII

VII. LEAK TESTING

A. General:

1. A POSR-2 is a metal-to-metal seated design with standard hardened trim in main valve (MV) and pilot valve (PV).
2. Both pilot valve (PV) and main valve (MV) are of a flow-to-close design, and can be seat leakage tested without extensive setup.
3. There are two design pressures for a POSR-2; one for the higher inlet pressure zone, and another for the lower outlet pressure zone.

Recommended Test Pressures –

- Inlet: 100 psig (7.0 Barg).
Outlet: 15 psig (1.03 Barg) for Pilot with 5–15 psig (0.34–1.03 Barg) spring range.
Outlet: 40 psig (2.7 Barg) for Pilots with (Cont.) 15–150 psig (1.03–10.3 Barg) spring ranges.

B. Seat Leakage – Pilot Valve (PV):

1. Separate pilot valve (PV) from main valve (MV), see Section VI, subsection B.
2. Install a temporary 1/4" - NPT pipe plug into the (P_{Int}) connection.
3. Install a hose fitting and hose into the 1/2" FNPT connection port of the pilot valve (PV) body (1). Place other “open” end of the hose at the bottom of a glass container having approximately 1/8" (3 mm) of water depth. **NOTE:** Pilot valve (PV) and glass container should be at about the same elevation.
4. Relax the range spring (15) by rotating the adjusting screw (19) CCW (viewed from above adjusting screw) until fully loose. Keep track of the number of revolutions in the box below:

No. of Revolutions adjusting screw rotated:

- Connect temporary air supply with in-line adjustable airset regulator to P₂ outlet of pilot. Slowly pressurize the pilot valve (PV) while observing the jar with water. Bring pressure to 50 psig (3.4 Barg). Wait a minimum of five minutes. Observe for leakage of bubbles in the water jar. If the number of bubbles is greater than one (1) per minute, the leakage is at the point where trim replacement is recommended. (Recommend pressure integrity test per subsection D. herein.)
- Remove leak test apparatus. Reconnect pilot valve (PV) to main valve (MV) using appropriate pipe nipples, tubing and fittings (19, 20, 26, 27, 28, 29 & 30). Ensure all connections are tight and in proper orientation.

- Remove hose from open end of jar. Open valve #2. Close valve #1. Place hose end back into jar. Follow a similar procedure as in article 4. previous, to leak test the Cylinder (3)-to-Seal Ring (12) seal. (If a new seal ring (12) was installed, stroke the piston (8) about 50 cycles by alternately opening/closing valves #2 and #3 in sequence, attempting to “seat” the seal ring (12) before beginning the leak test.) (Recommend pressure integrity test per subsection D. herein.)
- Remove leak test apparatus. Reconnect pilot valve (PV) to main valve (MV) using appropriate pipe nipples, tubing and fittings (19, 20, 26, 27, 28, 29 & 30). Ensure all connections are tight and in proper orientation.

C. Seat Leakage – Main Valve (MV):

NOTE: The main valve's (MV) plug (7)-to-seat (5) leakage and cylinder (3)-to-seal ring (12) leakage should both be tested.

- Separate pilot valve (PV) from main valve (MV). See Section VI, subsection B.
- Insert tapped pipe plugs with hose fittings into both the inlet and outlet connections. Place open end of outlet hose in jar of water per B.3. above.
- Install temporary hoses with tight shutoff instrument needle valves at three connections; cylinder head-inlet, vent, and inlet of main valve. See Figure 5.
- Close valves #2, and #3. Open valve #1. Slowly pressurize the inlet up to 50 psig (3.4 Barg). Wait a minimum of 10 minutes. Observe for leakage of bubbles in the water jar. If the number of bubbles is greater than the limit indicated below in Table 1, trim replacement or extra lapping is recommended.

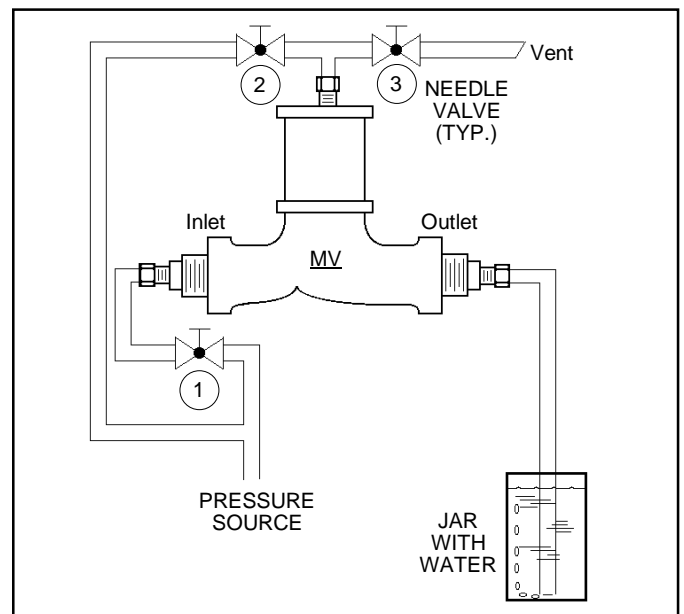

FIGURE 5:

D. Pressure Integrity Leak Test:

- Test pilot valve (PV) and main valve (MV) assembled together with all interconnecting pipe (19), tubing (21) and fittings (20).
- Insert tapped pipe plugs with hose fittings to both inlet and outlet body (1) connections.
- Install temporary hoses with tight shutoff instrument needle valves at outlet connection of main valve (MV) and of the pilot valve (PV).
- Connect temporary air supply with in-line adjustable airset regulator to inlet connection of main valve (MV).

TABLE 1

| Body Size in. (mm) | Maximum Leak Rate | |
|-----------------------|---------------------------|---|
| | Plug-to-Seat Ring SCFH | Cylinder-to-Seal Ring Bubbles Per Minute |
| 1" DN25 | 2 | <1 |
| 1-1/2" DN40 | 4 | <1 |
| 2" DN50 | 7 | 1 |
| 3" DN80 | 13 | 1-3 |
| 4" DN100 | 17 | 3-6 |

5. Close needle valve at outlet connection of main valve (MV). Crack open the needle valve at the pilot valve (PV) outlet.
6. Rotate adjusting screw (19) of pilot valve (PV) CW (viewed from above adjusting screw) until a point of high resistance occurs; this should correspond to the diaphragm (12) pushing against the body's (1) down travel stops. Record the number of revolutions the adjusting screw was rotated in the box below:

| |
|--|
| No. of revolutions the adjusting screw was rotated _____ |
|--|

7. Slowly pressurize the inlet of the main valve (MV) and pilot valve (PV) to 100 psig (6.9 Barg).
- NOTE:** If the pilot valve (PV) has any other range spring (15) above 5–15 psig (.34–1.03 Barg), the test pressure can be raised to 200 psig (13.8 Barg).

8. Using a solution of leak detection fluid and water, apply a liberal amount of the solution to cover each external joint, including the threaded fittings (20), tubing (21) and the interconnecting pipe nipple (19) threaded connections. Wait a minimum of five minutes to allow sufficient time for a leak to form bubbles. Repeat this procedure with a second five minute wait.
9. Identify and mark any observed leakage. Disassemble down to the point of leakage and determine the cause of the leak. Repair and reassemble per instructions in Section VI. Retest per Section VII.
10. Shut off pressure to inlet connection of main valve (MV) and remove all leak testing equipment. Reset the adjusting screw (19) back to its normal setpoint by rotating the screw (19) CCW (viewed from above) the same number of revolutions recorded in Article 6. previous, this subsection.

SECTION VIII

VIII. TROUBLE SHOOTING GUIDE

1. Erratic or Noisy Operation.

| Possible Cause | Remedy |
|---|---|
| a. Wet steam or condensate at the inlet. | a. Install a steam trap on the inlet side of the regulator. |
| b. Clogged pilot valve screen. | b. Clean or replace. Blowdown inlet drip leg. Install upstream strainer, if severe. |
| c. Regulator oversized for flow conditions. | c. Install correct size. |
| d. Insufficiently sloped line. | d. Move tap from top of pipe to side; or, increase sensing tube to 3/8" OD. |

2. Regulator won't maintain downstream set pressure.

| Possible Cause | Remedy |
|---|---|
| a. Valve undersized. | a. Resize based on actual service conditions. |
| b. Incorrect range spring. | b. Replace range spring. |
| c. Failed bellows. | c. Replace bellows assembly. |
| d. Failed piston seal ring. | d. Replace seal ring. |
| e. Pressure drop less than required 15 or 20 psid (1–1.4 Bard). | e. Contact your Cashco Representative. |
| f. Insufficiently sloped line. | f. Move tap from top of pipe to side; or, increase sensing tube to 3/8" OD. |

3. Leakage through the pilot spring chamber vent hole.

| Possible Cause | Remedy |
|-------------------------|-----------------------|
| a. Defective diaphragm. | a. Replace diaphragm. |

4. Excessive pressure downstream.

| Possible Cause | Remedy |
|--|--|
| a. Main valve or pilot plug not closing. | a. Inspect the seating of the main valve and then the pilot plug seating. Clean or replace. Check seat gaskets; replace. |

SECTION IX

IX. PARTS ORDERING INFORMATION

CAUTION

The Model POSR-2 has recently undergone major redesign work with respect to several component parts inside the main body. Recommended Spare Parts are affected. These New Style parts / kits are not interchangeable in old regulators. Carefully select replacement parts utilizing the following parameters.

A. For Old Design POSR-2: Two purchase/rework options are available for a limited time:

1. Purchase a Conversion Kit to upgrade old unit to new design, reference Table "B". (Includes Cylinder, Piston, Plug & Stem assembly, Seat Ring plus Gaskets and Seals.)
2. Purchase a new design main valve (New-MV) from Table "A". (*NOTE: Limited to CI body material only.*)

To confirm if regulator is old design or new, obtain Serial Number from unit's SST name plate and contact the factory. Factory will specify required parts/kits and cost.

B. For New Design POSR-2: There are two methods, A and B, to obtain parts ordering information/numbers. These methods are listed below in order of ease of entering. The least expensive method is to utilize parts in kits where possible.

METHOD A – USE OF BILL OF MATERIAL:

- Step 1. If available, obtain the 18-character product code number from the Bill of Material Sheet.

(Confirm that it duplicates the 18 digit product code stamped on the regulator's SST name plate.

□□□ – □□□ 7 – □□□□□□□□□□

***NOTE:** If there isn't a product code stamped on the SST name plate, obtain the serial number and contact the factory. Unit is of old design. See A. previous.*

- Step 2. Identify which kits or parts are desired from the BOM sheet – reference the cross-sectional drawing and the following PART KIT Table "C".

- Step 3. Contact you local Cashco, Inc., Sales Representative and specify the product code numbers, appropriate kit code number(s) along with any part numbers not included in the desired kit(s). Costs for required kits and parts can be given by the Sales Representative.

METHOD B – USE OF REGULATOR'S SST NAME PLATE:

- Step 1. Obtain all available information from metal tag.
 - a. 18-Character product code.
 - b. Serial number.
 - c. Body size/end connections.
 - d. Body material.
- Step 2. With the information from Step 1, contact your local Cashco, Inc., Sales Representative who will confirm with the factory to determine the original internal construction.
- Step 3. Factory will relay information to the Sales Representative who will advise you with correct part/kit numbers and prices.

**TABLE A
POSR-2 MAIN VALVE UNITS**

| Size | Material | End Connection | Part Number |
|--------|----------|----------------|-------------------|
| 1" | CI | NPT | A66-25-A-S5101-00 |
| 1-1/2" | CI | NPT | A66-25-A-S5151-00 |
| 2" | CI | NPT | A66-25-A-S5200-02 |

**TABLE B
MAIN VALVE CONVERSION KITS
(Old Design-to-New Design)**

| Size | Material | End Connection | Kit Numbers |
|--------|----------|----------------|--------------------|
| 1" | All | All | A99-E6-K-S5101-00A |
| 1-1/2" | All | All | A99-E6-K-S5151-00A |
| 2" | All | All | A99-E6-K-S5201-00A |
| 3" | All | All | A99-E6-K-S5301-00A |
| 4" | All | All | A99-E6-K-S5401-00A |

**TABLE C
MODEL POSR-2
REDESIGNED MAIN VALVE
PARTS KIT NUMBERS
(Kit Numbers Shaded)**

| Trim Design No. | Kit Abbreviation | Size | | | | |
|-----------------|------------------|------------|------------|------------|------------|------------|
| | | 1" | 1-1/2" | 2" | 3" | 4" |
| S2 | A | WB1-AS2K-B | WBG-AS2K-B | WB2-AS2K-B | WB3-AS2K-B | WB4-AS2K-B |
| | B | WB1-BS2K-B | WBG-BS2K-B | WB2-BS2K-B | WB3-BS2K-B | WB4-BS2K-B |

**TABLE D
POSR-2 PILOT VALVE
PART KIT NUMBERS**

| | |
|-------|--------------------|
| Kit A | A99-P2-K-PILOT-0AA |
| Kit B | A99-P2-K-PILOT-0BA |

**POSR-2 "PILOT"
* COLOR-CODED SPRING CHART
(Steel Plated Springs)**

| Range Spring psig | All Sizes Part No./Spring Color |
|----------------------|------------------------------------|
| 5-15 | 830-69-5-00101-95 Red |
| 10-40 | 830-69-5-00103-95 Blue |
| 30-80 | 830-69-5-01160-95 Dark Green |
| 70-150 | 830-H2-5-01180-95 White |

**NOTE: If it becomes necessary to change a regulator's range spring and install a new spring for a different pressure range, A NEW CASHCO, INC., NAMEPLATE MUST BE AFFIXED TO THE REGULATOR. Contact your local Cashco, Inc., Sales Representative and specify the new pressure range and the serial number off the existing name plate. They will contact the factory who will review unit's original internal construction and determine new operating pressure limits. Await the Sales Representative's return contact with the proper part numbers and cost.*

NOTES

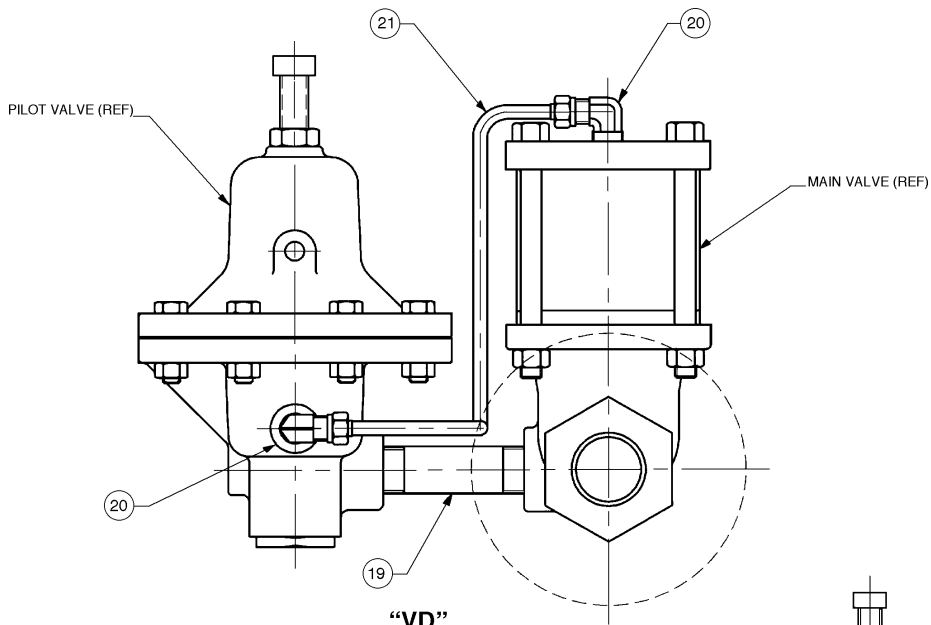

“VD”
FIGURE 6

ITEM NO. DESCRIPTION

- 19 Pipe Nipple
- 20 Tube Fitting
- 21 Tubing
- 26 90° Elbow
- 27 90° Street Elbow
- 28 Union
- 29 Pipe Nipple
- 30 Pipe Nipple

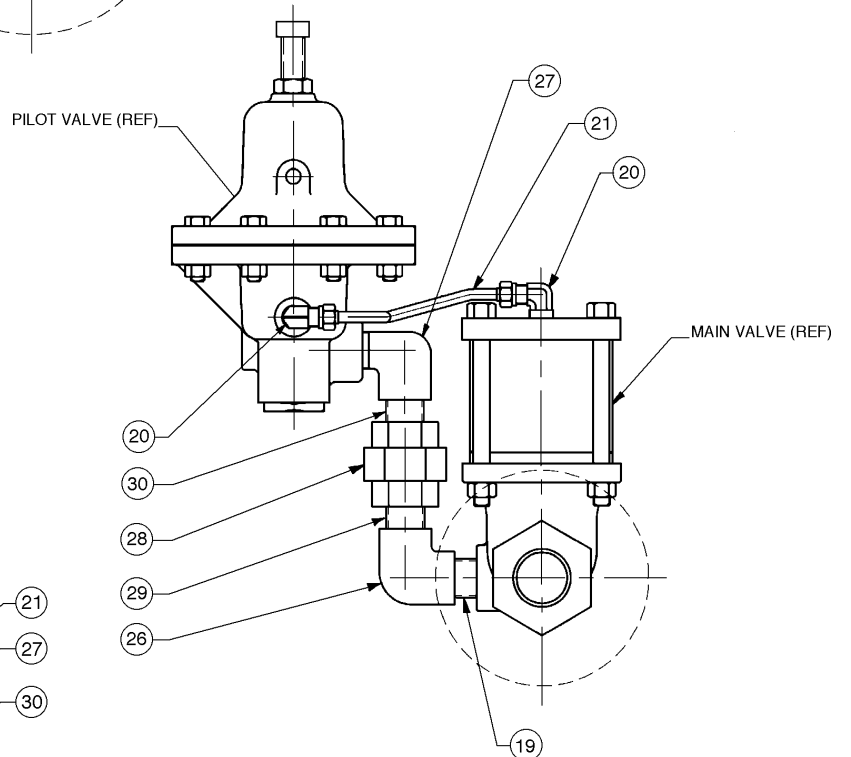

“H”
FIGURE 7

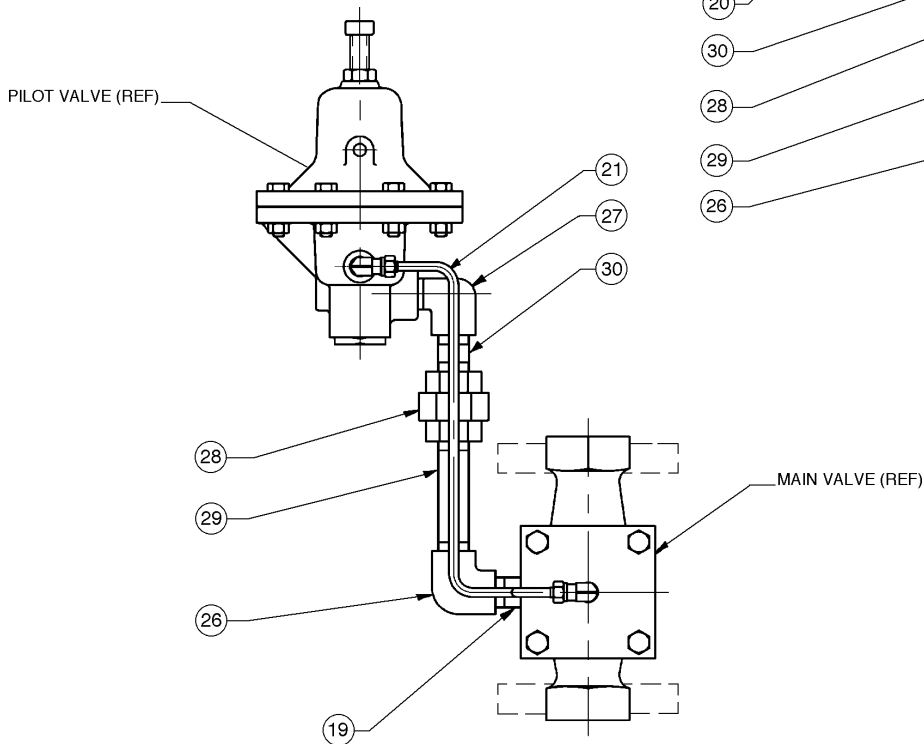

“VU”
FIGURE 8

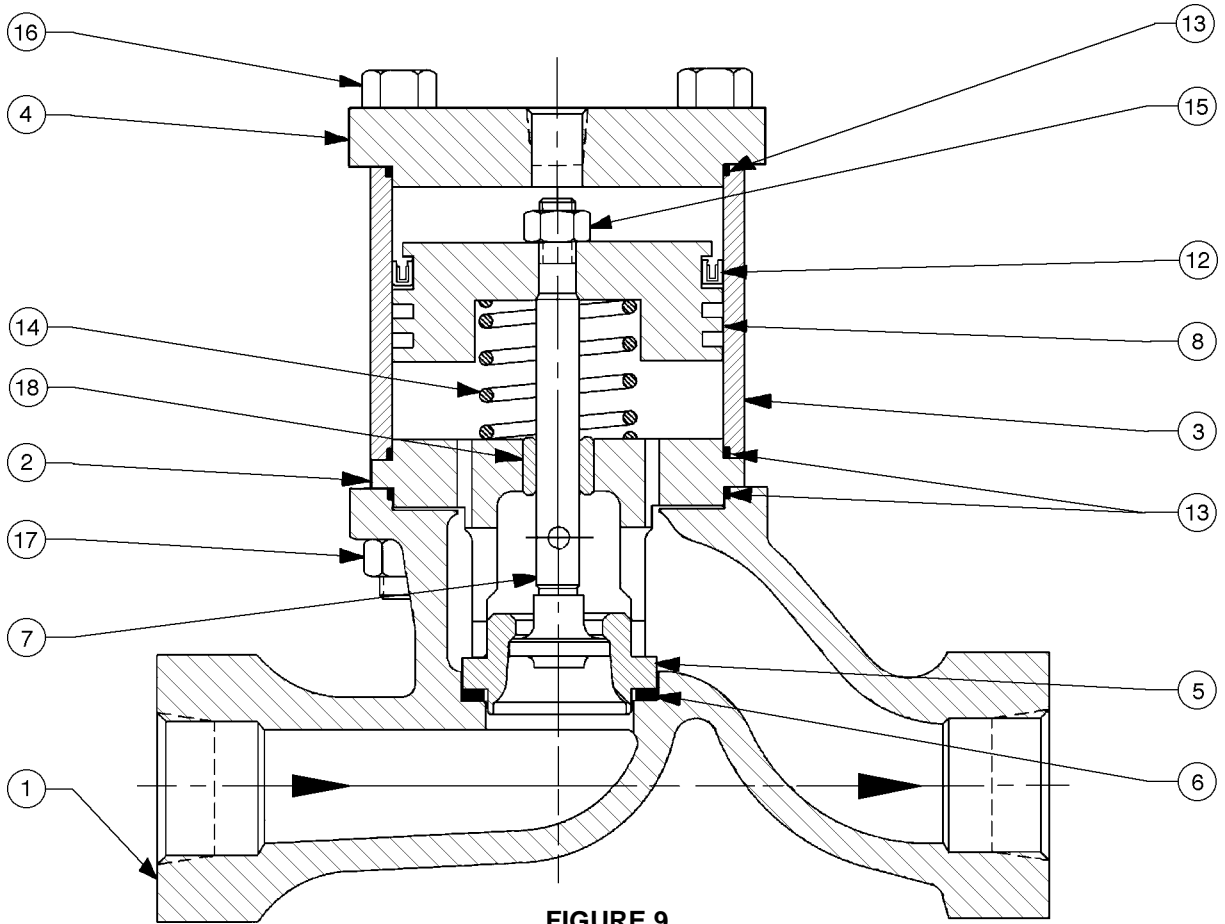

**FIGURE 9
MV – MAIN VALVE**

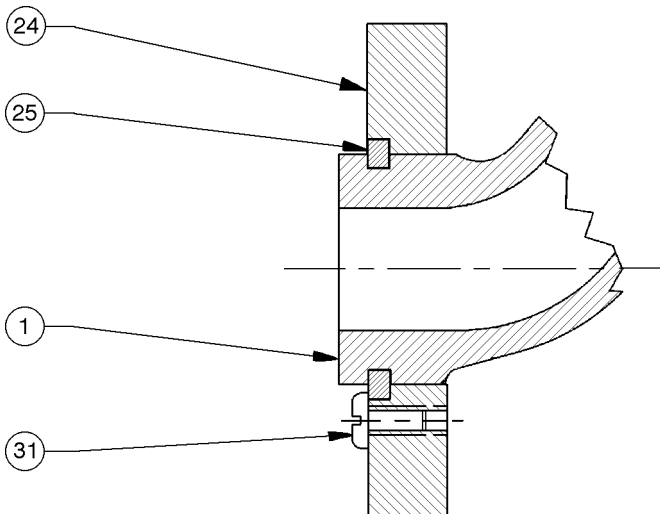
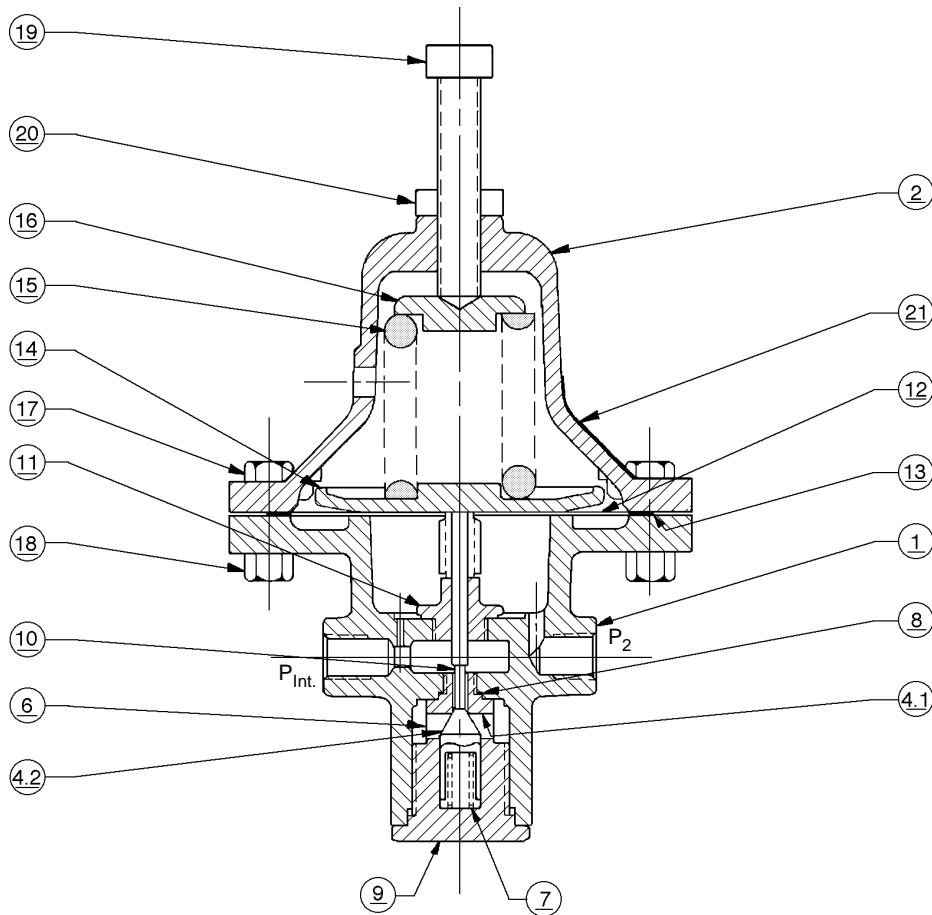

**FIGURE 10
POSR-2 Flanged End Connection**

| ITEM NO. | DESCRIPTION |
|----------|--------------------------|
| 1 | Body |
| 2 | Bonnet |
| 3 | Cylinder |
| 4 | Cylinder Head |
| 5 | Seat Ring |
| 6 | Seat Ring Gasket |
| 7 | Valve Plug & Stem Assy. |
| 8 | Piston |
| 12 | Seal |
| 13 | Bonnet & Cylinder Gasket |
| 14 | Piston Spring |
| 15 | Hex. Nut |
| 16 | Hex. Head Bolt |
| 17 | Hex. Nut |
| 18 | Bushing |
| 24 | Flange |
| 25 | Flange Split Ring |
| 31 | Machine Screw |

Not Shown on Drawing

| | |
|----|-------------|
| 22 | Nameplate |
| 23 | Drive Screw |
| 43 | Drive Screw |
| 44 | Flow-Arrow |



**FIGURE 11
PV – PILOT VALVE**

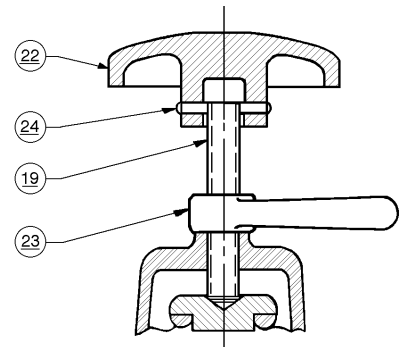

**FIGURE 12
HANDWHEEL &
LOCKING LEVER**

| <u>ITEM NO.</u> | <u>DESCRIPTION</u> | <u>ITEM NO.</u> | <u>DESCRIPTION</u> |
|-----------------|----------------------|-----------------|--------------------------|
| <u>1</u> | Body | <u>13</u> | Diaphragm Gasket |
| <u>2</u> | Spring Chamber | <u>14</u> | Pressure Plate |
| <u>4</u> | Plug & Seat Assembly | <u>15</u> | Range Spring |
| <u>4.1</u> | Valve Seat | <u>16</u> | Spring Button |
| <u>4.2</u> | Valve Plug | <u>17</u> | Cap Screw |
| <u>6</u> | Screen | <u>18</u> | Hex. Nut |
| <u>7</u> | Spring | <u>19</u> | Adjusting Screw |
| <u>8</u> | Valve Seat Gasket | <u>20</u> | Adjusting Screw Lock Nut |
| <u>9</u> | Body Cap | <u>21</u> | Nameplate |
| <u>10</u> | Stem | <u>22</u> | Handwheel |
| <u>11</u> | Bellows Subassembly | <u>23</u> | Locking Lever |
| <u>12</u> | Diaphragm | <u>24</u> | Spring Pin |

IOM-MODEL "POSR-2"-ADDENDUM

- Applies to the following IOM:** IOM-POSR-2, 07-93 - Model POSR-2, Pilot Operated Pressure Reducing Regulator
- Subject of Addendum:** To modify Maintenance Instructions for Main Valve concerning new (1) piece piston (8)
- Replaces:** Disregard maintenance instructions concerning retainer (11) in Section VI.D, Articles 15, 16, 17 & 43 as retainer is now machined integral to piston (8). Use following text to remove and replace piston seal (12). Also note changes in drawings for Figure 3 and Figure 6.

19 a. **Seal Removal:** Using a needle-nose pliers, grasp outside lip of seal (12), lift the seal (12) up, and pull out of recess over end of piston (8). **NOTE:** Seal (12) should always be replaced with every disassembly.

35 a. **Seal Replacement:** Place piston (8) with recess for piston spring (14) face down on flat surface.

b. Position a small portion of the seal (12) circumference in the top recess of the piston (8). Apply an equal amount of thumb pressure on opposing sides of the seal (12) as the seal (12) is pressed around and over the top of the piston (8) and into the recess. **NOTE:** Install seal (12) with open U-Cup facing upwards.

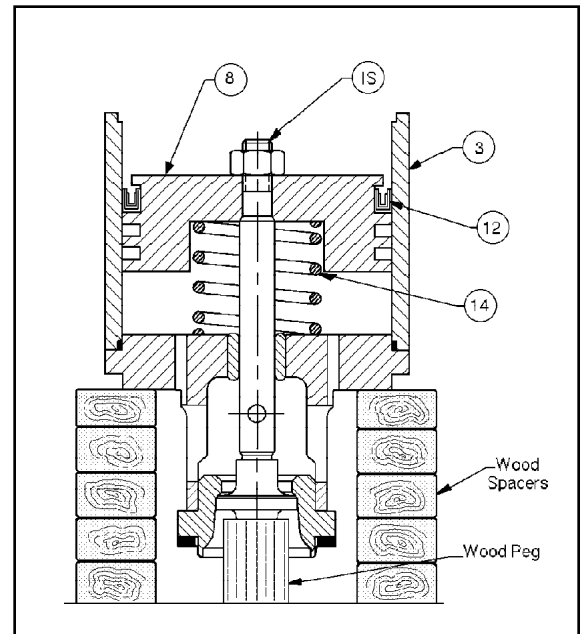

FIGURE 4
Wooden Pegs and Spacers

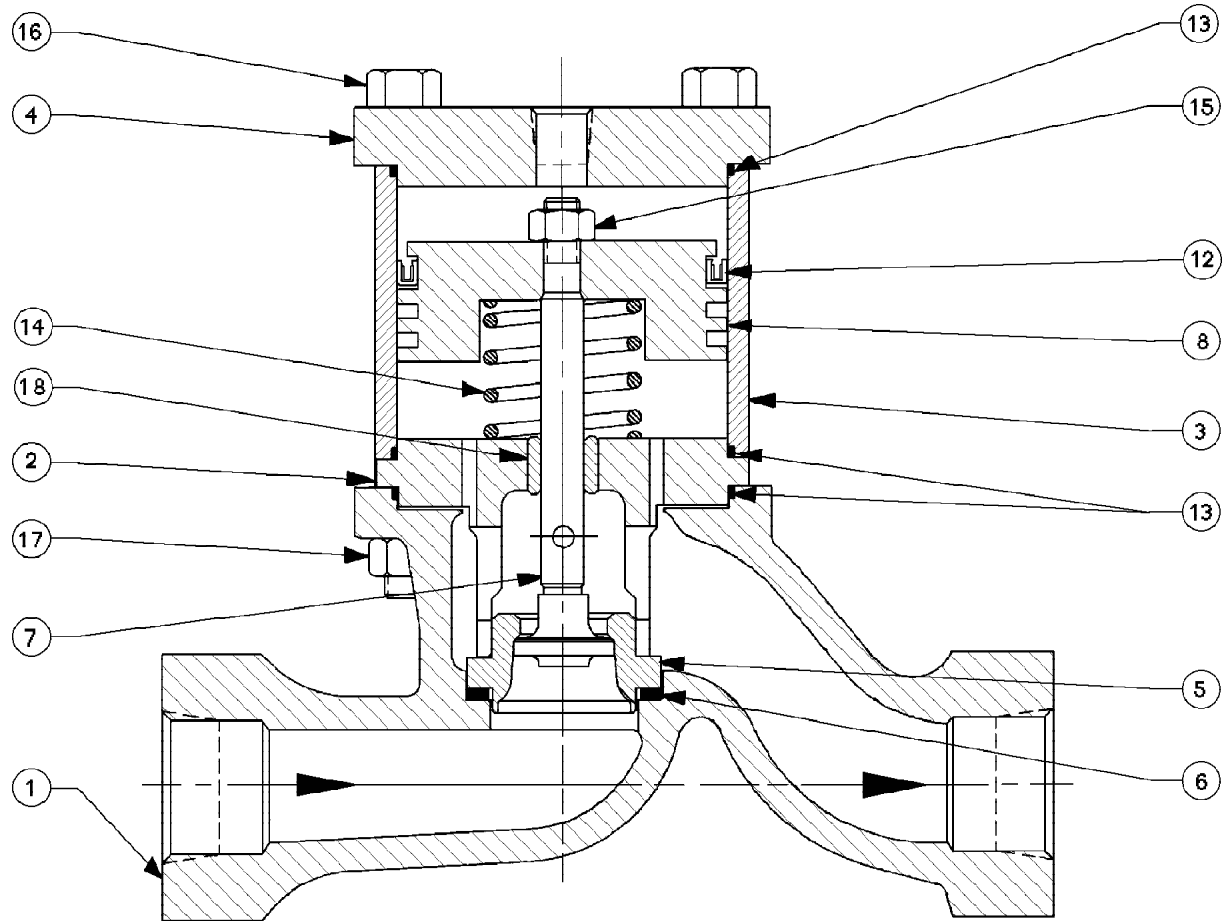

FIGURE 6
MV – MAIN VALVE

| <u>ITEM NO.</u> | <u>DESCRIPTION</u> |
|-----------------|--------------------------|
| 1 | Body |
| 2 | Bonnet |
| 3 | Cylinder |
| 4 | Cylinder Head |
| 5 | Seat Ring |
| 6 | Seat Ring Gasket |
| 7 | Valve Plug & Stem Assy. |
| 8 | Piston |
| 12 | Seal |
| 13 | Bonnet & Cylinder Gasket |
| 14 | Piston Spring |
| 15 | Hex. Nut |
| 16 | Hex. Head Bolt |
| 17 | Hex. Nut |
| 18 | Bushing |