



MODEL 1465

PRESSURE REDUCING REGULATOR

SECTION I

I. DESCRIPTION AND SCOPE

The Model 1465 is a high pressure reducing regulator designed primarily for analytical sampling and low flow applications. Size is 1/4" (DN8). With proper trim utilization, the unit is suitable for liquid and gaseous service. Refer to Technical Bulletin 1465-TB for design conditions and selection recommendations. **NOT FOR DEAD END SERVICE.**

SECTION II

II. INSTALLATION



WARNING

Do not dead end (no flow demand) downstream of the regulator. The inlet pressure will transmit by the metal seat (not positive shut-off) and equalize on the downstream. This will lead to diaphragm failure, regulator malfunction, and possible damage to system instrumentation downstream.

1. An inlet block valve should always be installed.
2. If service application is continuous such that shut-down is not readily accomplished, it is recommended that an inlet block valve, outlet block valve, and a manual bypass valve be installed.
3. Pipe unions should be installed to allow removal from piping.
4. An outlet pressure gauge should be located approximately ten pipe diameters downstream, and within sight.
5. All installations should include a downstream relief device if the inlet pressure could exceed the pressure rating of any downstream equipment or the maximum outlet pressure rating of the unit.



CAUTION

DO NOT HYDROSTATIC TEST THRU AN INSTALLED UNIT; ISOLATE REGULATOR FROM TEST. The upper range spring pressure level listed on the nameplate is the recommended "upper operative limit" for the sensing diaphragm (see Section IV. Startup, Number 7). Higher pressures could cause internal damage. In addition, note on the nameplate that the Inlet and Outlet pressure and temperature ratings are at different levels.

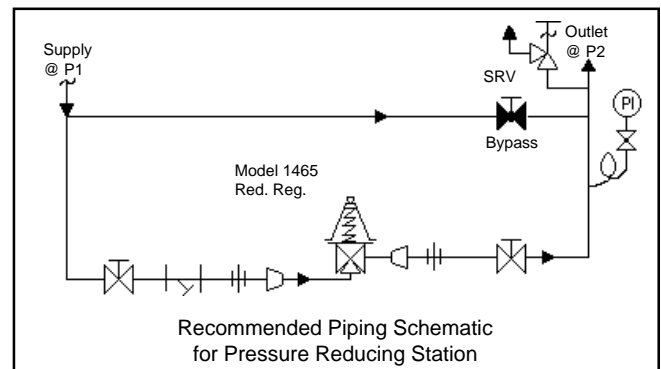

6. Clean the piping of all foreign material including chips, welding scale, oil, grease and dirt before installing the regulator. Strainers are recommended.
7. In placing thread sealant on pipe ends prior to engagement, ensure that excess material is removed and not allowed to enter the regulator upon startup.
8. Flow Direction: Install in accordance with the flow direction arrow cast on the body. The inlet pressure is connected to the bottom connection and the outlet (reduced) pressure is connected to the side connection. When installing, hold by the body (1) hex to keep the regulator firm.
9. Basic Regulator - (Refer to Figure 1): Regulator may be installed in any position in relation to the pipe. Recommended position is with spring chamber vertical upwards. Orient such that the spring chamber vent hole does not collect rainwater or debris.
10. Regulators are not to be direct buried underground.
11. For insulated piping systems, recommendation is to not insulate the regulator.

SECTION III

III. PRINCIPLE OF OPERATION

1. Movement occurs when the inlet pressure passes by the seat causing a distributive force on the underside of the diaphragm. This, in turn, opposes the point force of the range spring causing upward movement of the diaphragm, allowing the

plug to seat. When set pressure decreases, due to demand, the distributive force beneath the diaphragm lessens - allowing the range spring to open the seat and regulate pressure.

2. A complete diaphragm failure will cause the regulator to fail open.

SECTION IV

IV. START-UP

1. Start with the block valves closed. A bypass valve may be used to maintain outlet pressure in the downstream system without changing the following steps.
2. Relax the range spring (10) by turning the adjusting screw (12) counter clockwise (CCW) a minimum of three (3) full revolutions. This reduces the outlet (downstream) pressure setpoint. **NOTE:** *If the Option -2 or -22 is utilized, the adjusting screw (12) and locknut (13) are replaced with a knob (18) and locknut (13). With Option -2 +80 or -22 +80, the adjusting screw (12) and locknut (13) are replaced with a handwheel subassembly (20) and locknut (13).*
3. If it is a "hot" piping system, and equipped with a bypass valve, slowly open the bypass valve to preheat the system piping and to allow slow expansion of the piping. Ensure proper steam trap operation if installed. Closely monitor outlet (downstream) pressure via gauge to ensure not over-pressurizing. **NOTE:** *If no bypass valve is installed, extra caution should be used in starting up a cold system; i.e. do everything slowly.*
4. Crack open the outlet (downstream) block valve.
5. Slowly open the inlet (upstream) block valve observing the outlet (downstream) pressure gauge.

Determine if the regulator is flowing. If not, slowly rotate the regulator adjusting screw (12) clockwise (CW) until flow begins.

6. Continue to slowly open the inlet (upstream) block valve until fully open.
7. Continue to slowly open the outlet (downstream) block valve, especially when the downstream piping system isn't pressurized. If the outlet (downstream) pressure exceeds the desired pressure, close the block valve and go to Step 2, then return to Step 4.
8. When flow is established steady enough that the outlet (downstream) block valve is fully open, begin to slowly close the bypass valve if installed.
9. Develop system flow to a level near its expected normal rate, and reset the regulator setpoint by turning the adjusting screw (12) CW to increase outlet pressure or CCW to reduce outlet pressure.
10. Reduce system flow to a minimum level and observe setpoint. Outlet pressure will rise from the setpoint of Step 9. The maximum rise in outlet pressure on decreasing flow should not exceed the stated upper limit of the range spring by greater than 10%; i.e. 5-30 psig (.34-2.07 Barg) range spring, at low flow the outlet pressure should not exceed 33 psig (2.28 Barg). If it does, consult factory.

SECTION V

V. SHUTDOWN

1. On systems with a bypass valve, and where system pressure is to be maintained as the regulator is shut down, slowly open the bypass valve while closing the inlet (upstream) block valve. Fully close the inlet (upstream) block valve. (When on bypass, the system pressure must be constantly observed and manually regulated.) Close the outlet (downstream) block valve.



2. If the regulator and system are to both be shut down, slowly close the inlet (upstream) block valve. Close the outlet (downstream) valve only if regulator removal is required.

SECTION VI

VI. MAINTENANCE



WARNING

SYSTEM UNDER PRESSURE. Prior to performing any maintenance, isolate the regulator from the system and relieve all pressure. Failure to do so could result in personal injury.

A. General:

1. Maintenance procedures hereinafter are based upon removal of the regulator from the pipeline where installed.
2. Owner should refer to owner's procedures for removal, handling, cleaning and disposal of non-resuable parts, i.e. O-rings, etc.
3. Refer to Figure 1 for the standard regulator and its options.

B. Diaphragm Replacement:

1. Securely install the body (1) in a vise with the spring chamber (2) directed upwards.



WARNING

SPRING UNDER COMPRESSION. Prior to removing spring chamber, relieve spring compression by backing out the adjusting screw or handwheel. Failure to do so may result in flying parts that could cause personal injury.

2. Relax range spring (10) by turning adjusting screw (12) CCW until removed from spring chamber (2). **NOTE:** If the Option -2 or -22 is utilized, the adjusting screw (12) and locknut (13) are replaced with a knob (18) and locknut (13). With the Option -2 +80 or -22 + 80, the adjusting screw (12) and locknut (13) are replaced with a handwheel subassembly (20) and locknut (13).
3. Loosen spring chamber (2) by placing wrench on "flats" and rotating CCW making sure **not** to use the flats on either side of the vent hole.
4. Remove spring chamber (2), spring button (11), and range spring (10). **NOTE:** For units with Option -80 (spring ranges 270-400 psig (18.6-27.6 Barg) and 360-500 psig (24.8 - 34.5 Barg)) also remove the thrust bearing (15), upper bearing washer (16), and lower bearing washer (17). Inspect threads of spring chamber (2) for cleanliness.

5. Remove pressure plate (9) and inspect to ensure no deformation due to over-pressurization. If deformed, replace.
6. Remove diaphragm(s) (8), O-ring (7) and pusher plate (6). Inspect pusher plate (6) to ensure no deformation due to over-pressurization. If deformed, replace. Discard O-ring (7) and diaphragm(s) (8).
7. Clean body (1) and body recess. **NOTE:** On regulators originally supplied as "oxygen clean", Option 1465-55, maintenance must include a level of cleanliness equal to Cashco's cleaning Standard #S-1134. Contact factory for details.
8. Install new O-ring (7) and diaphragm(s) (8). **NOTE:** Refer to the quantity of diaphragm(s) (8) incorporated in the bill of materials listing. Depending on outlet pressure level, multiple metal diaphragms may be "stacked".
9. Visually center pressure plate (9) on diaphragm(s) (8). Place the range spring (10) on to the retainer hub of the pressure plate (9).
10. Place multi-purpose, high temperature grease into the depression of the spring button (11) where adjusting screw (12) bears. Set spring button (11) onto range spring (10); ensure spring button (11) is laying flat. **NOTE:** For units with Option -80 (spring ranges 270-400 psig (18.6-27.6 Barg) and 360-500 psig (24.8-34.5 Barg)) position spring button (11), thrust bearing (15), upper bearing washer (16), and lower bearing washer (17) on top of the range spring (10).
11. Apply appropriate lubricant to threads of spring chamber (2), and reverse Steps B.2 and B.3 to complete assembly. Tighten spring chamber (2) to body (1) with 30-35 ft-lbs torque.
12. Pressurize with air and soap solution test around body (1) and spring chamber (2) for leakage. Ensure that an outlet pressure is maintained during this leak test of at least mid-range spring level; i.e. 125-200 psig (8.6-13.8 Barg) range spring, 163 psig (11.2 Barg) test pressure minimum.

C. Trim Inspection:

1. Trim inspection requires that the diaphragm(s) be removed. Refer to previous procedure Section VI.B, steps 1 through 7.
2. Remove body (1) from vise and secure a screwdriver, tool end up, in vise. Set body (1)

so as to engage screwdriver into slotted end of the plug (3) from the body (1) inlet connection and hold firm.

3. Remove pusher plate (6). Looking down into the body (1) cavity, use a slotted tool to push down on the spring seat (5) and slip sideways to disengage (through slot) from plug (3).
4. Remove spring seat (5) and plug spring (4).
5. Grasp plug (3) while carefully lifting body (1). Remove plug (3) from body (1) inlet, taking care not to allow plug (3) to drop out.
6. Inspect integral seat in body (1). If seat shows erosion or wear, replace regulator.
7. Clean debris from within body (1) cavity. Clean parts to be reused. **NOTE:** *On regulators originally supplied as "oxygen clean", Option 1465-55 maintenance must include a level of cleanliness equal to Cashco's cleaning spec. #S-1134. Contact factory for details.*
8. Inspect spring seat (5), plug spring (4) and plug (3). If worn, nicked or depressed, replace regulator.
9. Lap plug (3) with lapping compound by inserting it back up into the body (1) inlet and hold firm. Engage a screwdriver into the slotted end of the plug (3) from the body (1) inlet and rotate plug (1) back and forth in a circular motion. Do not overlap.
10. Reverse steps 1 through 5 for reassembly. **NOTE:** *When reassembling plug (3), plug spring (4), and spring seat (5), be sure that this "assembly" is centered into the body (1) cavity to ensure proper seating of plug (3). Tighten spring chamber (2) to body (1) with 30-35 ft-lbs torque.*
11. Bench test unit for suitable operation. **NOTE:** *Regulators are not tight shut off devices. Even if pressure builds up beyond setpoint, a regulator may or may not develop bubble tight shut off.*
12. Pressurize with air and soap solution test around body (1) and spring chamber (2) for leakage. Ensure that an outlet pressure is maintained during this leak test of at least mid-range spring level; i.e. 125-200 psig (8.6-13.8 Barg) range spring, 163 psig (11.2 Barg) test pressure minimum.

SECTION VII

VII. TROUBLE SHOOTING GUIDE

1. Erratic operation; chattering.

Possible Causes	Remedies
A. Oversized regulator; inadequate rangeability.	A1. Check actual flow conditions, re-size regulator for minimum and maximum flow. A2. Increase flow rate. A3. Decrease regulator pressure drop; decrease inlet pressure by placing a throttling orifice in inlet piping union. A4. Install next step higher range spring. A5. Before replacing regulator, contact factory.
B. Cavitation	B. Use multiple 1465's in series to stage the pressure drops. Refer to 1465 Technical Bulletin for water cavitation chart.

2. Leakage through the spring chamber vent hole.

Possible Causes	Remedies
A. Normal-life diaphragm failure.	A. Replace diaphragm.
B. Abnormal short-life diaphragm failure.	B1. Can be caused by excessive chattering. See No. 1. to remedy chatter. B2. Can be caused by corrosive action. Consider alternate diaphragm material. B3. For composition diaphragms, ensure not subjecting to over-temperature conditions. B4. Downstream (outlet) pressure buildup occurring that overstresses diaphragms. Relocate regulator or protect with safety relief valve.

3. Regulator can't pass sufficient flow.

Possible Causes	Remedies
A. Regulator undersized.	A1. Confirm by opening bypass valve together with regulator. A2. Check actual flow conditions, re-size regulator; if regulator has inadequate capacity, replace with larger unit.
B. Plugged trim.	B. Remove regulator from line and check for debris in inlet connection.
C. Incorrect range spring (screwing in CW of adjusting screw does not allow bringing pressure level up to proper level).	C. Replace range spring with proper higher range.
D. Too much droop.	D1. Review droop expected. D2. Contact factory.
E. Cavitation	E. Use multiple 1465's in series to stage the pressure drops. Refer to 1465 Technical Bulletin for water cavitation chart.

4. Excessive pressure downstream.

Possible Causes	Remedies
A. Regulator not closing tightly.	A. Inspect the seating. Check that plug (3), plug spring (4), and spring seat(5) are centered in body (1) cavity. Replace regulator should these steps not remedy.
B. Downstream block.	B. Check system; isolate (block) flow at regulator inlet - not outlet. Relocate regulator if necessary.
C. No pressure relief protection.	C. Install safety relief valve, or rupture disc.
D. Restricted diaphragm movement.	D. Ensure no moisture in spring chamber at temperatures below freeze point. Ensure no dust or debris entering vent opening. If rainwater or debris can enter, re-orient regulator.

5. Sluggish operation.

Possible Causes	Remedies
A. Fluid too viscous.	A. Heat fluid. Contact factory.

6. Excessive seat leakage.

Possible Causes	Remedies
A. Foreign matter on seating surface, erosion of seating surface.	A. Inspect and clean seat. If seat eroded, replace regulator.
B. Cavitation	B. Use multiple 1465's in series to stage pressure drops. Refer to 1465 Technical Bulletin for water cavitation chart.

7. Leakage out of threaded connection between body and spring chamber.

Possible Causes	Remedies
A. Insufficient spring chamber torque.	A. Tighten spring chamber on body using sufficient torque.
B. Damaged o-ring	B. Replace o-ring.

SECTION VIII

VIII. PARTS ORDERING INFORMATION

There are three methods to obtain parts ordering information/numbers. These methods are listed below, in order of ease of entering. The least expensive method is to utilize parts in kits where possible.

METHOD A - USE OF PRODUCT CODE.

Step 1. If available, obtain the 18 character product code number from:

- a. The Bill of Materials sheet attached herein.
- b. The metal tag attached to the regulator.

□□□-□□□7-□□□□□□□□□□

Note: Some regulators may not have the product code located on the metal tag.

Step 2. Identify the kit or parts desired from the following:

- a. The Bill of Materials sheet attached herein or refer to the cross-sectional drawings.
- b. Standard maintenance parts for a basic regulator (no options) are included in the following Parts Kit Number table. Kit "A" contains diaphragm(s) plus o-rings. **NOTE:** Replace regulator should trim replacement be necessary.

Step 3. Contact your local Cashco, Inc. Sales Representative and specify the product code number, Kit "A" designation/number, and any part numbers not included in Kit "A". Costs of required parts can be given by the Sales Representative.

METHOD B - NO PRODUCT CODE AVAILABLE - DISASSEMBLED REGULATOR.

Step 1. Determine all available information from regulator's metal tag.

- a. Serial number.
- b. Regulator "Type" or "Model" number.
- c. Size (may have to observe body tap).
- d. Spring range.
- e. Trim designation number (if available).

Step 2. Determine construction of trim:

- a. Metal or composition (soft) diaphragm?

Step 3. With the information from Steps 1 and 2 above, contact your local Cashco, Inc. Sales Representative for the proper identification numbers to use, and the parts costs.

METHOD C - NO PRODUCT CODE AVAILABLE - ASSEMBLED REGULATOR IN-SERVICE.

Step 1. Determine all available information from metal tag using Step 1, Method B.

Step 2. Contact your local Cashco, Inc. Sales Rep with the above information.

Step 3. Sales Representative will contact the factory to determine the original internal construction. Factory will relay information to the Sales Representative.

Step 4. Await the Sales Representative's return contact with the proper part numbers and cost.

MODEL 1465 PARTS KIT NUMBERS (KIT NO. SHADED)

The shaded parts kit number below represents an abbreviated identification number for a basic regulator (no options).

Trim Desig. No.	Kit Abbr.	Size
		1/4" (DN8)
S1	A	4B2-AS1K-A

**MODEL 1465
COLOR-CODED SPRING CHART ***

Steel Plated Spring		
Size	Range Spring psig	Part Number/Color
1/4"	5-30	830-69-5-01350-95 (Green)
	10-80	830-69-5-01351-95 (Dark Green)
	70-140	830-69-5-01352-95 (Brown)
	125-200	830-H2-5-01353-95 (Navy)
	180-300	830-M5-5-01354-95 (Maroon)
	270-400	830-69-5-01361-95 (Turquoise)
	360-500	830-69-5-01362-95 (Purple)

** NOTE: If it becomes necessary to change a regulator's range spring and install a new spring for a different pressure range, A NEW CASHCO, INC., NAMEPLATE MUST BE AFFIXED TO THE REGULATOR. Contact your local Cashco, Inc., Sales Representative and specify the new pressure range and the serial number off the existing nameplate. They will contact the factory who will review unit's original internal construction and determine new operating pressure limits. Await the Sales Representative's return contact with proper part numbers.*

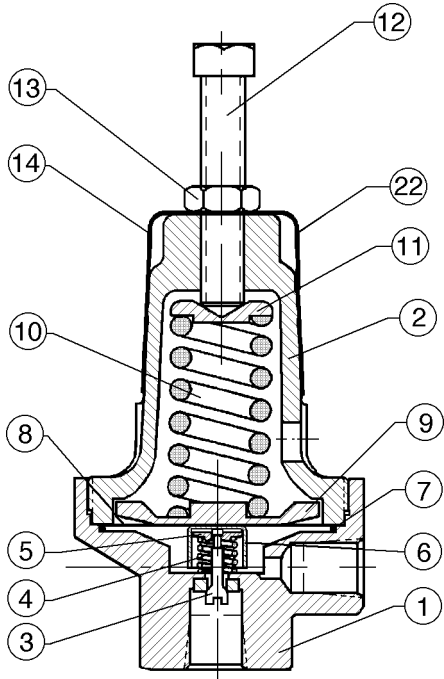
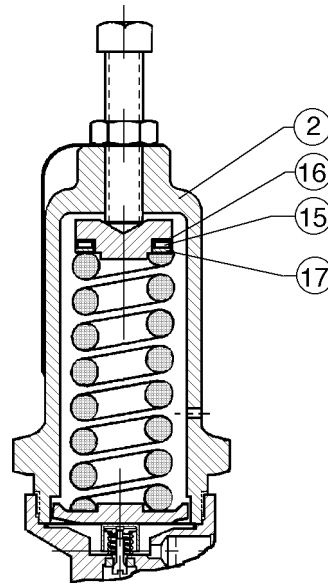
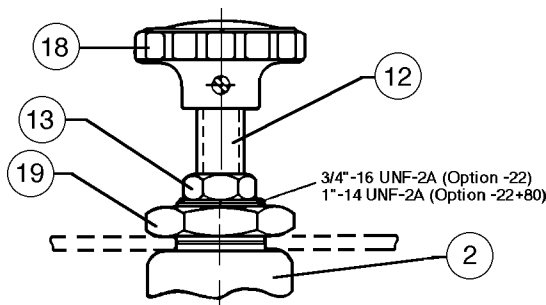

Figure 1: Basic Model 1465



**Option -80, High Pressure
Spring Chamber Construction**



**Option -22 Panel Mounting
(handwheel portion is same for
Option -2 Handwheel)**

<u>Item Number</u>	<u>Description</u>
1	Body Subassembly
2	Spring Chamber
3	Plug
4	Spring
5	Spring Seat
6	Pusher Plate
7	O-ring
8	Diaphragm
9	Pressure Plate
10	Range Spring
11	Spring Button
12	Adjusting Screw
13	Adjusting Screw Lock Nut
14	Name Plate
15	Thrust Bearing
16	Upper Bearing Washer
17	Lower Bearing Washer
18	Knob
19	Mounting Nut
22	Warning Plate

ITEM NUMBERS NOT SHOWN

20	Handwheel Subassembly
21	Pin

Cashco, Inc.
P.O. Box 6
Ellsworth, KS 67439-0006
PH (785) 472-4461
Fax (785) 472-3539
E-mail: sales@cashco.com
exportsales@cashco.com
Printed in U.S.A. IOM-1465 -sv